



## **Cisco 10008 Router Hardware Installation Guide**

June 2006

### **Americas Headquarters**

Cisco Systems, Inc.  
170 West Tasman Drive  
San Jose, CA 95134-1706  
USA  
<http://www.cisco.com>  
Tel: 408 526-4000  
800 553-NETS (6387)  
Fax: 408 527-0883

Text Part Number: OL-0659-13

THE SPECIFICATIONS AND INFORMATION REGARDING THE PRODUCTS IN THIS MANUAL ARE SUBJECT TO CHANGE WITHOUT NOTICE. ALL STATEMENTS, INFORMATION, AND RECOMMENDATIONS IN THIS MANUAL ARE BELIEVED TO BE ACCURATE BUT ARE PRESENTED WITHOUT WARRANTY OF ANY KIND, EXPRESS OR IMPLIED. USERS MUST TAKE FULL RESPONSIBILITY FOR THEIR APPLICATION OF ANY PRODUCTS.

THE SOFTWARE LICENSE AND LIMITED WARRANTY FOR THE ACCOMPANYING PRODUCT ARE SET FORTH IN THE INFORMATION PACKET THAT SHIPPED WITH THE PRODUCT AND ARE INCORPORATED HEREIN BY THIS REFERENCE. IF YOU ARE UNABLE TO LOCATE THE SOFTWARE LICENSE OR LIMITED WARRANTY, CONTACT YOUR CISCO REPRESENTATIVE FOR A COPY.

The equipment described in this manual generates and may radiate radio-frequency energy. If it is not installed in accordance with Cisco's installation instructions, it may cause interference with radio and television reception. This equipment has been tested and found to comply with the limits for a Class B digital device in accordance with the specifications in part 15 of the FCC rules. These specifications are designed to provide reasonable protection against such interference in a residential installation. However, there is no guarantee that interference will not occur in a particular installation.

Modifying the equipment without Cisco's written authorization may result in the equipment no longer complying with FCC requirements for Class A or Class B digital devices. In that event, your right to use the equipment may be limited by FCC regulations, and you may be required to correct any interference to radio or television communications at your own expense.

You can determine whether your equipment is causing interference by turning it off. If the interference stops, it was probably caused by the Cisco equipment or one of its peripheral devices. If the equipment causes interference to radio or television reception, try to correct the interference by using one or more of the following measures:

- Turn the television or radio antenna until the interference stops.
- Move the equipment to one side or the other of the television or radio.
- Move the equipment farther away from the television or radio.
- Plug the equipment into an outlet that is on a different circuit from the television or radio. (That is, make certain the equipment and the television or radio are on circuits controlled by different circuit breakers or fuses.)

Modifications to this product not authorized by Cisco Systems, Inc. could void the FCC approval and negate your authority to operate the product.

The Cisco implementation of TCP header compression is an adaptation of a program developed by the University of California, Berkeley (UCB) as part of UCB's public domain version of the UNIX operating system. All rights reserved. Copyright © 1981, Regents of the University of California.

NOTWITHSTANDING ANY OTHER WARRANTY HEREIN, ALL DOCUMENT FILES AND SOFTWARE OF THESE SUPPLIERS ARE PROVIDED "AS IS" WITH ALL FAULTS. CISCO AND THE ABOVE-NAMED SUPPLIERS DISCLAIM ALL WARRANTIES, EXPRESSED OR IMPLIED, INCLUDING, WITHOUT LIMITATION, THOSE OF MERCHANTABILITY, FITNESS FOR A PARTICULAR PURPOSE AND NONINFRINGEMENT OR ARISING FROM A COURSE OF DEALING, USAGE, OR TRADE PRACTICE.

IN NO EVENT SHALL CISCO OR ITS SUPPLIERS BE LIABLE FOR ANY INDIRECT, SPECIAL, CONSEQUENTIAL, OR INCIDENTAL DAMAGES, INCLUDING, WITHOUT LIMITATION, LOST PROFITS OR LOSS OR DAMAGE TO DATA ARISING OUT OF THE USE OR INABILITY TO USE THIS MANUAL, EVEN IF CISCO OR ITS SUPPLIERS HAVE BEEN ADVISED OF THE POSSIBILITY OF SUCH DAMAGES.

CCVP, the Cisco Logo, and the Cisco Square Bridge logo are trademarks of Cisco Systems, Inc.; Changing the Way We Work, Live, Play, and Learn is a service mark of Cisco Systems, Inc.; and Access Registrar, Aironet, BPX, Catalyst, CCDA, CCDP, CCIE, CCIP, CCNA, CCNP, CCSP, Cisco, the Cisco Certified Internetwork Expert logo, Cisco IOS, Cisco Press, Cisco Systems, Cisco Systems Capital, the Cisco Systems logo, Cisco Unity, Enterprise/Solver, EtherChannel, EtherFast, EtherSwitch, Fast Step, Follow Me Browsing, FormShare, GigaDrive, GigaStack, HomeLink, Internet Quotient, IOS, iPhone, IP/TV, iQ Expertise, the iQ logo, iQ Net Readiness Scorecard, iQuick Study, LightStream, Linksys, MeetingPlace, MGX, Networking Academy, Network Registrar, Packet, PIX, ProConnect, RateMUX, ScriptShare, SlideCast, SMARTnet, StackWise, The Fastest Way to Increase Your Internet Quotient, and TransPath are registered trademarks of Cisco Systems, Inc. and/or its affiliates in the United States and certain other countries.

All other trademarks mentioned in this document or Website are the property of their respective owners. The use of the word partner does not imply a partnership relationship between Cisco and any other company. (0612R)



# CONTENTS

<b>Preface</b>	<b>vii</b>	
Document Version History	vii	
Audience	viii	
Purpose	viii	
Document Organization	viii	
Document Conventions	viii	
Notes and Cautions	ix	
Safety Warnings	ix	
Related Documentation	xi	
Obtaining Documentation	xi	
Cisco.com	xi	
Ordering Documentation	xii	
Documentation Feedback	xii	
Obtaining Technical Assistance	xii	
Cisco Technical Support Website	xii	
Submitting a Service Request	xiii	
Definitions of Service Request Severity	xiii	
Obtaining Additional Publications and Information	xiv	
<b>CHAPTER 1</b>	<b>Cisco 10008 Router Overview</b>	<b>1-1</b>
	Cisco 10008 Router Features	1-2
	Cisco 10008 Router Software	1-3
	Minimum Software Releases for the Cisco 10008 Router	1-3
	Cisco 10008 Router Hardware Description	1-3
	Blower Module	1-6
	Power Entry Modules	1-6
	Line Card and PRE Module Compartment	1-8
	Performance Routing Engine	1-8
	Connector Ports	1-9
	PCMCIA Card Slots	1-10
	PRE LED Indicators and Switches	1-10
	Alphanumeric Display	1-11

Disposing of the PRE 1-11

**CHAPTER 2**

**Preparing for Installation 2-1**

- Site Planning 2-1
  - Cisco Professional Installation 2-2
  - Site Selection Guidelines 2-2
    - Site Environmental Requirements 2-2
    - Heat Dissipation 2-2
    - Physical Characteristics 2-3
  - Floor Loading Considerations 2-3
  - Site Power Requirements 2-3
    - Electrical Service Requirements 2-4
    - Electrical Circuit Requirements 2-4
  - Site Cabling Guidelines 2-5
    - Interference Considerations 2-6
    - Asynchronous Terminal Connections 2-6
    - Ethernet Connections 2-6
    - Setting Up Fiber-Optic Connections 2-7
    - Interference Considerations 2-7
  - Rack-Mounting and Location Guidelines 2-8
    - Rack Selection Guidelines 2-8
    - Rack Configuration Guidelines 2-8
    - Rack Placement Guidelines 2-9
  - Site Planning Checklist 2-11
- Safety 2-11
  - Preventing Electrostatic Discharge Damage 2-12
  - Electrical Safety 2-13
    - Receiving the Cisco 10000 Series Router 2-14
  - Chassis-Lifting Guidelines 2-15
  - Required Tools and Equipment 2-16
    - Verifying Contents After Unpacking 2-16

**CHAPTER 3**

**Installing the Cisco 10008 Router 3-1**

- Installation Methods 3-1
- Rack-Mounting the Chassis 3-2
  - General Rack Installation Guidelines 3-2
  - Flush-Mounting in a 19-Inch Rack 3-3
  - Center-Mounting in a 19-Inch Rack 3-5
  - Center-Mounting in a 23-Inch Rack 3-7

Non-Rack Installation	3-11
Connecting the Chassis to Ground	3-13
Recommended Tools and Supplies	3-14
Attaching the Grounding Cable	3-14
Connecting DC Power to the Cisco 10008 Router	3-17
Recommended Tools and Supplies	3-18
Connecting AC Power to the Cisco 10008 Router	3-22
Connecting Alarm Indicators	3-26
Connecting a Video Terminal to the PRE Console Port	3-30
Connecting Network Management and Signal System Cables	3-32
Ethernet Network Management Cable Connections	3-32
Connecting to a 10BASE-T Ethernet Network	3-32
Connecting to a 100BASE-T Ethernet Network	3-33
Auxiliary Modem Connection	3-35
Data Network Cable Connections	3-35

**CHAPTER 4**

<b>Starting and Configuring the Router</b>	<b>4-1</b>
Powering On the System	4-1
Configuring the Cisco 10008 Router at Startup	4-2
Startup Display	4-3
Basic Configuration Using the Setup Facility	4-3
Using the System Configuration Dialog	4-4
Basic System Configuration Procedure	4-4
Basic Configuration in Global Configuration Mode	4-6
Formatting Flash Memory Cards and Disks	4-6
Managing the File Systems	4-7
File Systems	4-7
Copying the Startup Configuration to the Running Configuration	4-8
Managing Configuration Files Larger than NVRAM	4-8
Compressing the Configuration File	4-8
Relocating the Configuration to a Flash Disk	4-9
Managing System Boot Parameters	4-9
Changing the Configuration Register Settings	4-10
Configuration Register Settings	4-10
Predeployment Testing	4-11
Troubleshooting Installation Problems	4-12
General Troubleshooting Tips	4-12
Troubleshooting Ethernet Connections	4-13

Troubleshooting the Console Port Serial Connection 4-14

---

**CHAPTER 5**

**Maintaining the Cisco 10008 Router 5-1**

- Required Maintenance Tools 5-3
- Shutting Down the System 5-3
- Backing Up the PCMCIA Card 5-3
- Removing and Replacing Field-Replaceable Units 5-3
  - Front Cover Procedures 5-4
    - Removing the Front Cover 5-4
    - Replacing the Front Cover 5-6
  - Replacing the Air Filter 5-7
    - Replacing an Air Filter in a Chassis that Uses a Filter Tray 5-7
    - Replacing an Air Filter in a Chassis with Release Tabs 5-9
  - Replacing the Blower Module 5-10
  - Installing Power Entry Modules 5-12
    - Installing a Second DC PEM 5-12
    - Replacing a DC PEM 5-20
    - Installing a Second AC PEM 5-24
    - Replacing an AC PEM 5-28
  - Connecting Alarm Indicators 5-32
    - Removing and Replacing the PRE 5-36
      - Removing and Installing a PCMCIA Flash Memory Card 5-44
  - Upgrading SDRAM on the PRE 5-46
    - Removing and Installing DIMMS 5-47
    - Troubleshooting the DIMM Installation 5-49

---

**APPENDIX A**

**Technical Specifications A-1**

---

**APPENDIX B**

**Repacking the Box B-1**

---

**GLOSSARY**

---

**INDEX**



## Preface

---

This preface describes the audience, purpose, organization, and conventions used in the *Cisco 10008 Router Hardware Installation Guide*. There is also a list of related documents and instructions for obtaining technical assistance and additional information.

## Document Version History

This is the first version of this document with an online part number. The document version history beginning with this online part number is in Table 1.

**Table 1**      **Document Version History**

Document Version	Date	Notes
OL-0659-11	July, 2005	<p>This version contains site planning and preparation information previously found in the <i>Technology of Edge Aggregation</i> document. This version also contains configuration register information, flash disk formatting information, and other similar information previously found in the <i>Cisco 10000 Series Router Line Card Configuration Guide</i>.</p> <p>Line card hardware information has moved to the new <i>Cisco 10000 Series Routers Line Card Hardware Installation Guide</i>. Regulatory compliance and safety information has moved to the new <i>Regulatory Compliance and Safety Information for the Cisco 10000 Series Routers</i>.</p>
OL-0659-12	December, 2005	<p>This version updates table 3-1 for 6AWG cable dimensions. Revises the part number and copyright.</p>
OL-0659-13	June, 2006	<p>This version includes revised procedural information in the <a href="#">“Replacing the Air Filter”</a> section.</p>

# Audience

To use this guide, you should be familiar not only with Cisco router hardware and cabling, but also with electronic circuitry and wiring practices. You should be able to perform basic network configuration procedures, and preferably have experience as an electronic or electromechanical technician.

# Purpose

This installation guide explains the initial hardware installation and basic configuration procedures for the Cisco 10008 router. It contains procedures for installing the router hardware, creating a basic software configuration file, and starting up the router. After you complete the installation and basic configuration procedures covered in this guide, use the appropriate companion publications to more completely configure your system. Refer to the documents listed in the [“Related Documentation” section on page xi](#).

# Document Organization

This publication is organized as follows:

- [Chapter 1, “Cisco 10008 Router Overview,”](#) describes the physical properties of the Cisco 10008 router components and a functional overview of the system.
- [Chapter 2, “Preparing for Installation,”](#) is a preparatory chapter that describes site preparation and requirements, safety considerations, tools required, and procedures you should perform *before* the installation.
- [Chapter 3, “Installing the Cisco 10008 Router,”](#) provides information for installing the router hardware, connecting system cables, and verifying system operation.
- [Chapter 4, “Starting and Configuring the Router,”](#) provides information for starting and configuring the router, formatting a flash disk and flash memory card, and information for verifying the installation.
- [Chapter 5, “Maintaining the Cisco 10008 Router,”](#) describes the procedures required to perform routine maintenance and to remove and replace field replaceable units (FRUs) in the Cisco 10008 router.
- [Appendix A, “Technical Specifications,”](#) contains the electrical and physical specifications for the Cisco 10008 router.
- [Appendix B, “Repacking the Box,”](#) describes how to repack your system for shipping.
- [“Glossary,”](#) describes terms and acronyms associated with the Cisco 10008 router.
- [“Index”](#)

# Document Conventions

Command descriptions use these conventions:

- Examples that contain system prompts denote interactive sessions, indicating the commands that you should enter at the prompt. The system prompt indicates the current level of the EXEC command interpreter.



For example, the prompt `router>` indicates that you should be at the *user* level, and the prompt `router#` indicates that you should be at the *privileged* level. Access to the privileged level usually requires a password. Refer to the related software configuration and reference documentation for additional information.

- Commands and key names words are in **bold** text.
- Arguments for which you supply values are in *italic* text.
- Optional elements appear in square brackets [ ].
- Alternative but required keywords are grouped in braces { } and separated by vertical bars |.

Examples use these conventions:

- Terminal sessions and sample console window displays are in `screen` font.
- Information you enter is in **bold screen** font.
- Nonprinting characters, such as passwords, are in angle brackets < >.
- Default responses to system prompts are in square brackets [ ].
- Exclamation points (!) at the beginning of a line indicate a comment line.

## Notes and Cautions

Notes and Cautions contain important information that you should be aware of.



### Note

---

Means *reader take note*. Notes contain helpful suggestions or references to materials not contained in this publication.

---



### Caution

---

Means *reader be careful*. You are capable of doing something that might result in equipment damage or loss of data.

---

## Safety Warnings

Safety warnings appear throughout this publication in procedures that, if performed incorrectly, may harm you. A warning symbol precedes each warning statement.



### Note

---

See the [Regulatory Compliance and Safety Information for the Cisco 10000 Series Routers](#) for a listing of translated safety warnings.

---

**Warning**

Means danger. You are in a situation that could cause bodily injury. Before you work on any equipment, be aware of the hazards involved with electrical circuitry and be familiar with standard practices for preventing accidents. To see translations of the warnings that appear in this publication, refer to the *Regulatory Compliance and Safety Information* document that accompanied this device. Statement 1071

**Waarschuwing**

Dit waarschuwingssymbool betekent gevaar. U verkeert in een situatie die lichamelijk letsel kan veroorzaken. Voordat u aan enige apparatuur gaat werken, dient u zich bewust te zijn van de bij elektrische schakelingen betrokken risico's en dient u op de hoogte te zijn van standaard maatregelen om ongelukken te voorkomen. Voor vertalingen van de waarschuwingen die in deze publicatie verschijnen, kunt u het document *Regulatory Compliance and Safety Information* (Informatie over naleving van veiligheids- en andere voorschriften) raadplegen dat bij dit toestel is ingesloten.

**Varoitus**

Tämä varoitusmerkki merkitsee vaaraa. Olet tilanteessa, joka voi johtaa ruumiinvammaan. Ennen kuin työskentelet minkään laitteiston parissa, ota selvää sähkökytkentöihin liittyvistä vaaroista ja tavanomaisista onnettomuuksien ehkäisykeinoista. Tässä julkaisussa esiintyvien varoitusten käännökset löydät laitteen mukana olevasta *Regulatory Compliance and Safety Information* -kirjasesta (määräysten noudattaminen ja tietoa turvallisuudesta).

**Attention**

Ce symbole d'avertissement indique un danger. Vous vous trouvez dans une situation pouvant causer des blessures ou des dommages corporels. Avant de travailler sur un équipement, soyez conscient des dangers posés par les circuits électriques et familiarisez-vous avec les procédures couramment utilisées pour éviter les accidents. Pour prendre connaissance des traductions d'avertissements figurant dans cette publication, consultez le document *Regulatory Compliance and Safety Information* (Conformité aux règlements et consignes de sécurité) qui accompagne cet appareil.

**Warnung**

Dieses Warnsymbol bedeutet Gefahr. Sie befinden sich in einer Situation, die zu einer Körperverletzung führen könnte. Bevor Sie mit der Arbeit an irgendeinem Gerät beginnen, seien Sie sich der mit elektrischen Stromkreisen verbundenen Gefahren und der Standardpraktiken zur Vermeidung von Unfällen bewusst. Übersetzungen der in dieser Veröffentlichung enthaltenen Warnhinweise finden Sie im Dokument *Regulatory Compliance and Safety Information* (Informationen zu behördlichen Vorschriften und Sicherheit), das zusammen mit diesem Gerät geliefert wurde.

**Avvertenza**

Questo simbolo di avvertenza indica un pericolo. La situazione potrebbe causare infortuni alle persone. Prima di lavorare su qualsiasi apparecchiatura, occorre conoscere i pericoli relativi ai circuiti elettrici ed essere al corrente delle pratiche standard per la prevenzione di incidenti. La traduzione delle avvertenze riportate in questa pubblicazione si trova nel documento *Regulatory Compliance and Safety Information* (Conformità alle norme e informazioni sulla sicurezza) che accompagna questo dispositivo.

**Advarsel**

Dette varselsymbolet betyr fare. Du befinner deg i en situasjon som kan føre til personskade. Før du utfører arbeid på utstyr, må du være oppmerksom på de faremomentene som elektriske kretser innebærer, samt gjøre deg kjent med vanlig praksis når det gjelder å unngå ulykker. Hvis du vil se oversettelser av de advarslene som finnes i denne publikasjonen, kan du se i dokumentet *Regulatory Compliance and Safety Information* (Overholdelse av forskrifter og sikkerhetsinformasjon) som ble levert med denne enheten.

- Aviso** Este símbolo de aviso indica perigo. Encontra-se numa situação que lhe poderá causar danos físicos. Antes de começar a trabalhar com qualquer equipamento, familiarize-se com os perigos relacionados com circuitos eléctricos, e com quaisquer práticas comuns que possam prevenir possíveis acidentes. Para ver as traduções dos avisos que constam desta publicação, consulte o documento *Regulatory Compliance and Safety Information* (Informação de Segurança e Disposições Reguladoras) que acompanha este dispositivo.
- ¡Advertencia!** Este símbolo de aviso significa peligro. Existe riesgo para su integridad física. Antes de manipular cualquier equipo, considerar los riesgos que entraña la corriente eléctrica y familiarizarse con los procedimientos estándar de prevención de accidentes. Para ver una traducción de las advertencias que aparecen en esta publicación, consultar el documento titulado *Regulatory Compliance and Safety Information* (Información sobre seguridad y conformidad con las disposiciones reglamentarias) que se acompaña con este dispositivo.
- Varning!** Denna varningssymbol signalerar fara. Du befinner dig i en situation som kan leda till personskada. Innan du utför arbete på någon utrustning måste du vara medveten om farorna med elkretsar och känna till vanligt förfarande för att förebygga skador. Se förklaringar av de varningar som förkommer i denna publikation i dokumentet *Regulatory Compliance and Safety Information* (Efterrättelse av föreskrifter och säkerhetsinformation), vilket medföljer denna anordning.
- 

## Related Documentation

See the [Cisco 10000 Series Routers Documentation Roadmap](#) for a complete listing of all the documentation related to the Cisco 10008 router.

See the [Regulatory Compliance and Safety Information for the Cisco 10000 Series Routers](#) for all translated safety warnings and regulatory and compliance information.

## Obtaining Documentation

Cisco documentation and additional literature are available on Cisco.com. Cisco also provides several ways to obtain technical assistance and other technical resources. These sections explain how to obtain technical information from Cisco Systems.

### Cisco.com

You can access the most current Cisco documentation at this URL:

<http://www.cisco.com/univercd/home/home.htm>

You can access the Cisco website at this URL:

<http://www.cisco.com>

You can access international Cisco websites at this URL:

[http://www.cisco.com/public/countries\\_languages.shtml](http://www.cisco.com/public/countries_languages.shtml)

## Ordering Documentation

You can find instructions for ordering documentation at this URL:

[http://www.cisco.com/univercd/cc/td/doc/es\\_inpk/pdi.htm](http://www.cisco.com/univercd/cc/td/doc/es_inpk/pdi.htm)

You can order Cisco documentation in these ways:

- Registered Cisco.com users (Cisco direct customers) can order Cisco product documentation from the Ordering tool:

<http://www.cisco.com/en/US/partner/ordering/index.shtml>

- Nonregistered Cisco.com users can order documentation through a local account representative by calling Cisco Systems Corporate Headquarters (California, USA) at 408 526-7208 or, elsewhere in North America, by calling 1 800 553-NETS (6387).

## Documentation Feedback

You can send comments about technical documentation to [bug-doc@cisco.com](mailto:bug-doc@cisco.com).

You can submit comments by using the response card (if present) behind the front cover of your document or by writing to the following address:

Cisco Systems  
Attn: Customer Document Ordering  
170 West Tasman Drive  
San Jose, CA 95134-9883

We appreciate your comments.

## Obtaining Technical Assistance

For all customers, partners, resellers, and distributors who hold valid Cisco service contracts, Cisco Technical Support provides 24-hour-a-day, award-winning technical assistance. The Cisco Technical Support Website on Cisco.com features extensive online support resources. In addition, Cisco Technical Assistance Center (TAC) engineers provide telephone support. If you do not hold a valid Cisco service contract, contact your reseller.

## Cisco Technical Support Website

The Cisco Technical Support Website provides online documents and tools for troubleshooting and resolving technical issues with Cisco products and technologies. The website is available 24 hours a day, 365 days a year, at this URL:

<http://www.cisco.com/techsupport>

Access to all tools on the Cisco Technical Support Website requires a Cisco.com user ID and password. If you have a valid service contract but do not have a user ID or password, you can register at this URL:

<http://tools.cisco.com/RPF/register/register.do>

**Note**

Use the Cisco Product Identification (CPI) tool to locate your product serial number before submitting a web or phone request for service. You can access the CPI tool from the Cisco Technical Support Website by clicking the **Tools & Resources** link under Documentation & Tools. Choose **Cisco Product Identification Tool** from the Alphabetical Index drop-down list, or click the **Cisco Product Identification Tool** link under Alerts & RMAs. The CPI tool offers three search options: by product ID or model name; by tree view; or for certain products, by copying and pasting **show** command output. Search results show an illustration of your product with the serial number label location highlighted. Locate the serial number label on your product and record the information before placing a service call.

## Submitting a Service Request

Using the online TAC Service Request Tool is the fastest way to open S3 and S4 service requests. (S3 and S4 service requests are those in which your network is minimally impaired or for which you require product information.) After you describe your situation, the TAC Service Request Tool provides recommended solutions. If your issue is not resolved using the recommended resources, your service request is assigned to a Cisco TAC engineer. The TAC Service Request Tool is located at this URL:

<http://www.cisco.com/techsupport/servicerequest>

For S1 or S2 service requests or if you do not have Internet access, contact the Cisco TAC by telephone. (S1 or S2 service requests are those in which your production network is down or severely degraded.) Cisco TAC engineers are assigned immediately to S1 and S2 service requests to help keep your business operations running smoothly.

To open a service request by telephone, use one of the following numbers:

Asia-Pacific: +61 2 8446 7411 (Australia: 1 800 805 227)

EMEA: +32 2 704 55 55

USA: 1 800 553-2447

For a complete list of Cisco TAC contacts, go to this URL:

<http://www.cisco.com/techsupport/contacts>

## Definitions of Service Request Severity

To ensure that all service requests are reported in a standard format, Cisco has established severity definitions.

**Severity 1 (S1)**—Your network is “down,” or there is a critical impact to your business operations. You and Cisco will commit all necessary resources around the clock to resolve the situation.

**Severity 2 (S2)**—Operation of an existing network is severely degraded, or significant aspects of your business operation are negatively affected by inadequate performance of Cisco products. You and Cisco will commit full-time resources during normal business hours to resolve the situation.

**Severity 3 (S3)**—Operational performance of your network is impaired, but most business operations remain functional. You and Cisco will commit resources during normal business hours to restore service to satisfactory levels.

**Severity 4 (S4)**—You require information or assistance with Cisco product capabilities, installation, or configuration. There is little or no effect on your business operations.

# Obtaining Additional Publications and Information

Information about Cisco products, technologies, and network solutions is available from various online and printed sources.

- Cisco Marketplace provides a variety of Cisco books, reference guides, and logo merchandise. Visit Cisco Marketplace, the company store, at this URL:

<http://www.cisco.com/go/marketplace/>

- The Cisco *Product Catalog* describes the networking products offered by Cisco Systems, as well as ordering and customer support services. Access the Cisco Product Catalog at this URL:

<http://cisco.com/univercd/cc/td/doc/pcat/>

- *Cisco Press* publishes a wide range of general networking, training and certification titles. Both new and experienced users will benefit from these publications. For current Cisco Press titles and other information, go to Cisco Press at this URL:

<http://www.ciscopress.com>

- *Packet* magazine is the Cisco Systems technical user magazine for maximizing Internet and networking investments. Each quarter, Packet delivers coverage of the latest industry trends, technology breakthroughs, and Cisco products and solutions, as well as network deployment and troubleshooting tips, configuration examples, customer case studies, certification and training information, and links to scores of in-depth online resources. You can access Packet magazine at this URL:

<http://www.cisco.com/packet>

- *iQ Magazine* is the quarterly publication from Cisco Systems designed to help growing companies learn how they can use technology to increase revenue, streamline their business, and expand services. The publication identifies the challenges facing these companies and the technologies to help solve them, using real-world case studies and business strategies to help readers make sound technology investment decisions. You can access iQ Magazine at this URL:

<http://www.cisco.com/go/iqmagazine>

- *Internet Protocol Journal* is a quarterly journal published by Cisco Systems for engineering professionals involved in designing, developing, and operating public and private internets and intranets. You can access the Internet Protocol Journal at this URL:

<http://www.cisco.com/ipj>

- World-class networking training is available from Cisco. You can view current offerings at this URL:

<http://www.cisco.com/en/US/learning/index.html>



# CHAPTER 1

## Cisco 10008 Router Overview

---

The Cisco 10008 router is a high capacity Layer 3 router optimized to support selected Cisco IOS software services at wire speed performance on thousands of DS1/T1 connections. Designed primarily for use in a telco central office environment, it provides interfaces that connect to large numbers of subscribers using low-speed circuits, and then funnels all of that subscriber traffic into a small number of high-speed trunk interfaces. The chassis has eight line card slots and two slots for Performance Routing Engine (PRE) modules.

This chapter contains the following sections:

- [Cisco 10008 Router Features, page 1-2](#)
- [Cisco 10008 Router Software, page 1-3](#)
- [Cisco 10008 Router Hardware Description, page 1-3](#)



### Note

---

The illustrations in this guide depict the original Cisco 10008 chassis. Your chassis may look slightly different, but it is functionally the same.

---

The Cisco 10008 router is designed to meet and exceed the most stringent ISP requirements for product availability and reliability. Its features include:

- Redundant blowers
- Redundant power (AC or DC)
- Redundant PREs
- Pairs of Synchronous Optical Network (SONET) interfaces which can be configured for redundancy using SONET 1+1 Automatic Protection Switching (APS)
- All line cards, Power Entry Modules (PEMs), and blowers can be hot-swapped without powering down the chassis

Performance routing engine redundancy in the Cisco 10008 router is achieved through an implementation of Enhanced High System Availability (EHSA). This feature lets you configure the chassis for non-redundant operation with one PRE, or for redundant operation with two PREs.

In addition to PRE redundancy, SONET/SDH line cards can be configured for 1+1 Automatic Protection Switching (APS) to accommodate failure of either a line card or the transmission facility carrying trunk traffic to upstream equipment.

The Cisco 10008 router is designed to scale to unprecedented levels with plans to further increase scalability in future releases. The current release provides support for up to:

- 1300 PPP sessions
- 4200 Frame Relay sessions
- 300 Border Gateway Protocol (BGP) peers

For CT3 line cards, this equates to:

- 1176 T1 connections per chassis or up to 3900 T1 connections per 7-foot rack.

For channelized OC-12 line cards, this equates to:

- 2352 T1 connections per chassis or up to 7056 T1 connections per 7-foot rack.

## Cisco 10008 Router Features

The Cisco 10008 router and power subsystem support the following key features:

- 19-inch rack mount, 12-inch depth
- 21.75-inch height (3 units per 7-foot rack)
- Dual -48 VDC or 100 to 240 VAC redundant hot swappable PEMs
- 10 slots total, 2 central slots for PREs and 8 interface card slots
- Multiple fans in blower module provide redundancy to support single failure, and blower replacement will not interrupt service (within certain time limits)
- Brackets for cable management
- Alarm relays; minor, major, and critical



# Cisco 10008 Router Software

Software is stored on the PRE which includes two PCMCIA slots that are accessible from the front panel. Either slot can store an Cisco IOS image or configuration file.

The flash memory present on Cisco 10000 router line cards is used to store a simple ROM monitor/boot loader. The loader executes following a system reset, line card reset, or line card insertion.

Line card images may also be stored in PRE flash memory or on an external TFTP server.

The PRE stores the system configuration in a 512KB NVRAM device. Configuration information read from NVRAM is buffered in RAM following initialization, and is written to the device when you save the configuration.

## Minimum Software Releases for the Cisco 10008 Router

For a listing of the minimum software releases supported on the Cisco 10008 router, see the [Cisco 10000 Series Routers Documentation Roadmap](#), Release Notes.

## Cisco 10008 Router Hardware Description

The Cisco 10008 router is Network Equipment Building Standards (NEBS) Level 3 compliant. This includes:

- Front-to-back airflow
- 12-inch depth

Less than 22 inches in height (you can configure up to three Cisco 10008 routers per 7-foot rack).

The chassis supports redundant AC or DC power, and contains:

- 8 line card slots
- 2 processor card slots
- Backplane (with rear interconnects)
- Capacity for dual –48 VDC or 100 to 240 VAC Power Entry Modules (PEMs)

[Figure 1-1](#) shows a front view of the Cisco 10008 router. [Figure 1-2](#) shows the BNC connectors, line card slots from the rear, and half-height line card subslot designations on the rear of the router.

Figure 1-1 Cisco 10008 Router Chassis—Front View

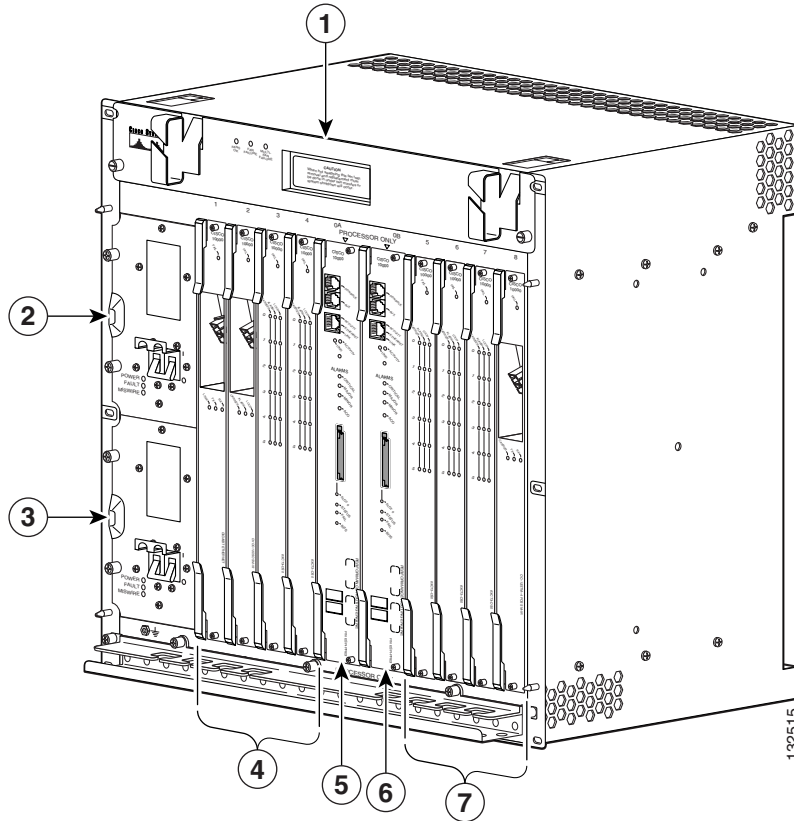

<b>1</b>	Blower module	<b>5</b>	PRE - slot 0A
<b>2</b>	Primary PEM	<b>6</b>	PRE slot 0B
<b>3</b>	Redundant PEM	<b>7</b>	Line cards slots 5 to 8
<b>4</b>	Line cards slots 1 to 4		

**Figure 1-2 BNC Connectors on the Rear of the Chassis**

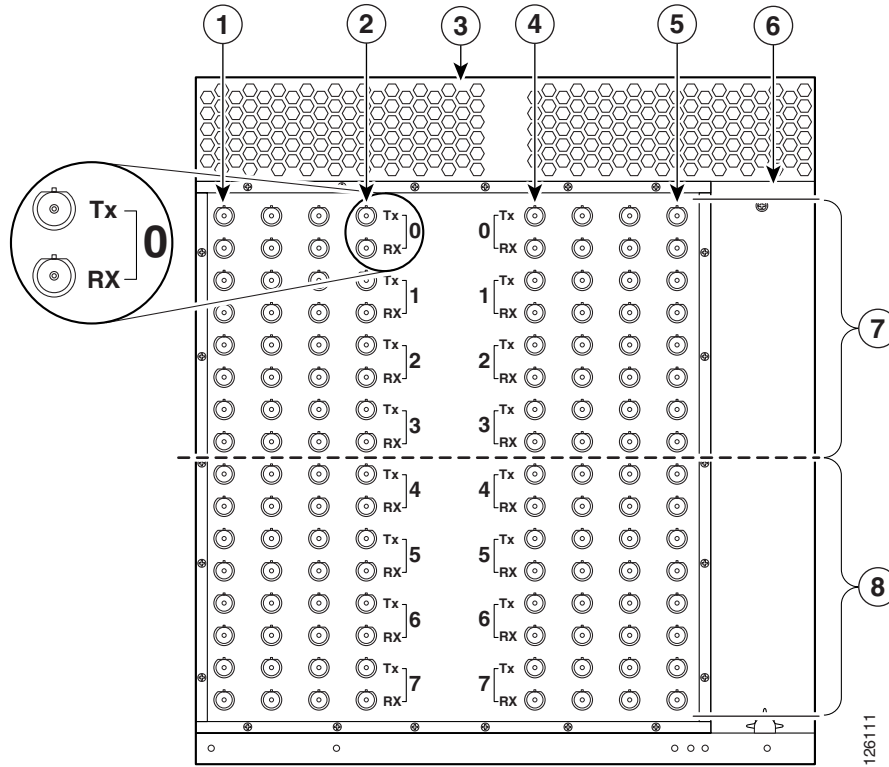

<b>1</b>	Line card slot 8	<b>5</b>	Line card slot 1
<b>2</b>	Line cards slot 5	<b>6</b>	Power supply
<b>3</b>	Blower module	<b>7</b>	Half-height line card subslot 0
<b>4</b>	Line card slot 4	<b>8</b>	Half-height line card subslot 1

The Cisco 10008 chassis is designed for mounting in 19-inch or (optional) 23-inch equipment racks, and contains the following components:

- [Blower Module, page 1-6](#)
- [Power Entry Modules, page 1-6](#)
- [Connector Ports, page 1-9](#)
- [PCMCIA Card Slots, page 1-10](#)

## Blower Module

The Cisco 10008 router uses a blower module ([Figure 1-3](#)) containing four fans to supply cooling air to the chassis.

**Figure 1-3** Blower Module

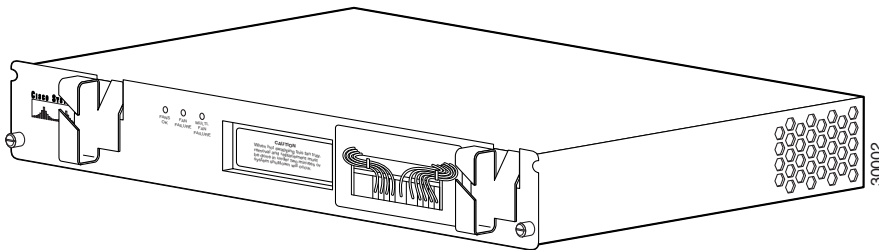

The blower module is located at the top of the chassis and connects to a connector on the chassis.

1. Four internal fans draw cooling air into the front of the chassis and direct it across the internal components to maintain an acceptable operating temperature.
2. The air is exhausted through openings in the rear of the chassis.

Although the blower module supports hot-swapping and can be replaced without interruption to system operation, do not power down the system without the blower unit for more than a few minutes to prevent overheating.

## Power Entry Modules

The DC PEM provides filtering and supplies DC power to the chassis electronics ([Figure 1-4](#)). DC PEMs receive input power (–48 VDC from building centralized power source) through terminal block connections located on the rear of the chassis.

[Table 1-1](#) describes the LEDs on the DC PEM.

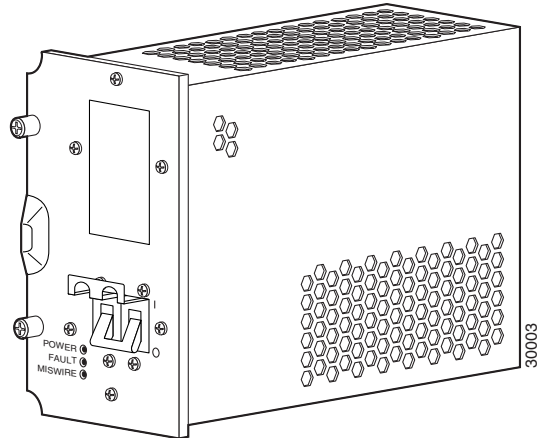
**Figure 1-4 DC PEM****Table 1-1 DC PEM LEDs**

LED	Description
Power (green)	PEM is powered on and is operational.
Fault (yellow)	The PEM is not operating correctly (see the <i>Cisco 10000 Series ESR Troubleshooting Guide</i> ).
Miswire (yellow)	–48V and RTN (+) wires are reversed (see the <a href="#">“Troubleshooting Installation Problems”</a> section on page 4-12).

The AC PEM provides power conversion directly from the facility VAC input power (100-240 VAC) to the –48 VDC used internally by the system (Figure 1-5). AC power is delivered to the AC PEM from the VAC connection power cable to the power cord attached to the PEM.

Table 1-2 describes the LEDs on the AC PEM.

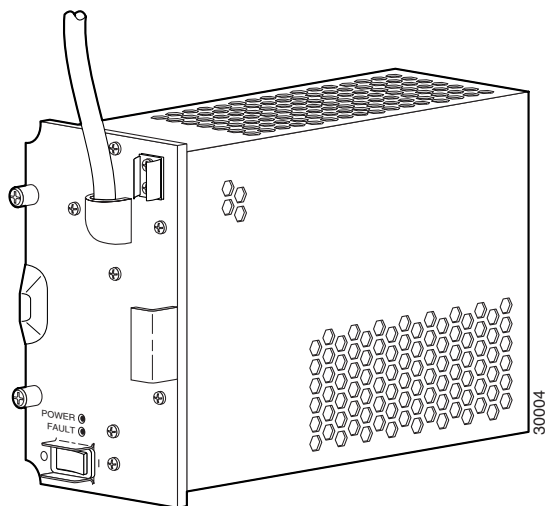
**Figure 1-5 AC PEM****Table 1-2 AC PEM LEDs**

LED	Description
Power (green)	PEM is powered on and is operational.
Fault (yellow)	The PEM is not operating correctly (see the <i>Cisco 10000 Series ESR Troubleshooting Guide</i> ).

## Line Card and PRE Module Compartment

The module compartment has 10 slots: the two central slots are reserved for PRE modules, and the remaining 8 slots accommodate full-height line cards. The PRE and line cards support hot-swapping and redundancy. See [Figure 1-1](#) for a front view of the module compartment, and [Figure 1-2](#) for a rear view of the module compartment, BNC connectors, and line card subslot designations.

For information about the line card that the Cisco 10008 router supports, see the [Cisco 10000 Routers Line Card Hardware Installation Guide](#), and for line card configuration information, see the [Cisco 10000 Series Router Line Card Configuration Guide](#).

## Performance Routing Engine

The PRE is the central router and system controller (SC) for the Cisco 10008 router. It is responsible for all Layer 2 and Layer 3 packet processing, as well as execution of routing protocols and management of the system. The PRE consists of two main logical and physical cards:

- Forwarding processor card—Performs high-speed IP forwarding
- Route processor card—Manages process switching and several protocols

The high performance forwarding engine in the PRE is Cisco's Parallel eXpress Forwarding (PXF) application specific integrated circuit (ASIC). The two PXF ASICs on the PRE direct traffic to and from the router line cards.

Each PXF ASIC has 32 independent processors that work on per-packet feature processing, yielding high throughput while still allowing substantial feature processing. The PXF centralizes packet processing in the PRE, which frees up space on line cards, enabling high interface density, yet retaining a compact form factor.



**Caution**

Although the PRE module supports hot-swapping, one PRE is required for the system to operate. Hot-swapping a non-redundant PRE results in a system outage stopping all traffic. A PRE in a redundant configuration can be hot-swapped without having an impact on system operation.

Figure 1-6 shows the front panel of the Performance Routing Engine, product number ESR- PRE.

**Figure 1-6 Performance Routing Engine, Product Number ESR-PRE, Front Panel**

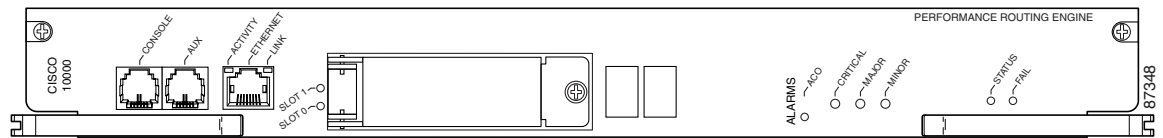

Figure 1-7 shows the front panel of the Performance Routing Engine, product number ESR-PRE1.

**Figure 1-7 Performance Routing Engine, Product Number ESR-PRE1, Front Pane**

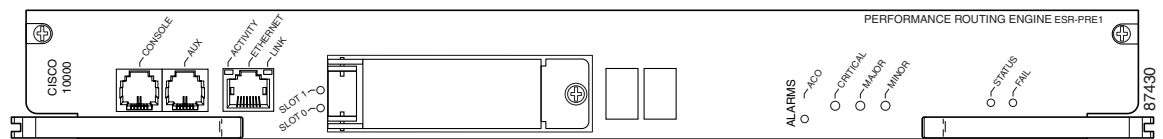
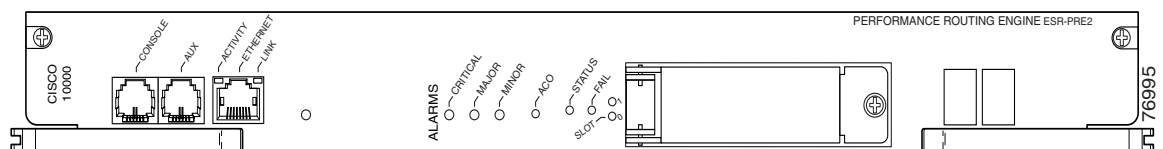

Figure 1-8 shows the front panel of the Performance Routing Engine, product number ESR-PRE2.

**Figure 1-8 Performance Routing Engine, Product Number ESR-PRE2, Front Panel**



## Connector Ports

The front panel on the PRE contains three ports with RJ-45 connectors (see Figure 1-6):

- Console port (CON)—This asynchronous EIA/TIA-232 serial port is used to connect a terminal to the PRE for local administrative access.
- Auxiliary port (AUX)—This asynchronous EIA/TIA-232 serial port is used to connect a modem to the PRE for remote administrative access.
- Ethernet port (ETH)—This Ethernet port is used to connect the PRE to a 10/100BASE-T network management LAN.

## PCMCIA Card Slots

Two PCMCIA Type II card slots can store the Cisco IOS image or a system configuration file on a flash memory card. The system can also boot from the software stored on the flash memory card. See [“Figure 5-47 Removing the PCMCIA Flash Card” section on page 5-45](#) for more information about inserting and removing flash cards from the PRE.

## PRE LED Indicators and Switches

LEDs on the front panel of the PRE provide a visual indication showing the status of PRE operation (see [Figure 1-6](#)). The LEDs are separated into three categories:

- alarms
- status
- failure

Alarm relay contacts on the Cisco 10008 router let you connect the router to a site alarm maintenance system. This allows critical, major, and minor alarms generated by the Cisco 10008 router to be displayed on both the PRE front panel and to external visual or audible alarms connected to the system. See the [“Connecting Alarm Indicators” section on page 3-26](#) for more information about alarm connections.

Pressing the alarm cutoff (ACO) switch on the (primary) PRE during an alarm condition shuts off the external alarm, but does not deactivate the alarm LEDs on the PRE front panel. Alarm LEDs on the front panel are deactivated only after the condition that caused the alarm is corrected.

[Table 1-3](#) describes the LEDs and switch on the PRE.

**Table 1-3 LEDs and Cutoff Switch**

LEDs/Switch	Status	Description
<b>Ethernet Port LEDs:</b>		
Activity	Green	Packets are being transmitted and received.
	Off	No packet activity.
Link	Green	Carrier detected; the port is able to pass traffic.
	Off	No carrier detected; the port is not able to pass traffic.
PCMCIA slot 0	Green	Flash card in Slot 0 is active.
PCMCIA slot 1	Green	Flash card in Slot 1 is active.
Critical, Major, and Minor LEDs	Off	No alarm.
	Yellow	Indicates an alarm condition.
Alarm cutoff (ACO) switch	—	Pressing this switch disables an audible alarm.



**Table 1-3 LEDs and Cutoff Switch**

LEDs/Switch	Status	Description
Status	Green	PRE is ready.
	Off	No power to the PRE.
Fail	Off	The PRE is operating properly.
	Yellow	A major failure has disabled the PRE.

## Alphanumeric Display

The small alphanumeric display on the front panel provides information on the state of the PRE. The display consists of two four-character LED panels. Table 1-4 lists the most common messages and explains what they mean. If you report a problem to Cisco, it is helpful to include the message on the PRE's alphanumeric display in your problem report.

**Table 1-4 Messages on PRE Alphanumeric Display**

Message	PRE Status
1111, 2222, 3333, 4444, 5555, 6666, 7777, 8888, 9999 AAA, BBB, CCC	The PRE has just been powered on and is running its power-on self-test.
ROM DONE	The PRE has loaded the ROM monitor. This message appears briefly if the system is configured to boot a Cisco IOS software image. If the system is not configured to boot Cisco IOS, this message remains on the display and the rommon prompt appears on the terminal window.
AUTO BOOT	The ROM monitor is preparing to boot a Cisco IOS image.
BOOT IMGE	A Cisco IOS image is starting to boot.
IOS STRT, IOS EXC, IOS FPGA, IOS FPOK, IOS FILE, IOS STBY, IOS INTF, IOS MEM, IOS DRVR, IOS LIB, IOS MGMT, IOS PROT, IOS CONF	These messages appear in quick succession during the boot process.
---- ----	[On the primary PRE.] The PRE has finished booting and is running Cisco IOS. This is the normal operating status for the primary PRE.
IOS STBY	[On the secondary PRE.] The PRE is standing by; it is ready to take over if the primary PRE fails. This is the normal operating status for the secondary PRE.

## Disposing of the PRE

The PRE contains a small lithium battery. Some jurisdictions restrict the ways in which you may dispose of items containing lithium batteries. In particular, never dispose of lithium batteries or products containing lithium batteries in an unregulated fire. Other restrictions might apply in your area.



**Warning**

**Ultimate disposal of this product should be handled according to all national laws and regulations.**  
Statement 1040





## CHAPTER 2

# Preparing for Installation

---

Before you install the Cisco 10008 router, consider:

- The power and cabling requirements that must be in place at your installation site
- The equipment required to install the router
- The environmental conditions your installation site must meet to maintain normal operation

This chapter guides you through the process of preparing for your router installation.

Do not unpack the system until you are ready to install it. Keep the chassis in the shipping container to prevent accidental damage until you determined an installation site. Use the appropriate unpacking documentation included with the system.

This chapter contains the following sections:

- [Site Planning, page 2-1](#)
- [Safety, page 2-11](#)
- [Preventing Electrostatic Discharge Damage, page 2-12](#)
- [Electrical Safety, page 2-13](#)
- [Electrical Safety, page 2-13](#)
- [Receiving the Cisco 10000 Series Router, page 2-14](#)
- [Required Tools and Equipment, page 2-16](#)

## Site Planning

This section contains site planning information, and will help you plan for the installation of the Cisco 10008 router. It contains the following sections:

- [Cisco Professional Installation](#)
- [Site Selection Guidelines](#)
- [Floor Loading Considerations](#)
- [Site Power Requirements](#)
- [Site Cabling Guidelines](#)
- [Rack-Mounting and Location Guidelines, page 2-8](#)
- [Rack-Mounting and Location Guidelines](#)
- [Site Planning Checklist](#)

## Cisco Professional Installation

Professional installation of the Cisco 10008 router is available through the Cisco Professional Services group. This includes advance site planning, configuring the router to your requirements, and testing the installed system.

For more information about professional installation, talk to your Cisco sales representative.

## Site Selection Guidelines

The Cisco 10008 router requires specific environmental operating conditions. Temperature, humidity, altitude, and vibration can affect the performance and reliability of the router. The following sections provide specific information to help you plan for the proper operating environment.

## Site Environmental Requirements

Environmental monitoring in the Cisco 10008 series router protects the system and components from damage caused by excessive voltage and temperature conditions. To ensure normal operation and avoid unnecessary maintenance, plan and prepare your site configuration *before* installation. After installation, make sure the site maintains the environmental characteristics as shown in [Table 2-1](#).

**Table 2-1 Cisco 10008 Router Environmental Tolerances**

Environmental Characteristic	Minimum	Maximum
Temperature, ambient operating (short-term operating temperature is limited to 131°F (55C) in compliance with Telcordia GR-63.)	41 degrees F (5 degrees C)	104 degrees F (40 degrees C)
Temperature, ambient nonoperating and storage	−40 degrees F (−40 degrees C)	158 degrees F (70 degrees C)
Humidity, ambient (noncondensing) operating	5 percent	85 percent
Humidity, ambient (noncondensing) nonoperating and storage	5 percent	95 percent
Altitude, operating and nonoperating	−197 ft (−60 m)	13,123 ft (4000 m)
Vibration, operating	—	5 to 200 Hz, 0.5 g (1 octet/min.)
Vibration, nonoperating	—	5 to 200 Hz, 1 g (1 octave/min.) 200 to 500 Hz, 2 g (1 octave/min.)

## Heat Dissipation

Like all electronic equipment, the Cisco 10008 router chassis and components produce heat when turned on and operating. You must assess the site's air conditioning capacity, and ensure it can compensate for the heat dissipation of the system. [Table 2-2](#) shows the maximum BTUs dissipated by the Cisco 10008 chassis with an AC PEM and all line cards installed.

**Table 2-2 Heat Dissipation of Cisco 10000 Series Router**

Chassis Type	Heat Dissipation
Cisco 10008	4770 Btu/hr

## Physical Characteristics

Be familiar with the physical characteristics of the Cisco 10008 router to assist you in placing the system in the proper location. [Table 2-3](#) shows the weight and dimensions of the Cisco 10008 router chassis.

**Table 2-3 Physical Characteristics of Cisco 10000 Series Router**

Characteristic	Cisco 10008
Height	21.75 in. (55.2 cm)
Width	17.5 in. (44.4 cm)
Depth	13.4 in. (30.4 cm) Some configurations may require 14.5 in.
Weight of fully configured chassis	130 lb (59.02 kg)

## Floor Loading Considerations

Ensure that the floor under the rack supporting the Cisco 10008 series router is capable of supporting the combined weight of the rack and all other installed equipment.

To assess the weight of the fully configured Cisco 10008 chassis respectively, refer to [Table 2-3](#).

For additional information about floor loading requirements, consult the document *GR-63-CORE, Network Equipment Building System (NEBS) Requirements: Physical Protection*.

## Site Power Requirements

The Cisco 10008 router has specific power and electrical wiring requirements. Adhering to these requirements ensures reliable operation of the system. The following sections specify the electrical service and circuit requirements.

Follow these precautions and recommendations when planning power connections to the Cisco 10008 router:

- Check the power at your site before installation and periodically after installation to ensure that you are receiving clean power. Install a power conditioner if necessary.
- Provide proper grounding to avoid damage from lightning and power surges.



### Caution

This product requires short-circuit (overcurrent) protection, to be provided as part of the building installation. Install only in accordance with national and local wiring regulations.

**Note**

The Cisco 10008 router installation must comply with all applicable codes and is approved for use with copper conductors only. The ground bond fastening hardware should be of compatible material and preclude loosening, deterioration, and electrochemical corrosion of hardware and joined material. Attachment of the chassis ground to a central office or other interior ground system should be made with a 6-AWG, copper ground conductor at a minimum.

## Electrical Service Requirements

The building's electrical wiring supplying power to the Cisco 10008 series router must comply with all applicable building electrical codes. Also, the installation must comply with the following requirements:

- **Wiring must have copper conductors.** Copper conductor is the only electrical wire conductor approved for use with the Cisco 10008 series router.
- **Ground bond fastening hardware** must be of compatible material and resist loosening or deteriorating. Also, the joined hardware materials must resist electrochemical corrosion.
- **Chassis grounding** must be provided to avoid damage to the equipment due to lightning striking power lines or due to power surges. The chassis ground must be attached to a central office or other interior ground system with a copper ground conductor of 6 AWG (minimum).
- **Short-circuit (overcurrent) protection** must be provided as part of the building installation. Install only in accordance with national and local wiring regulations.
- **Power conditioning** must be installed if the power surges or has spikes.
- **2-poled disconnect device** must be incorporated in the fixed circuit wiring for emergency power shutdown.

## Electrical Circuit Requirements

Each Cisco 10008 router requires a dedicated electrical circuit. If you equip it with dual power feeds, provide a separate circuit for each PEM to avoid compromising the power redundancy feature.

The Cisco 10008 router can be powered by a DC or AC source. Ensure the equipment grounding is in compliance with local and national electrical codes.

The following sections contain specific recommendations for AC and DC powered systems.

### AC Powered Systems

The Cisco 10008 router chassis' AC PEM uses a short power cord with a male IEC 320 C20 AC inlet power connector and a strain relief device (canoe). This cord mates to an AC power cord consisting of a female IEC 320 C19 connector on one end, and a connector compatible with the building's AC receptacle on the other end. When you order the chassis, you must specify the type of connector you need to ensure compatibility with the building's AC receptacle.

The electrical ratings of the Cisco 10008 router chassis AC PEM are:

- AC input voltage: 100 to 240 VAC
- AC input frequency: 50/60 Hz, single phase
- AC input current: 15 to 7A
- Input power consumption: 1400W maximum

## DC Powered Systems

The DC PEMs for the Cisco 10008 router chassis are not shipped with wiring to connect to the DC source. Both systems have terminal blocks to attach building's input, return, and earthing (ground) wiring. The DC power source must comply with the Safety Extra Low Voltage (SELV) requirements in IEC 60950 based safety standards.

The electrical ratings of the DC PEMs for both the Cisco 10008 chassis are:

- DC input voltage:
  - Nominal range –48 VDC to –60 VDC
  - Absolute maximum range –40.5 VDC to –75 VDC
- DC input current: 20A @ –48 VDC
- Power consumption: 1300W maximum

**Warning**

---

**You must incorporate a readily accessible 2-poled disconnect device in the fixed wiring.**  
Statement 1022

---

See [Appendix A, “Technical Specifications,”](#) for system power specifications, including input voltage and operating frequency ranges.

## Site Cabling Guidelines

This section contains guidelines for wiring and cabling at your site. When preparing your site for network connections to the Cisco 10008 series router, consider the type of cable required for each line card, and the cable's limitations. Consider the distance limitations for signaling, EMI, and connector compatibility. Possible cable types are fiber, thick or thin coaxial, foil twisted-pair, or unshielded twisted-pair cabling.

Also consider any additional interface equipment you need, such as transceivers, hubs, switches, modems, channel service units (CSUs), or data service units (DSUs).

Before you install the Cisco 10008 series router, have all additional external equipment and cables on hand. For ordering information, contact a customer service representative.

The extent of your network and the distances between network interface connections depend in part on the following factors:

- Signal type
- Signal speed
- Transmission medium

The distance and rate limits referenced in the following sections are the IEEE-recommended maximum speeds and distances for signaling purposes. Use this information as a guideline in planning your network connections *prior to* installing the Cisco 10008 router.

## Interference Considerations

When wires are run for any significant distance in an electromagnetic field, interference can occur between the field and the signals on the wires. This fact has two implications for the construction of plant wiring:

- Bad wiring practice can result in radio interference emanating from the plant wiring.
- Strong EMI, especially when it is caused by lightning or radio transmitters, can destroy the signal drivers and receivers in the Cisco 10008 router, and can even create an electrical hazard by conducting power surges through lines and into equipment. (Review the safety warnings in the [“Preventing Electrostatic Discharge Damage”](#) section on page 2-12.)

**Note**

To predict and remedy strong EMI, you may also need to consult experts in radio frequency interference (RFI).

If you use twisted-pair cable in your plant wiring with a good distribution of grounding conductors, the plant wiring is unlikely to emit radio interference. If you exceed the recommended distances, use a high-quality twisted-pair cable with one ground conductor for each data signal when applicable.

If wires exceed recommended distances, or if wires pass between buildings, give special consideration to the effect of a lightning strike in your vicinity. The electromagnetic pulse caused by lightning or other high-energy phenomena can easily couple enough energy into unshielded conductors to destroy electronic devices. If you have had problems of this sort in the past, you may want to consult experts in electrical surge suppression and shielding.

## Asynchronous Terminal Connections

The PRE provides a Console Port to connect a terminal or computer for local console access. The PRE also provides an Auxiliary Port to connect to a modem for remote dial-in console access.

Both ports have RJ-45 connectors, support RS-232 asynchronous data, and have distance recommendations specified in the IEEE RS-232 standard.

## Ethernet Connections

The distance you can extend your networks or the distances between them depends on the type of signal, signal speed, and transmission media used. The following sections detail recommendations for Ethernet connections.

### Ethernet and Fast Ethernet over Twisted-Pair

Ethernet (10BaseT) and Fast Ethernet (100BaseT) signaling is typically over twisted-pair cabling. The IEEE has specific distance limitations detailed in IEEE standard 802.3, but industry experience has shown that connections remain reliable at speeds and distances far greater than these. If you choose to exceed the distances and speeds recommended by the IEEE, you do so at your own risk.

[Table 2-4](#) shows the distance limits for Ethernet 10BaseT and 100BaseT signal types over twisted-pair cabling.



**Table 2-4 Ethernet and Fast Ethernet Maximum Transmission Distances**

Signal Type	Transceiver Speed	Cable Type	Transmission Mode	IEEE Maximum Distance Between Stations
10BaseT Ethernet	10 Mbps	Category 3 twisted-pair	Full and half duplex	328 ft (100 m)
100BaseT Fast Ethernet	100 Mbps	Category 5 twisted-pair	Full and half duplex	328 ft (100 m)

## Setting Up Fiber-Optic Connections

For other fiber-optic specifications, see the [Cisco 10000 Series Routers Line Card Hardware Installation Guide](#).

## Interference Considerations

When wires are run for any significant distance, there is a risk that stray signals will be induced on the wires as interference. If interference signals are strong, they can cause data errors or damage to the equipment.

The following sections describe sources of interference and how to minimize its effects on the Cisco 10008 router.

### Electromagnetic Interference

All equipment powered by AC current can propagate electrical energy that can cause electromagnetic interference (EMI) and possibly affect the operation of other equipment. The typical sources of EMI are equipment power cords and power service cables from electric utility companies.

Strong EMI can destroy the signal drivers and receivers in the Cisco 10008 router and even create an electrical hazard by causing power surges through power lines into installed equipment. These problems are rare, but could be catastrophic.

To resolve these problems, you need specialized knowledge and equipment, which could consume substantial time and money. However, you should ensure that you have a properly grounded and shielded electrical environment, paying special attention to the need for electrical surge suppression.

### Radio Frequency Interference

When electromagnetic fields act over a long distance, radio frequency interference (RFI) can be propagated. Building wiring can often act as an antenna, receiving the RFI signals and creating more EMI on the wiring.

If you use twisted-pair cable in your plant wiring with a good distribution of grounding conductors, the plant wiring is unlikely to emit radio interference. If you exceed the recommended distances, use a high-quality twisted-pair cable with one ground conductor for each data signal.

### Lightning and AC Power Fault Interference

If signal wires exceed recommended cabling distances, or if signal wires pass between buildings, you should consider the effect that a lightning strike in your vicinity might have on the Cisco 10008 router.

The electromagnetic pulse (EMP) generated by lightning or other high-energy phenomena can couple enough energy into unshielded conductors to damage or destroy electronic equipment. If you have previously experienced such problems, you should consult with RFI/EMI experts to ensure that you have adequate electrical surge suppression and shielding of signal cables in your Cisco 10008 series router operating environment.

## Rack-Mounting and Location Guidelines

You can mount the Cisco 10008 router on an equipment shelf or tabletop. However, we recommend rack-mounting the Cisco 10008 router. The rack-mounting hardware included with chassis is suitable for most 19-inch equipment racks and telco-type racks.

The sections that follow describe criteria for selecting a rack to mount the Cisco 10008 series router, and guidelines for placing the rack for reliable operation.

### Rack Selection Guidelines

We recommend that you mount the Cisco 10008 router in an equipment rack, and includes the necessary rack-mounting hardware which is suitable for most 19-inch equipment and telco-type racks.

Consider installing the Cisco 10008 router in a rack with the following features:

- NEBS compliant, 19-inch (48.3 cm) wide rack; or NEBS compliant 23-inch (58.4 cm) wide rack.
- EIA or ETSI hole patterns in the mounting rails. Required mounting hardware (screws, clip nuts, and dress washers) is shipped with the Cisco 10008 series router. If the rack that you plan to install the system in has metric-threaded rails, you must provide your own metric mounting hardware.
- Perforated top and open bottom for ventilation to prevent overheating.
- Leveling feet for stability.

### Rack Configuration Guidelines

Several rack-mounting configurations are possible to provide maximum density. The following sections describe mounting configurations for the Cisco 10008 chassis.

A standard 7-foot-high rack can accommodate three Cisco 10008 chassis mounted from the front. The Cisco 10008 chassis can be flush mounted, with the front of the chassis being flush with the rack's mounting rails, or mid-mounted to bring the front of the chassis half-way out from the mounting rails.

Bracket extenders are required to mid-mount the Cisco 10008 chassis in a 23-inch telco rack. For more information on mid-mounting, see [Chapter 3, "Installing the Cisco 10008 Router."](#)

You can double the port density of a 7 ft. rack by installing six Cisco 10008 chassis back-to-back using three High-Density Rack Kits (available from Cisco). Each kit includes all the necessary hardware to mount one pair of back-to-back 10008 chassis on a sliding tray that allows access to the rear of the chassis. The kit also includes a baffle kit to control the flow of exhaust air. The High-Density Rack Kit can only be used with racks with the features described below:

- A rack with 3-inch or 6-inch U-channel
- A four-post cabinet rack with front and rear RETMA rails installed

## Rack Placement Guidelines

The placement of the rack can affect personnel safety, system maintenance, and the system's ability to operate within the environmental characteristics described in [Table 2-1 on page 2-2](#). Choose a proper location for the Cisco 10000 series router by following the guidelines below.

### Locating for Safety

If the Cisco 10008 router is the heaviest, or the only piece of equipment in the rack, consider installing it at or near the bottom to ensure that the rack's center of gravity is as low as possible.

For additional information about the proper placement of electronic equipment, consult the document *GR-63-CORE, Network Equipment Building System (NEBS) Requirements: Physical Protection*.

### Locating for Easy Maintenance

Keep at least 3 feet of clear space in front and behind the rack. This space ensures that you can remove the Cisco 10008 router cards and perform routine maintenance and upgrades easily.

Avoid installing the Cisco 10008 router in a congested rack, and consider how the routing of cables from other pieces of equipment in the same rack could affect access to the routers cards.

Temperature sensors on the PRE monitor the internal air temperature and send warning messages and an alarm condition when the internal air temperature approaches a specified threshold.

The front and top of the chassis must remain unobstructed to ensure adequate airflow and prevent overheating inside the chassis.

Allow the following clearances for normal system maintenance:

At the top of the chassis—At least 3 inches (7.6 cm)

In the front of the chassis—3 to 4 ft (91.44 cm to 121.92 cm)

To avoid problems during installation and ongoing operation, follow these general precautions when you plan the equipment locations and connections:

- Use the **show environment** command regularly to check the internal system status. The environmental monitor continually checks the interior chassis environment; it provides warnings for high temperature and creates reports on any occurrences. If warning messages are displayed, take immediate action to identify the cause and correct the problem.
- Keep the Cisco 10008 router off of the floor and out of areas that collect dust.
- Follow ESD prevention procedures to avoid damage to equipment. Damage from static discharge can cause immediate or intermittent equipment failure.
- Ensure that the PRE modules, line cards, blank covers, power supplies, and any power supply covers are in place and secure. The fans direct cooling air throughout the chassis interior; a loose component or empty slot can redirect the airflow away from active components.

### Locating for Proper Airflow

Ensure the location of the Cisco 10008 router has enough airflow to keep the system operating within the environmental characteristics described in [Table 2-1 on page 2-2](#), and the air temperature is sufficient to compensate for the heat dissipated by the system as specified in [Table 2-2 on page 2-3](#).

Avoid locating the Cisco 10008 router in a location in which the chassis air intake vents could draw in the exhaust air from adjacent equipment. Consider how the air flows through the Cisco 10008 router, and be aware that the airflow of the Cisco 10008 chassis is different as described in the following sections.

The Cisco 10008 chassis draws cooling air in through the intake vent in the front and moves the air across the internal components and out the exhaust vents on the top rear of the chassis, as illustrated in Figure 2-1.

**Figure 2-1 Cisco 10008 Chassis Airflow**

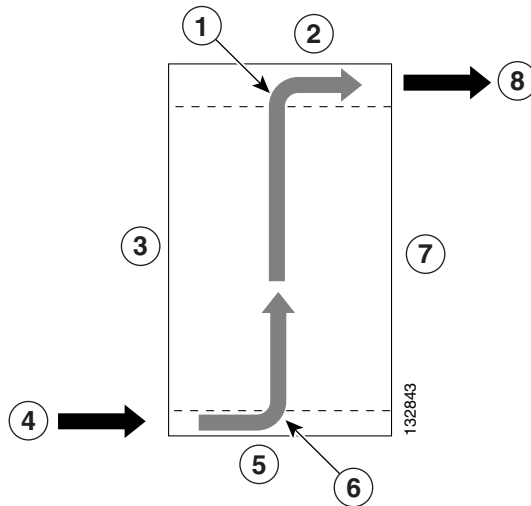

<b>1</b>	Blower module (fans)	<b>5</b>	Bottom
<b>2</b>	Top	<b>6</b>	Air filter assembly
<b>3</b>	Front	<b>7</b>	Rear
<b>4</b>	Ambient air intake	<b>8</b>	Exhaust air

Keep the front and top of the Cisco10008 chassis clear to ensure proper airflow and prevent overheating inside the chassis. Allow at least 3 inches of clearance between the top of the chassis and the equipment above to ensure proper airflow.

## Site Planning Checklist

Table 2-5 is provided to help you perform and account for all the site planning tasks presented in this appendix.

**Table 2-5 Site Planning Checklist**

	Site Planning Requirements
	The site meets the environmental requirements ( <a href="#">Site Environmental Requirements, page 2-2</a> ).
	The site's air conditioning system can compensate for the heat dissipation of the Cisco 10000 series ( <a href="#">Heat Dissipation, page 2-2</a> ).
	The floor space that the Cisco 10000 series router occupies can support the weight of the system ( <a href="#">Floor Loading Considerations, page 2-3</a> ).
	Electrical service to the site complies with the requirements ( <a href="#">Electrical Service Requirements, page 2-4</a> ).
	The electrical circuit servicing the Cisco 10000 series router complies with the requirements ( <a href="#">Electrical Circuit Requirements, page 2-4</a> ).
	Consideration has been given to the console port wiring, and limitations of the cabling involved, according to TIA/EIA-232F ( <a href="#">Asynchronous Terminal Connections, page 2-6</a> ).
	The Cisco 10008 router Ethernet cabling distances are within limitations ( <a href="#">Ethernet Connections, page 2-6</a> ).
	The Cisco 10008 router fiber optic cable distances are within limitations ( <a href="#">Interference Considerations, page 2-7</a> ).
	<a href="#">Interference Considerations, page 2-7</a> have been studied, and an EMI/RFI expert has been consulted if necessary.
	The equipment rack in which you plan to install the Cisco 10000 series router complies with requirements ( <a href="#">Rack Selection Guidelines, page 2-8</a> ).
	Careful consideration has been given to safety, ease of maintenance, and proper airflow in selecting the location of the rack ( <a href="#">Rack Placement Guidelines, page 2-9</a> ).

## Safety

When you install the Cisco 10008 router, observe all of the following caution and warning statements. For warning translations, refer to the [Regulatory Compliance and Safety Information for the Cisco 10000 Series Routers](#).

The following guidelines will help ensure your safety and protect the equipment. However, these guidelines may not cover all potentially hazardous situations you may encounter during system installation, so *be alert*.

- The installation of your Cisco 10008 router must comply with national and local electrical codes. In the United States, this means the National Fire Protection Association (NFPA) 70, United States National Electrical Code. In Canada, Canadian Electrical Code, part I, CC22.1. In other countries, International Electrotechnical Commission (IEC) 364, part 1 through part 7.
- Review the safety warnings listed in the [Regulatory Compliance and Safety Information for the Cisco 10000 Series Routers](#) document, before installing, configuring, or performing maintenance on the product.

- Never attempt to lift an object that might be too heavy to lift safely by yourself.
- Always unplug the power cable before you install or remove a chassis.
- Keep the chassis area clear and as dust free as possible during and after installation.
- Keep tools and chassis components away from walk areas.
- Do not wear loose clothing, jewelry (including rings and chains), or other items that could get caught in the chassis.
- The AC-powered Cisco 10008 router ships with a three-wire AC electrical grounding-type plug, which fits into a grounding-type power outlet only. This is a safety feature. Ensure the equipment grounding is in compliance with local and national electrical codes.
- The DC-powered Cisco 10008 router is not shipped with wiring to connect to the DC source. You must provide input, return, and earthing (grounding) wiring at the site, and install and protect the wiring in accordance with local and national wiring regulations (see [Table 3-2 on page 3-18](#)).
- The Cisco 10008 router operates safely when it is used in accordance with its marked electrical ratings and product usage instructions.

**Warning**

**Only trained and qualified personnel should be allowed to install or replace this equipment**  
Statement 49

## Preventing Electrostatic Discharge Damage

Electrostatic discharge (ESD) damage, which occurs when electronic cards or components are improperly handled, can result in complete or intermittent failures. The performance routing engine (PRE), and all line cards consist of a printed circuit card that is fixed in a metal carrier. Electromagnetic interference (EMI) shielding and connectors are integral components of the carrier. Although the metal carrier helps to protect the cards from ESD, use an antistatic strap each time you handle the modules. Handle the carriers by the edges only; never touch the cards or connector pins.

**Caution**

Always tighten the captive installation screws on all system components when you are installing them. These screws prevent accidental removal of the module, provide proper grounding for the system, and help to ensure that the bus connectors are properly seated in the backplane.

Following are guidelines for preventing ESD damage:

- Always use an ESD-preventive wrist or ankle strap and ensure that it makes good skin contact. Before removing a card from the chassis, connect the equipment end of the strap to the ESD plug at the bottom of the chassis below the power entry modules ([Figure 2-2](#)).
- Handle line cards by the faceplates and carrier edges only; avoid touching the card components or any connector pins.
- When removing a line card, place the removed module component-side-up on an antistatic surface or in a static-shielding bag. If the module will be returned to the factory, immediately place it in a static-shielding bag.
- Avoid contact between the modules and clothing. The wrist strap protects the card from ESD voltages on the body only; ESD voltages on clothing can still cause damage.

**Caution**

For safety, periodically check the resistance value of the antistatic strap. The measurement should be between 1 and 10 megohms.

**Figure 2-2 ESD Chassis Connection**

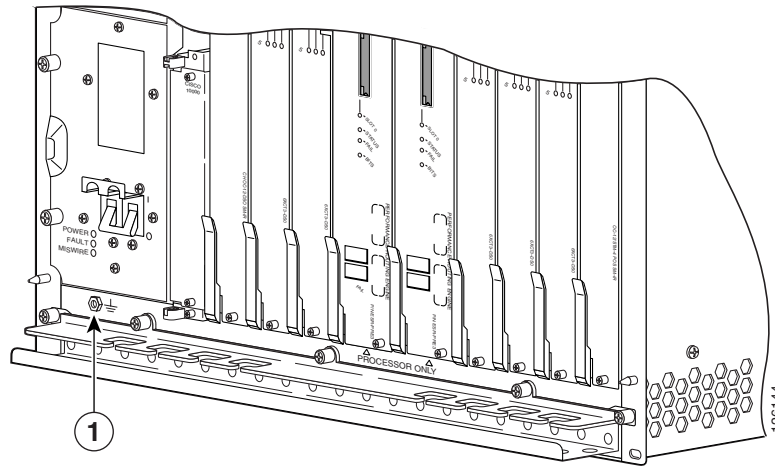

1	ESD socket
---	------------

## Electrical Safety

All system components are hot-swappable. They are designed to be removed and replaced while the system is operating without presenting an electrical hazard or damage to the system.

Follow these basic guidelines when you are working with any electrical equipment:

- Before beginning any procedures requiring access to the chassis interior, locate the emergency power-off switch for the room in which you are working.
- Disconnect all power and external cables before installing or removing a chassis.
- Do not work alone when potentially hazardous conditions exist.
- Never assume that power has been disconnected from a circuit; always check.
- Do not perform any action that creates a potential hazard to people or makes the equipment unsafe. Never install equipment that appears damaged.
- Carefully examine your work area for possible hazards such as moist floors, ungrounded power extension cables, and missing safety grounds.

In addition, use the guidelines that follow when working with any equipment that is disconnected from a power source but is still connected to telephone wiring or other network cabling.

- Never install telephone wiring during a lightning storm.
- Never install telephone jacks in wet locations unless the jack is specifically designed for wet locations.
- Never touch uninsulated telephone wires or terminals unless the telephone line has been disconnected at the network interface.

- Use caution when installing or modifying telephone lines.



Warning

**Do not work on the system or connect or disconnect cables during periods of lightning activity.** Statement 1001



Warning

**Before you work on equipment that is connected to power lines, remove jewelry (including rings, necklaces, and watches). Metal objects will heat up when connected to power and ground and the heat can cause serious burns or weld the metal object to the terminals.** Statement 43



Warning

**Read the installation instructions before you connect the system to its power source.** Statement 1004

## Receiving the Cisco 10000 Series Router

Each Cisco 10000 series router chassis is shipped in a container that is strapped to a pallet as illustrated in Figure 2-3, and includes the physical dimensions listed in Table 2-6.

**Table 2-6** Shipping Dimensions and Weight of Cisco 10008 Router

Chassis	Height	Length	Width
10008	33 in. (84 cm)	33 in. (84 cm)	24 in. (61 cm)

**Figure 2-3** Cisco 10000 Series Router Packaged for Shipping

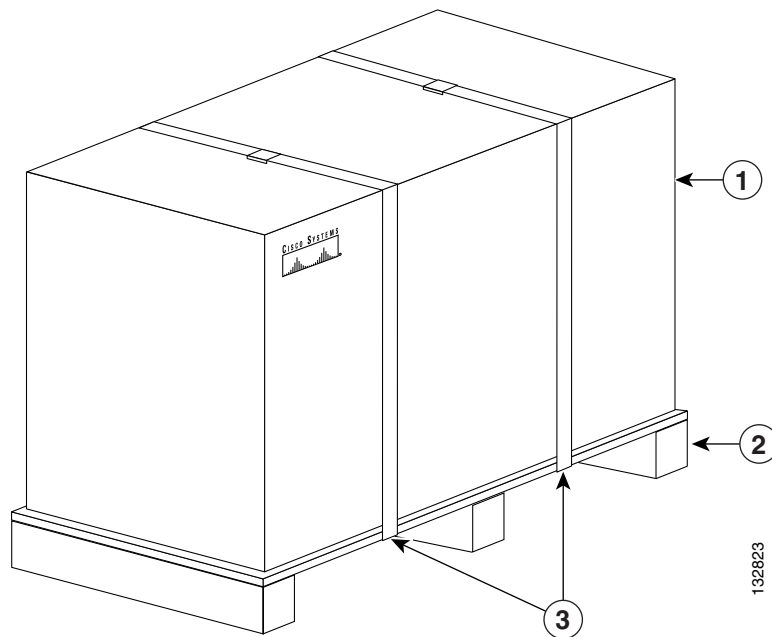

1	Outside carton	3	Packing straps
2	Pallet		



After you receive the Cisco 10008 router, we recommend that you have three people available to help with the installation and ensure safe lifting.

## Chassis-Lifting Guidelines

The fully configured system weighs approximately 130 pounds. The chassis is not intended to be moved frequently. Before you install the system, ensure that your site is properly prepared so you can avoid having to move the chassis later to accommodate power sources and network connections.

Two or more people are required to lift the chassis. Each time you lift the chassis or any heavy object, follow these guidelines:

- Never attempt to lift the chassis by yourself. Because of the size and weight of the chassis, use at least two people to safely lift and move it without causing injury or damaging the equipment.
- Ensure that your footing is solid, and balance the weight of the chassis between your feet.
- Lift the chassis slowly; never move suddenly or twist your body as you lift.
- Keep your back straight and lift with your legs, not your back. If you must bend down to lift the chassis, bend at the knees, not at the waist, to reduce the strain on your back muscles.
- Do not remove installed components from the chassis.
- Always disconnect all external cables before lifting or moving the chassis.

To safely lift the chassis, perform the following steps:



**Warning**

**Two people are required to lift the chassis. To prevent injury, keep your back straight and lift with your legs, not your back.** Statement 164

**Figure 2-4** *Lifting the Chassis*

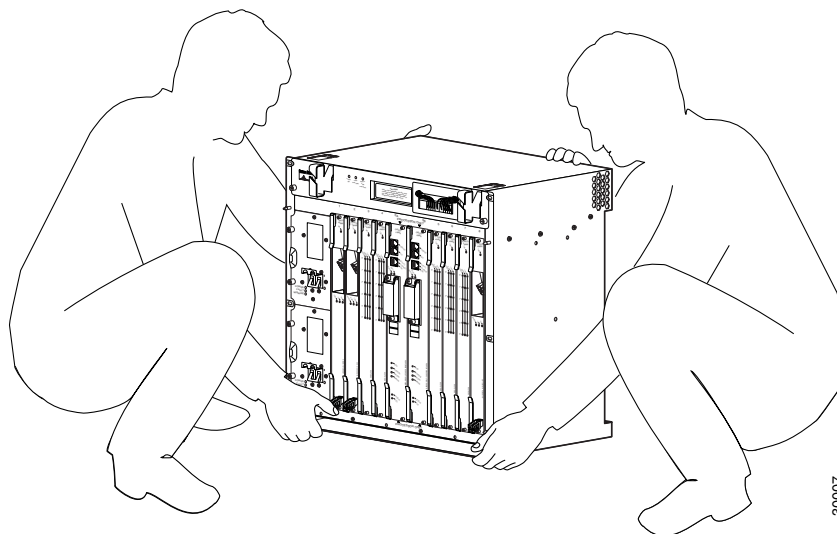

- Step 1** Each person should stand on either side of the chassis, and place one hand under the air intake at the bottom front of the chassis.

- Step 2** With the other hand, grasp the top rear of the chassis under the air exhaust and carefully lift the chassis as shown in [Figure 2-4](#).
- 

## Required Tools and Equipment

The tools and equipment listed below are recommended as the minimum necessary to install the Cisco 10008 router. You may need additional tools and equipment to install associated equipment and cables. You may also require test equipment to check electronic and optical signal levels, power levels, and communications links.

- Number 2 Phillips screwdriver
- A 3/16-inch flat-blade screwdriver
- A 1/4-inch flat-blade screw driver
- Antistatic mat or antistatic foam
- An electrostatic discharge (ESD) grounding strap or the disposable ESD strap shipped with the system
- Tape measure (optional)
- Level (optional)

Refer to the [“Connecting the Chassis to Ground”](#) section on page 3-13 for specific tool and equipment requirements to connect the chassis to ground.

## Verifying Contents After Unpacking

Power cables, manuals, and other additional items are packaged in separate boxes. After you have unpacked the system to verify that you have received all of the required components. Using the packing list as a guide, take the following steps to check the contents of the Cisco 10008 router shipping container:

- 
- Step 1** Check the contents of the boxes containing accessory items. Verify that you have received all equipment listed in your order, including the following:
- System hardware and software documentation
  - Any optional equipment that you ordered, such as transceivers (GBICs), flash cards, cables, or special connectors
- Step 2** Check that all line cards you ordered are installed in the chassis (including PCMCIA flash cards installed in the PRE). Ensure that the configuration matches the packing list.
-



# CHAPTER 3

## Installing the Cisco 10008 Router

---

This chapter describes the procedures for installing the Cisco 10008 router on a tabletop or in equipment racks. It also describes how to connect interface and power cables, the proper way to power on the system, and installation troubleshooting procedures.



### Note

---

The illustrations in this guide depict the original Cisco 10008 chassis. Your chassis may appear or look slightly different, but the installation procedure is the same.

---

This chapter contains the following sections:

- [Installation Methods, page 3-1](#)
- [Rack-Mounting the Chassis, page 3-2](#)
- [Non-Rack Installation, page 3-11](#)
- [Connecting the Chassis to Ground, page 3-13](#)
- [Connecting DC Power to the Cisco 10008 Router, page 3-17](#)
- [Connecting AC Power to the Cisco 10008 Router, page 3-22](#)
- [Connecting Alarm Indicators, page 3-26](#)
- [Connecting a Video Terminal to the PRE Console Port, page 3-30](#)
- [Connecting Network Management and Signal System Cables, page 3-32](#)

## Installation Methods

Although rack-mounting is the preferred method of installation for the Cisco 10008 router, you can mount the router in an alternate location, such as on an equipment shelf or on a tabletop.

A rack-mount and cable-management kit is shipped with the Cisco 10008 router.

For mounting the chassis in a:

- 19-inch wide (standard), 4-post equipment rack or telco-type equipment rack, use the rack-mount brackets in the kit.
- 23-inch wide equipment rack, order optional rack-mount brackets to fit the 23-inch rack.

The cable-management bracket relieves the strain on interface cables connected to the PRE and line card modules in the chassis.

If you are installing the chassis on an equipment shelf, on a tabletop, or using mounting hardware other than that supplied with the chassis, then go to the [“Non-Rack Installation” section on page 3-11](#).

## Rack-Mounting the Chassis

Rack-mounting the chassis is the preferred method of installation for the Cisco 10008 router. This section explains how to install the rack-mount and cable-management bracket on the Cisco 10008 chassis for the following types of installations:

- [Flush-Mounting in a 19-Inch Rack, page 3-3](#)
- [Center-Mounting in a 19-Inch Rack, page 3-5](#)
- [Center-Mounting in a 23-Inch Rack, page 3-7](#) (requires optional 23-inch bracket kit)

## General Rack Installation Guidelines

When planning your rack installation, consider the following guidelines:

- The Cisco 10008 chassis requires a minimum of 13 rack units (22.3 inches or 56.6 cm) of vertical rack space. Measure the proposed rack location before mounting the chassis in the rack.
- Before using a particular rack, check for obstructions (such as a power strip) that could impair rack-mount installation. If a power strip does impair a rack-mount installation, remove the power strip before installing the chassis, and then replace it after the chassis is installed.
- Allow sufficient clearance around the rack for maintenance. If the rack is mobile, you can push it back near a wall or cabinet for normal operation and pull it out for maintenance (installing or moving line cards, connecting cables, or replacing or upgrading components). Otherwise, allow 19 inches (48.3 cm) of clearance to remove FRUs.
- Maintain a minimum clearance of 3 inches (7.62 cm) on the front, top, and sides of the chassis for the cooling air inlet and exhaust ports, respectively. Avoid placing the chassis in an overly congested rack or directly next to another equipment rack; otherwise, the heated exhaust air from other equipment can enter the inlet air vents and cause an overtemperature condition inside the router.



### Caution

To prevent chassis overheating, never install a Cisco 10008 router in an enclosed rack or room that is not properly ventilated or air conditioned.

- Always install heavier equipment in the lower half of a rack to maintain a low center of gravity to prevent the rack from falling over.
- Install and use the cable-management brackets included with the Cisco 10008 router to keep cables organized and out of the way of the line cards and PREs. Ensure that cables from other equipment already installed in the rack do not impair access to the cards, or require you to disconnect cables unnecessarily to perform equipment maintenance or upgrades.
- Install rack stabilizers (if available) before you mount the chassis.
- Provide an adequate chassis ground (earth) connection for your router chassis.

In addition to the preceding guidelines, review the precautions for avoiding excessive temperature conditions in the [“Site Environmental Requirements” section on page 2-2](#).

## Flush-Mounting in a 19-Inch Rack

The Cisco 10008 chassis can be flush-mounted in a 19-inch equipment rack using the rack-mounting kit provided with your system. The rack-mounting kit contains

- Two mounting brackets
- One cable management bracket
- Mounting screws



**Warning**

**At least three people are required to mount the chassis in the equipment rack: two people are needed to hold the chassis in place while a third person tightens the mounting screws.** Statement 234

When handling the chassis, always follow proper lifting practices as outlined in the [“Electrical Safety”](#) section on page 2-13.

Use the following procedure to flush-mount the Cisco 10008 chassis in a 19-inch equipment rack:

**Figure 3-1 Attaching Chassis to Equipment Rack**

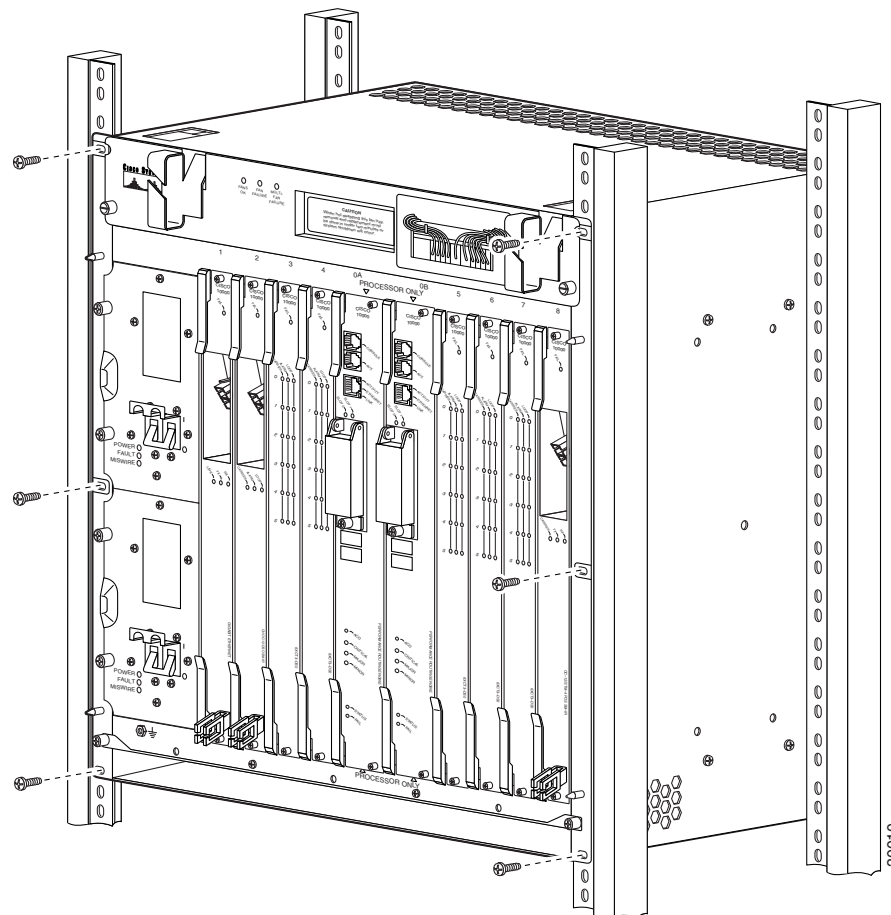

- 
- Step 1** (Optional) Install a shelf in the rack to support the Cisco 10008 chassis. If you use a shelf, you can perform the installation with only two people.
- Step 2** (Optional) Remove the blower module and the PEMs to make the chassis easier to lift.
- Step 3** Lift the chassis into position between the rack posts (requires two people).
- Step 4** Align the mounting bracket holes with the rack post holes ([Figure 3-1](#)) and attach the chassis to the rack (performed by the third person unless the chassis is resting on a shelf).

**Figure 3-2 Attaching Cable Management Bracket**

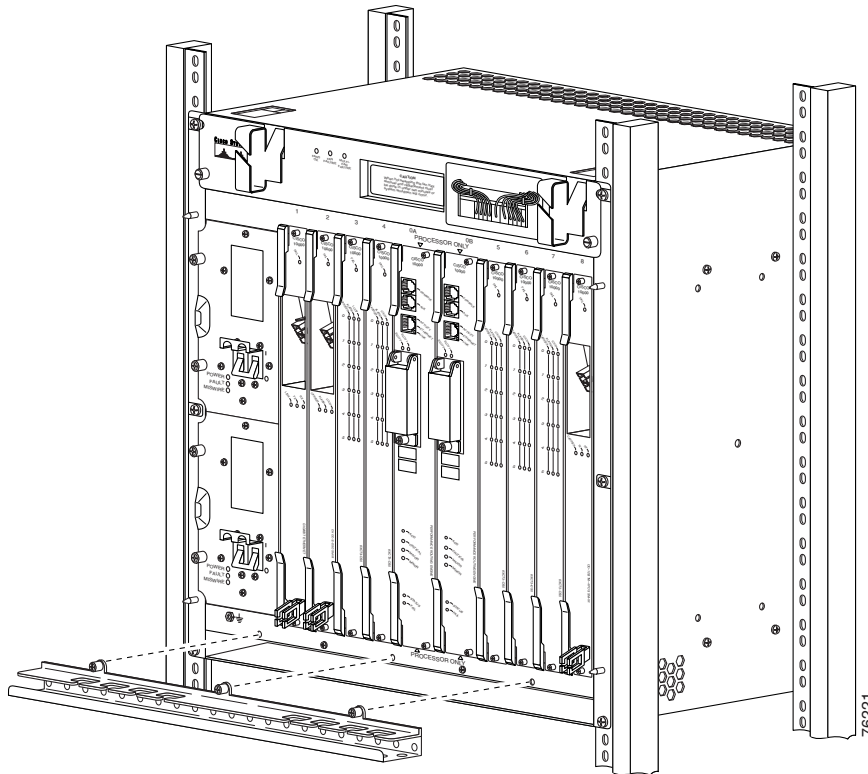

- Step 5** Attach the cable management bracket to the bottom of the chassis ([Figure 3-2](#)).



**Note** The cable management bracket consists of two pieces (the cable guide and channel), and is shipped assembled. If you want to use the cable guide only, you can remove the channel by loosening the captive screws before attaching the cable guide to the chassis.

- Step 6** Check that all
- Ejector levers are in the closed position.
  - Chassis mounting screws are tight.
  - PRE and line card captive screws are tight.
- Step 7** Go to the “[Connecting the Chassis to Ground](#)” section on [page 3-13](#) to continue the installation.
-

## Center-Mounting in a 19-Inch Rack

The Cisco 10008 chassis can be center-mounted in a 19-inch equipment rack using the rack-mounting kit provided with your system. The rack-mounting kit contains

- Two mounting brackets
- One cable management bracket
- Mounting screws

When handling the chassis, always follow proper lifting practices as outlined in the [“Electrical Safety”](#) section on page 2-13.



**Warning**

**At least three people are required to mount the chassis in the equipment rack: two people are needed to hold the chassis in place while a third person tightens the mounting screws.** Statement 234

Use the following procedure to flush-mount the Cisco 10008 chassis in a 19-inch equipment rack:

**Figure 3-3** *Attaching Mounting Brackets to Chassis*

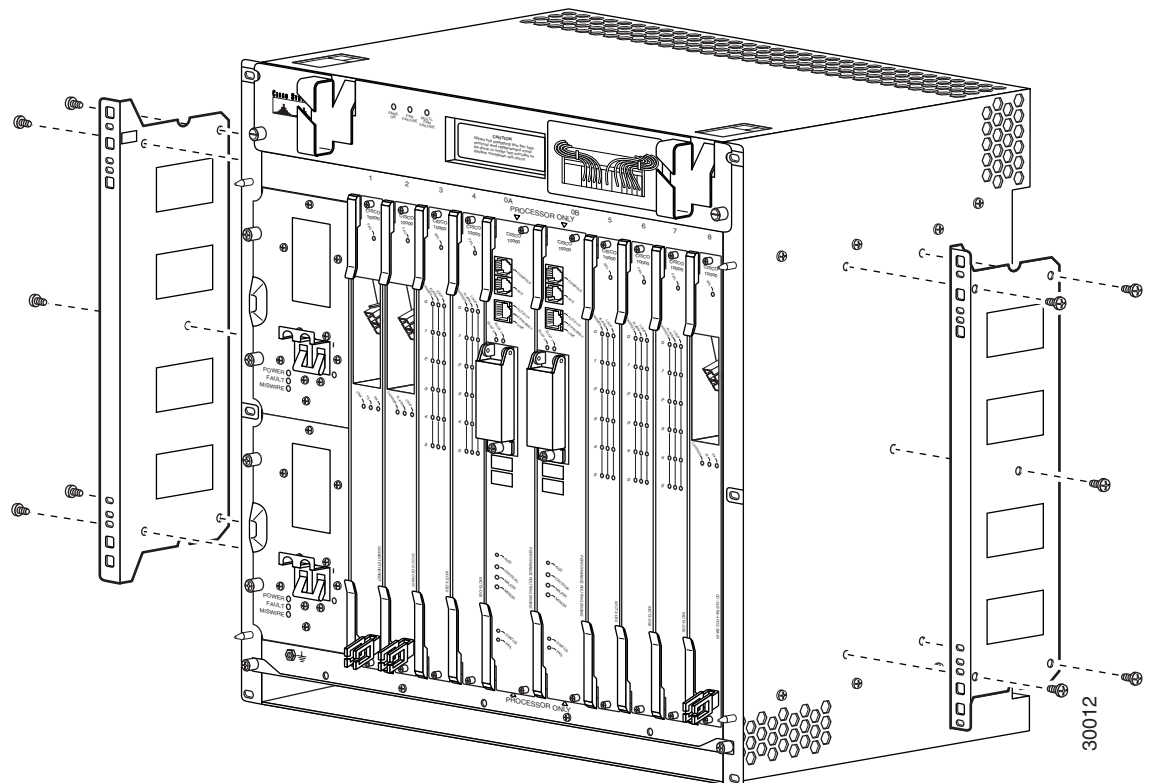

- Step 1** Attach the two mounting brackets to the chassis so the flanges are positioned at the center of the chassis (Figure 3-3).

**Figure 3-4 Attaching Chassis to Equipment Rack**

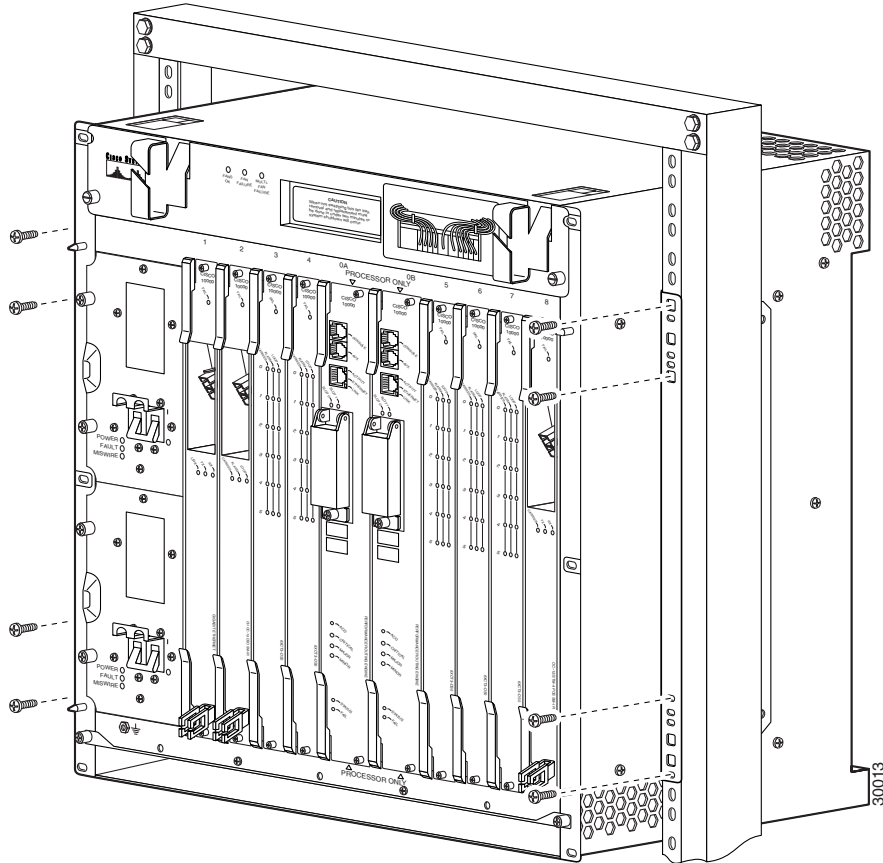

- Step 2** Lift the chassis into position between the rack posts (requires two people).
- Step 3** Align the mounting bracket holes with the rack post holes (Figure 3-4) and attach the chassis to the rack (performed by the third person).



**Note** The cable management bracket consists of two pieces (the cable guide and channel), and is shipped assembled. If you want to use the cable guide only, you can remove the channel by loosening the captive screws before attaching the cable guide to the chassis.



**Figure 3-5** Attaching Cable Management Bracket

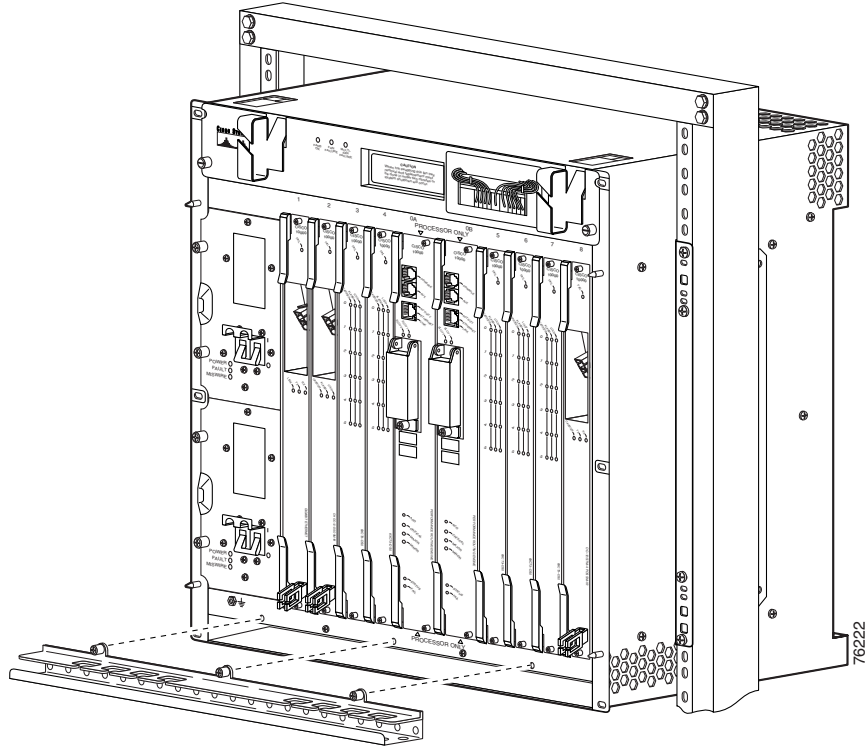

- Step 4** Attach the cable management bracket to the bottom of the chassis (Figure 3-5).
- Step 5** Check that all
- Ejector levers are in the closed position.
  - Chassis mounting screws are tight.
  - PRE and line card captive screws are tight.
- Step 6** Go to the “Connecting the Chassis to Ground” section on page 3-13 to continue the installation.

## Center-Mounting in a 23-Inch Rack

The Cisco 10008 chassis can be center-mounted in a 23-inch equipment rack using an optional rack-mounting kit (not provided with your system). The optional rack-mounting kit contains

- Two mounting brackets
- One cable management bracket
- Mounting screws



### Warning

**At least three people are required to mount the chassis in the equipment rack: two people are needed to hold the chassis in place while a third person tightens the mounting screws.** Statement 234

Use the following procedure to flush-mount the Cisco 10008 chassis in a 23-inch equipment rack:

**Figure 3-6** Attaching Mounting Brackets to Chassis

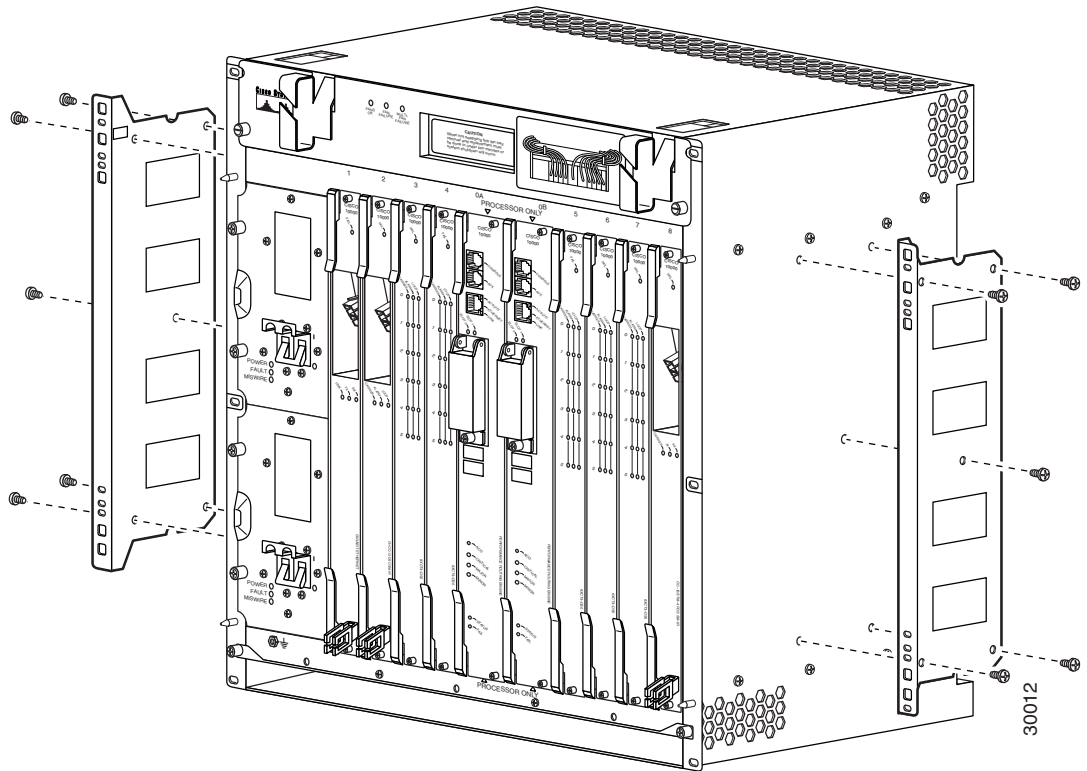

- Step 1** Attach the two mounting brackets to the chassis so the flanges are positioned at the center of the chassis (Figure 3-6).

**Figure 3-7** Attaching 23-inch Bracket Adapters

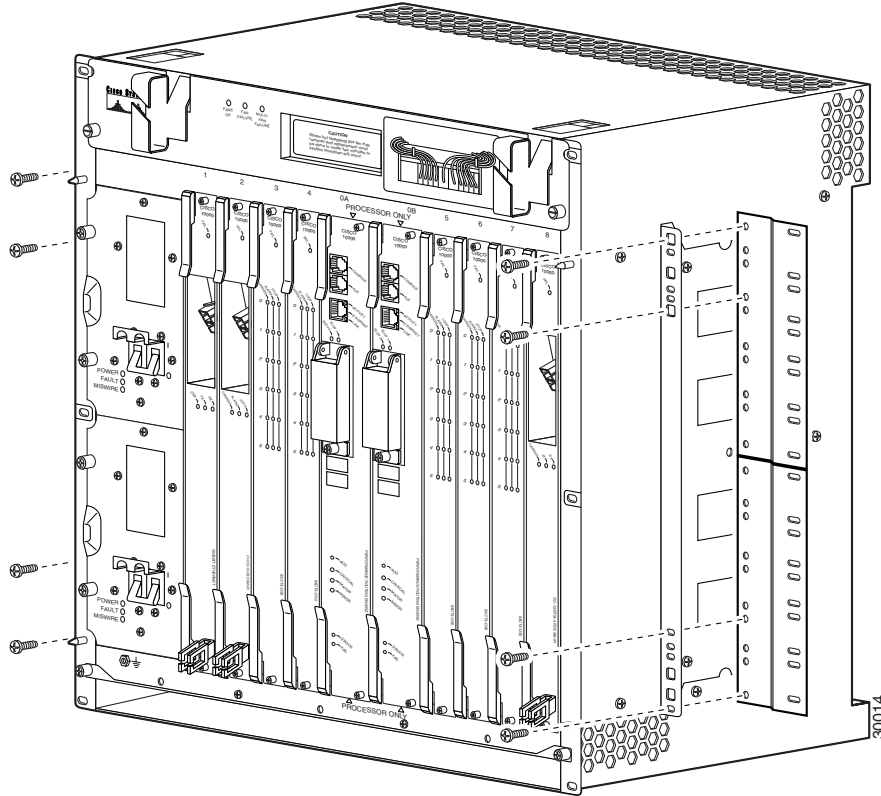

**Step 2** Attach the optional 23-inch adapters to the mounting brackets (Figure 3-7).

**Figure 3-8** Attaching Chassis to Equipment Rack

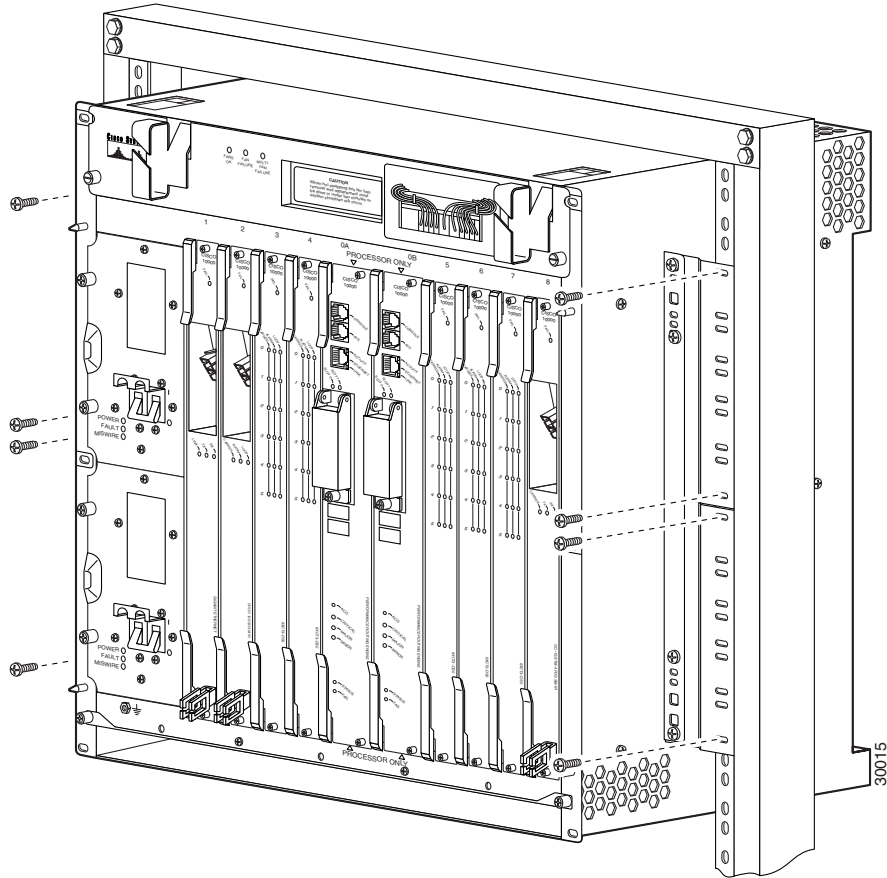

- Step 3** Lift the chassis into position between the rack posts (requires two people).
- Step 4** Align the mounting bracket holes with the rack post holes ([Figure 3-8](#)) and attach the chassis to the rack (performed by the third person).

**Figure 3-9** Attaching the Cable Management Bracket

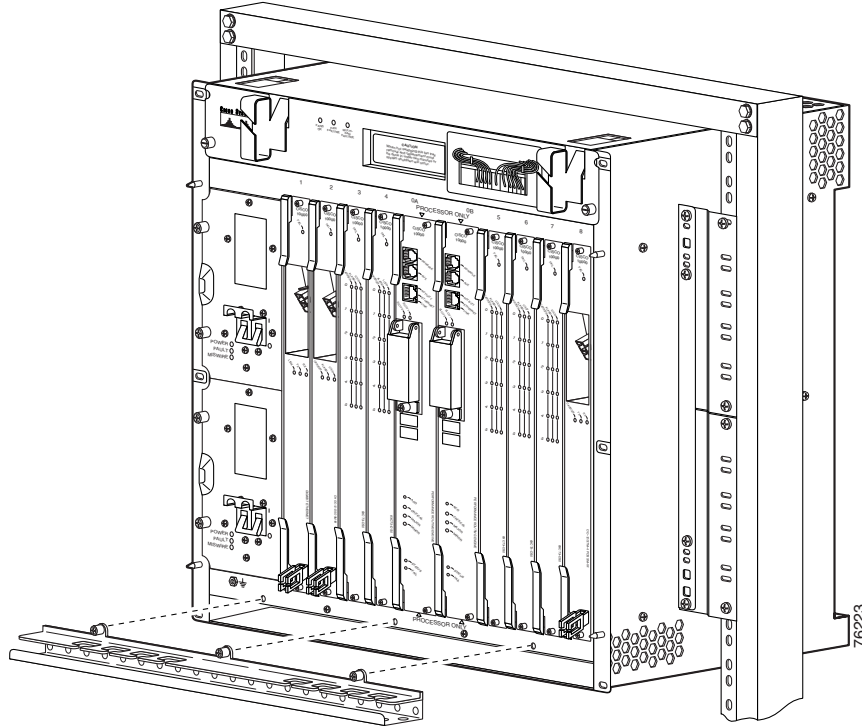

**Step 5** Attach the cable management bracket to the bottom of the chassis ([Figure 3-9](#)).



**Note** The cable management bracket consists of two pieces (the cable guide and channel), and is shipped assembled. If you want to use the cable guide only, you can remove the channel by loosening the captive screws before attaching the cable guide to the chassis.

**Step 6** Check that all

- Ejector levers are in the closed position.
- Chassis mounting screws are tight.
- PRE and line card captive screws are tight.

**Step 7** Go to the [“Connecting the Chassis to Ground”](#) section on [page 3-13](#) to continue the installation.

## Non-Rack Installation

The chassis should already be in the area where you will install it. If you have not determined where to install your chassis, see the [“Receiving the Cisco 10000 Series Router”](#) section on [page 2-14](#) for information about site considerations.

When installing the Cisco 10008 router on a workbench or tabletop, ensure that the surface is clean and that you have considered the following:

- The Cisco 10008 router requires at least 3 inches (7.62 cm) of clearance at the inlet and exhaust vents (the front and top/rear sides of the chassis).
- The Cisco 10008 router should be installed off the floor. Dust that accumulates on the floor is drawn into the interior of the router by the cooling fans. Excessive dust inside the router can cause overtemperature conditions and component failures.
- There must be approximately 19 inches (48.3 cm) of clearance at the front and rear of the chassis to install and replace FRUs, or to access network cables and equipment.
- The Cisco 10008 router needs adequate ventilation. Do not install it in an enclosed cabinet where ventilation is inadequate.
- Have the cable-management bracket available if you plan to install it on the front of the chassis.
- An adequate chassis ground (earth) connection exists for your router chassis (see the “[Connecting the Chassis to Ground](#)” section on page 3-13).
- Always follow proper lifting practices as outlined in the “[Electrical Safety](#)” section on page 2-13, when handling the chassis.

Use the following procedure to install the Cisco 10008 router on a tabletop or equipment shelf:

**Step 1** Remove any debris and dust from the tabletop or equipment shelf, as well as the surrounding area.

**Step 2** Lift the chassis into position on the tabletop or equipment shelf.



**Warning**

**Two people are required to lift the chassis. To prevent injury, keep your back straight and lift with your legs, not your back.** Statement 164

**Figure 3-10** *Lifting the Chassis*

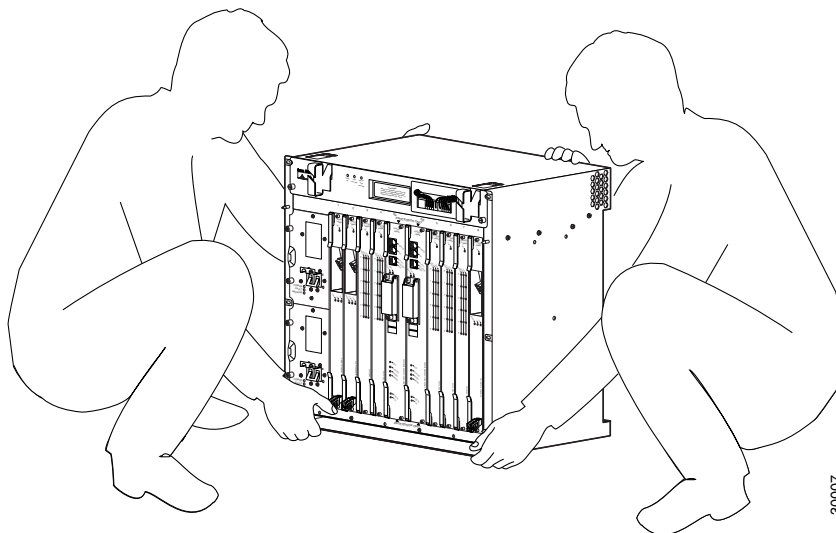

30007

**Note**

The cable management bracket consists of two pieces (the cable guide and channel), and is shipped assembled. If you want to use the cable guide only, you can remove the channel by loosening the captive screws before attaching the cable guide to the chassis.

**Figure 3-11 Attaching Cable Management Bracket**

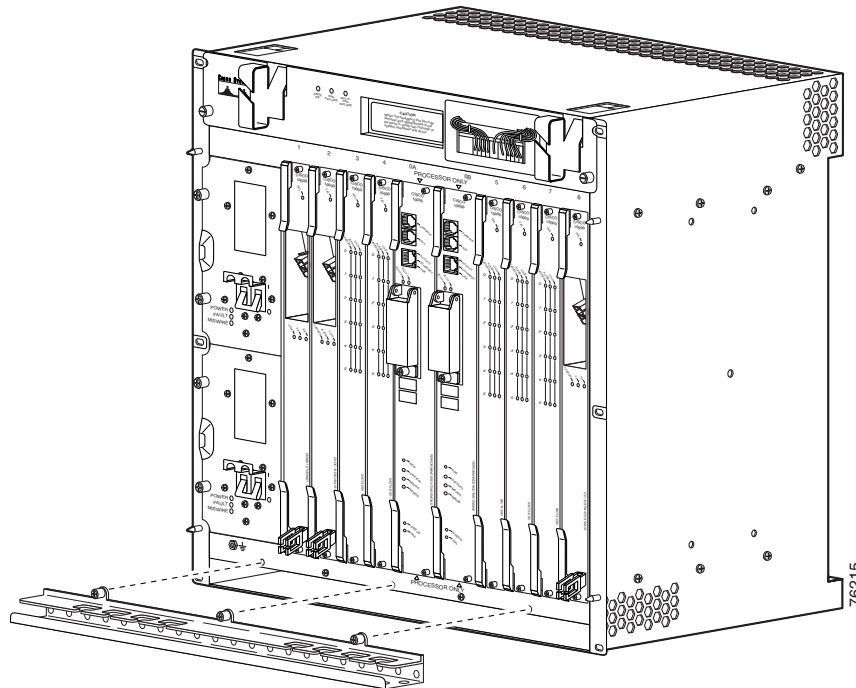

- Step 3** Attach the cable management bracket to the bottom of the chassis if you are using it (Figure 3-11).
- Step 4** Check that all
- Ejector levers are in the closed position.
  - PRE and line card captive screws are tight.
- Step 5** Go to the “[Connecting the Chassis to Ground](#)” section on page 3-13 to continue the installation.

## Connecting the Chassis to Ground

Connecting the Cisco 10008 chassis to earth ground is required for all DC powered installations, and any AC powered installation where compliance with Telcordia (formerly Bellcore) grounding requirements is necessary. Have the recommended tools and supplies available before you begin this procedure (see Table 3-1).

**Warning**

**Never defeat the ground conductor or operate the equipment in the absence of a suitably installed ground conductor. Contact the appropriate electrical inspection authority or an electrician if you are uncertain that suitable grounding is available.** Statement 93

## Recommended Tools and Supplies

Table 3-1 lists the tools, equipment, and supplies necessary to connect the system ground to the chassis.

**Table 3-1** *Tools and Supplies*

Quantity	Description	Comments
1	Number 2 Phillips screwdriver	—
1	Wire stripping tool	—
1	Crimping tool	Must fit diameter of grounding lugs.
2	2-hole grounding lugs Must fit no. 6 stranded, no. 6 weld, or 37/24 flex cables. Each lug has two holes, centered 0.625 in. (1.587 cm) apart and accepts M5 screws.	Recommended types: <ul style="list-style-type: none"> <li>• Panduit no. LCD6-10-AL</li> <li>• Thomas &amp; Betts no. 256-30695-1183</li> <li>• Burndy no. YA6CL2TC10</li> </ul>
Varies	Grounding wire	6 AWG, 0.1620 in. (4.1148 mm) recommended.
2	M5 PEM screws with captive, locking washers	Included in accessory kit shipped with the Cisco 10008 router.
Varies	Screws to attach ground wire to grounding point at site	Part requirements depend on location.

## Attaching the Grounding Cable

The following procedure describes how to attach:

- The grounding lug to the grounding cable.
- The grounding cable to the chassis.
- The grounding cable to the earth grounding point.



**Warning**

**When you install the unit, you must always connect the ground connection first and then be sure to disconnect the ground connection last.** Statement 202

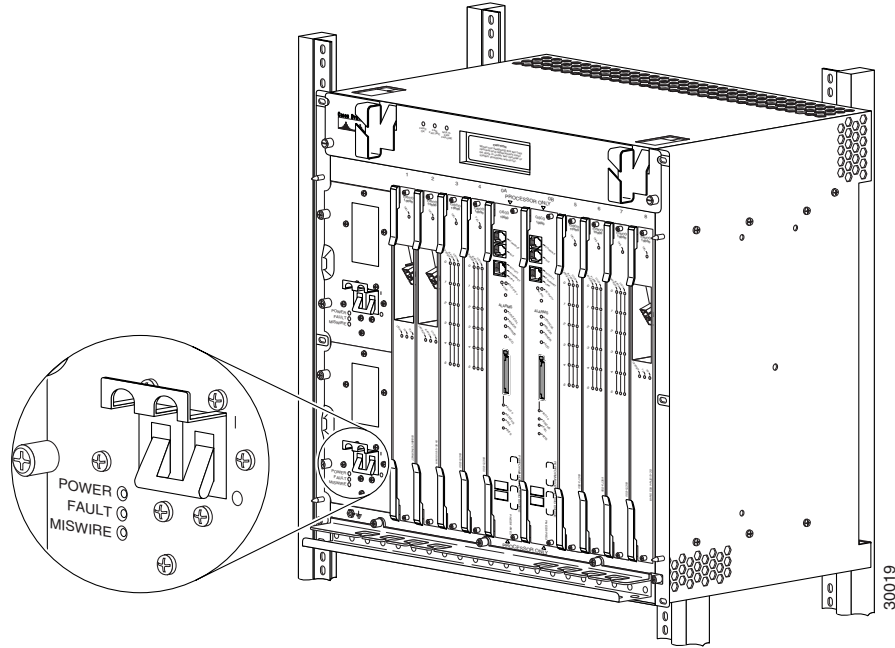

**Figure 3-12** Setting PEM Switches to the Off Position

- Step 1** Power off the chassis by setting the DC or AC PEM power switch (or switches) to the Off position (see [Figure 3-12](#) for an example of the DC PEM power switches).
- Step 2** Strip about 3/4 inch (2 cm) of the covering from the end of the grounding wire (see [Figure 3-13](#)).
- Step 3** Insert the stripped end of the grounding wire into the open end of a grounding lug and crimp the grounding lug securely to the wire ([Figure 3-13](#)).

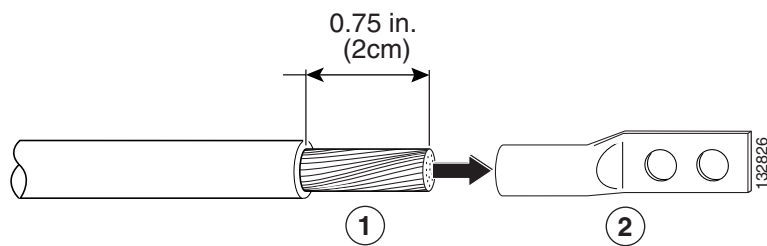
**Figure 3-13** Attaching Grounding Wire to Grounding Lug

<b>1</b>	Wire	<b>2</b>	Grounding lug
----------	------	----------	---------------

**Figure 3-14** Connecting Grounding Lug to Chassis

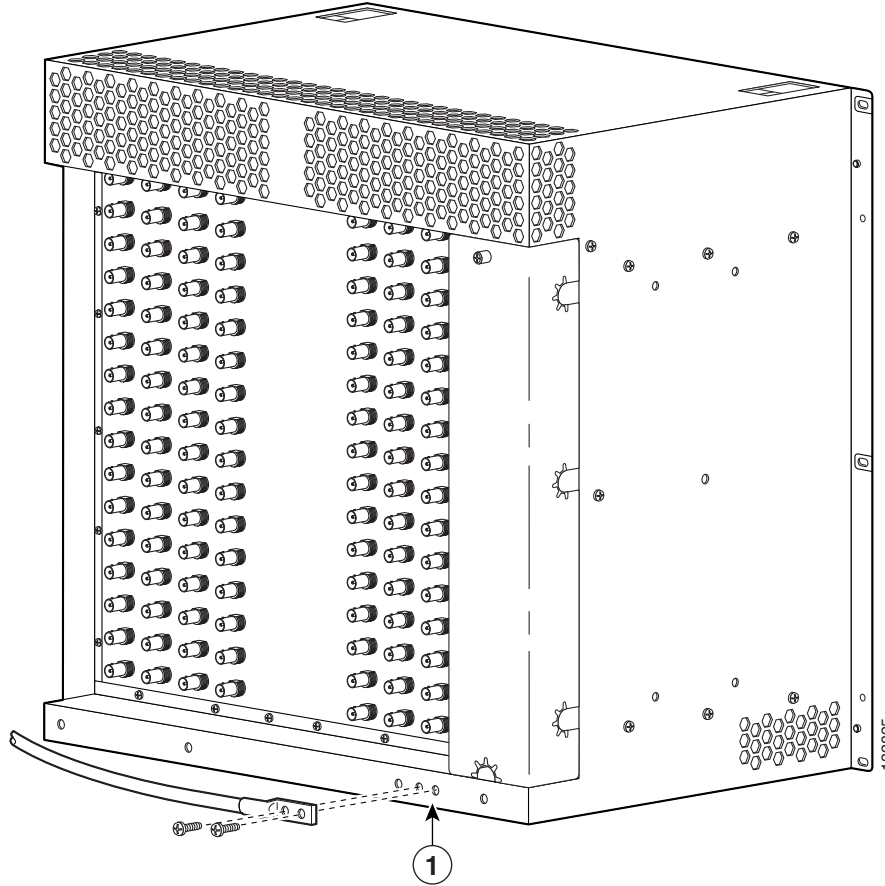

<b>1</b>	Threaded grounding holes (2)	
----------	------------------------------	--

**Step 4** Attach the grounding lug firmly to threaded holes at the bottom rear of the chassis using two M5 screws (Figure 3-14).

**Figure 3-15** Attaching the Grounding Wire to the Grounding Lug

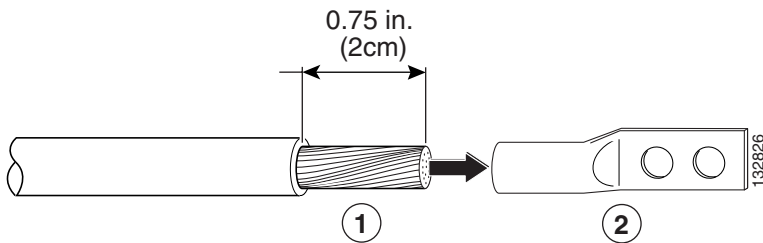

<b>1</b>	Wire	<b>2</b>	Grounding lug
----------	------	----------	---------------

**Step 5** Strip about 3/4 inch (2 cm) of the covering from the other end of the grounding wire (Figure 3-15).

- Step 6** Insert the stripped end of the grounding wire into the open end of a grounding lug and crimp the grounding lug securely to the wire (see [Figure 3-15](#)).
- Step 7** Attach the grounding lug to an appropriate grounding point at your site.
- Step 8** Go to one of the following sections to continue the installation:
- If you are connecting DC power to the system, go to the [“Connecting DC Power to the Cisco 10008 Router”](#) section on page 3-17.
  - If you are connecting AC power to the system, go to the [“Connecting AC Power to the Cisco 10008 Router”](#) section on page 3-22.
- 

## Connecting DC Power to the Cisco 10008 Router

This section describes how to connect the Cisco 10008 router to a –48 VDC power source. The power connectors are pillar terminals on the backplane. For full power redundancy, each set of DC power connectors (terminal blocks labeled A and B) must be connected to separate power sources. If you do not require power redundancy, you can use only one set of terminals—*either* the A terminal block or the B terminal block. Do not use one of each.

**Note**

If you are using AC PEMs, see the [“Connecting a Video Terminal to the PRE Console Port”](#) section on page 3-30.

---

**Warning**

**Before working on equipment that is connected to power lines, remove jewelry (including rings, necklaces, and watches). Metal objects will heat up when connected to power and ground and the heat can cause serious burns or weld the metal object to the terminals. Statement 43**

---

**Note**

Be sure that you have connected the chassis to earth ground as described in the previous section before beginning this procedure.

---

## Recommended Tools and Supplies

Table 3-2 lists the tools and supplies that you need to connect the Cisco 10008 router to DC power sources.

**Table 3-2** Tools and Supplies

Quantity	Description	Comments
1	Flat-blade screwdriver	—
1	Wire stripping tool	—
2 or 4 (length varies)	10 AWG (minimum) wire cables	Cables must reach from the Cisco 10008 router to the DC power source. <ul style="list-style-type: none"> <li>Two cables are needed for a single DC power source.</li> <li>Four cables are needed for two DC power sources.</li> </ul>
2	Tie wraps	<ul style="list-style-type: none"> <li>The end of the cable intended to be connected to the chassis needs to have insulation stripped back not more than 0.4 in. (10 mm).</li> </ul>

Use the following procedure to connect the chassis to a DC power source:

**Figure 3-16** Setting DC PEM Switches to the Off Position

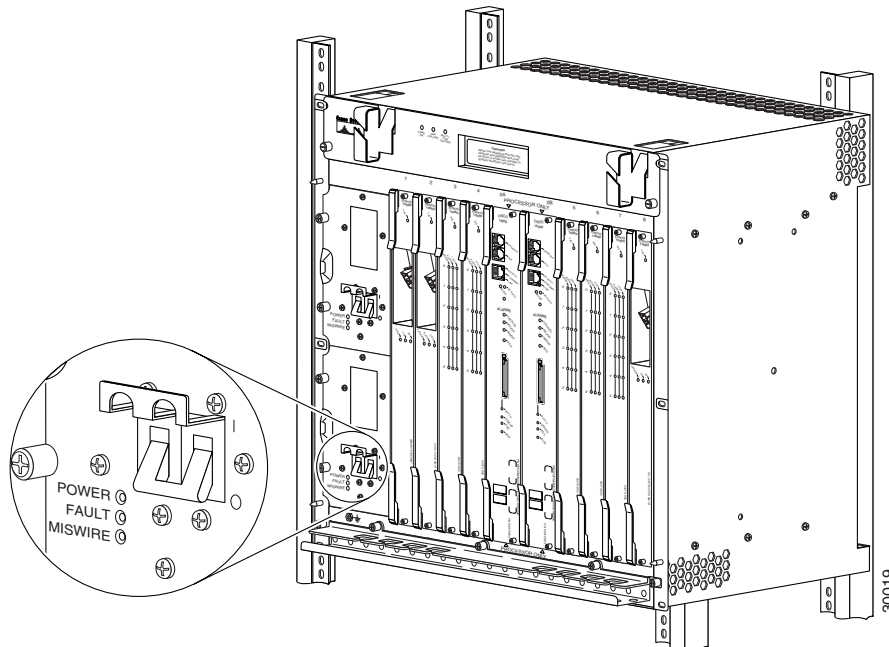

**Step 1** Set the DC PEM switch (or switches) to the Off position (Figure 3-16).



**Warning**

**This product requires short-circuit (overcurrent) protection, to be provided as part of the building installation. Install only in accordance with national and local wiring regulations.** Statement 1045

**Figure 3-17** Removing the Safety Cover

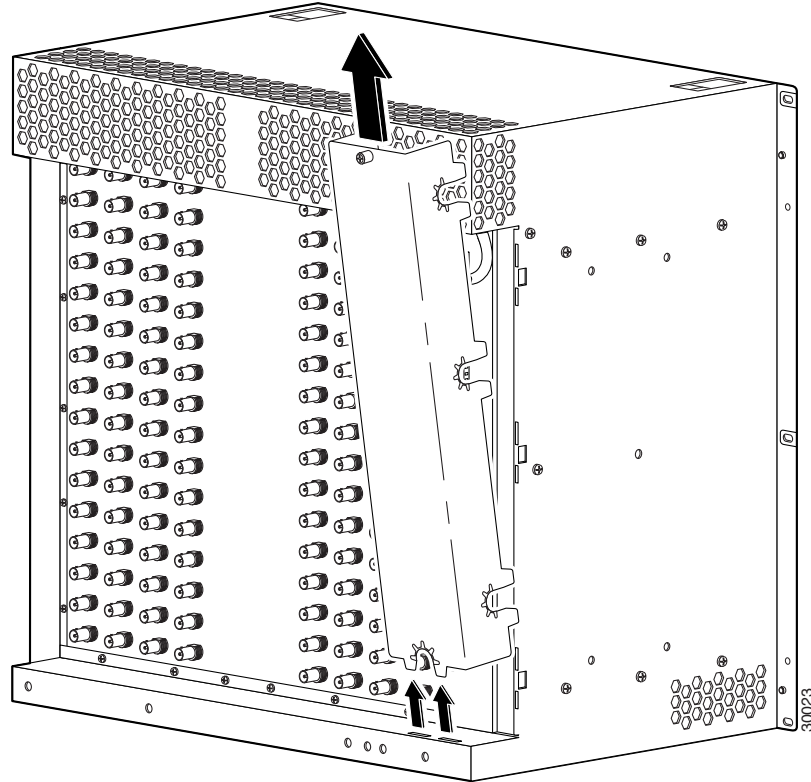

**Step 2** Loosen the captive screw on the rear safety cover and tilt the cover back (Figure 3-17).

**Figure 3-18** Removing the Rear Cover

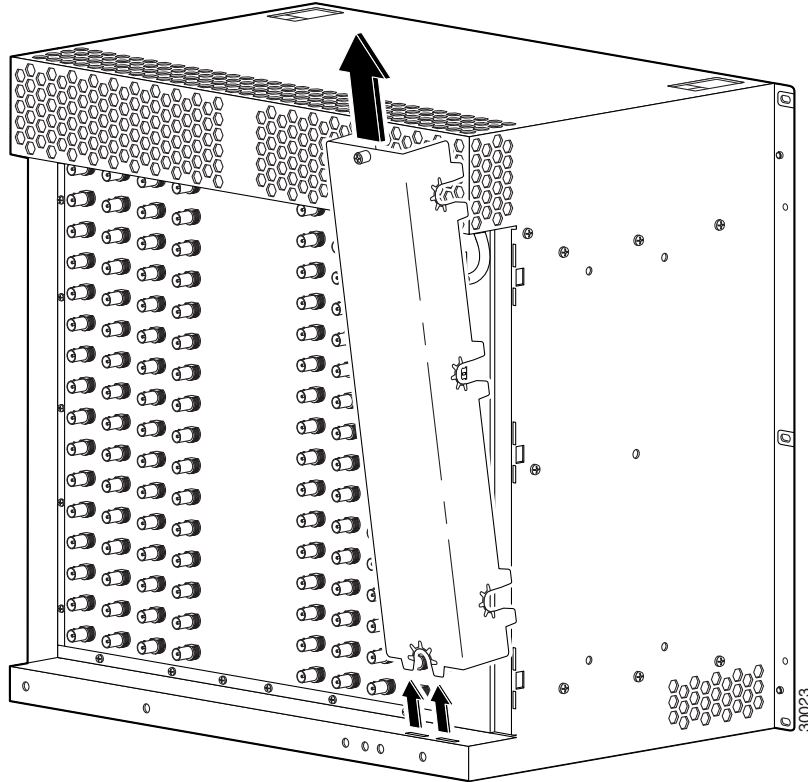

**Step 3** Remove the safety cover by lifting it up and out from the chassis (Figure 3-18).

**Figure 3-19** Stripping Insulation

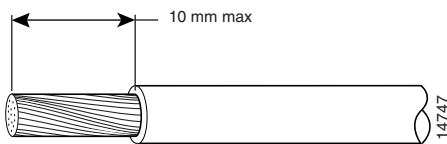

**Step 4** Strip not more than 0.4 inches (10 mm) of insulation off the ends of the DC power leads (Figure 3-19).

Figure 3-20 DC Power Connections

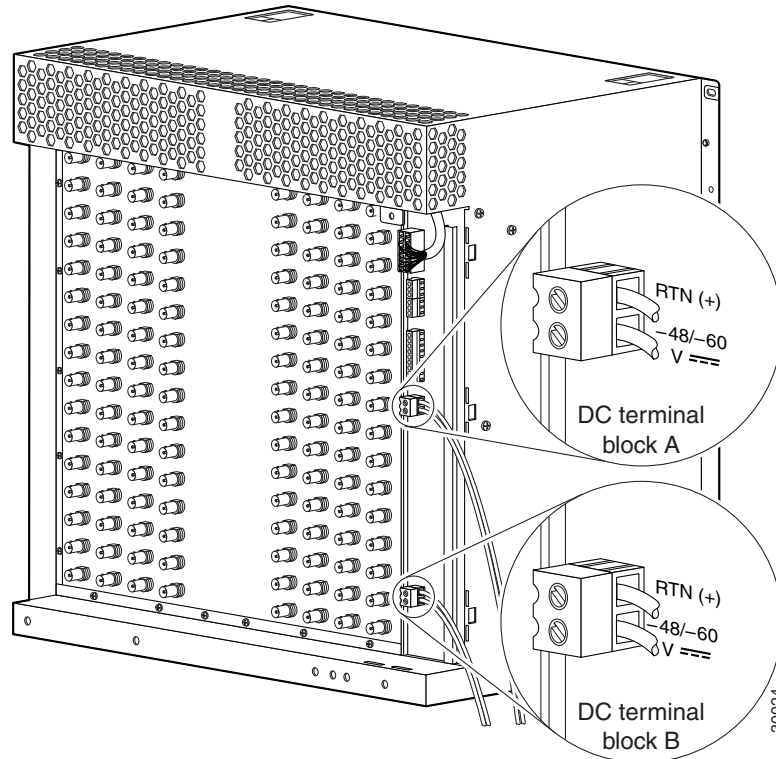

- Step 5** Connect the DC power lead from the first external power source to the DC terminal block A labeled -48V (Figure 3-20).
- Step 6** Connect the return wire (RTN) to terminal block A labeled RTN (+) (see Figure 3-20).
- If you have redundant DC power, continue with Step 7.
  - If you do not have redundant DC power, go to Step 9.
- Step 7** Connect the DC power lead from the second external power source to the DC terminal block B labeled -48V (see Figure 3-20).
- Step 8** Connect the return wire (RTN) to terminal block B labeled RTN (+) (see Figure 3-20).
- Step 9** Secure the power cabling to the chassis by feeding a tie wrap through the slot on the side of the chassis and binding the cables (see blowout in Figure 3-21).
- Step 10** If you are connecting visual or audio alarm indicators to your system, go to Step 3 of the “Connecting Alarm Indicators” section on page 3-26.
- If you are not connecting any alarm indicators, continue with the next step.

**Figure 3-21** DC Power Cables Exiting Safety Cover

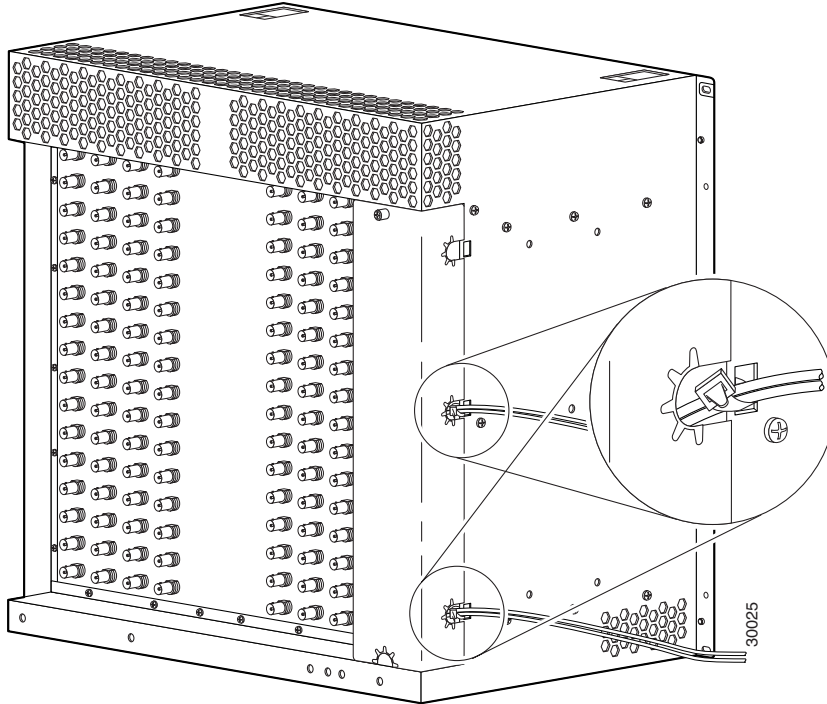

- Step 11** Replace the rear safety cover, making sure that the power wires exit through the holes on the side of the cover (Figure 3-21).
- Step 12** Go to the [“Connecting a Video Terminal to the PRE Console Port”](#) section on page 3-30 to continue the installation.

## Connecting AC Power to the Cisco 10008 Router

The Cisco 10008 router can be powered directly from the facility VAC input through the AC PEM (100-240VAC). The AC PEM is provided with an IEC 320 250V, 20A power cord with a male type connector (16A rating for Europe) for the attachment of power cords used throughout the world.



**Caution**

The 20A connector on the AC PEM is incompatible with the 15A power strips that are used in most equipment racks. Wiring codes prevent the AC-input power cable from being used with the power strips in equipment racks.



**Note**

The AC power cord that connects to the PEM power cord and then to the building VAC is not shipped with the Cisco 10008 router. You must order this power cord separately.



There are five styles of AC-input power supply power cords available (differing in plug type); make sure you have the correct style for your site (see [Table 3-3](#), [Figure 3-22](#), and [Figure 3-23](#).) All AC-input power supply power cords measure 14 feet (4.3 m). Cisco recommends that you:

- Install an uninterruptible power source where possible.
- Install proper grounding to avoid damage from lightning and power surges (see “[Attaching the Grounding Cable](#)” section on page 3-14).

[Table 3-3](#) lists the nominal and acceptable value ranges for source AC power.

**Table 3-3 Source AC Power Specifications**

Specifications	Nominal Value	Acceptable Range
AC input voltage	100 to 240 VAC, single phase	90 to 255 VAC
AC input line frequency	50/60 Hz	47 to 63 Hz
AC input current	15 A @100 VAC 7 A @240 VAC	—

**Figure 3-22 AC Power Cords**

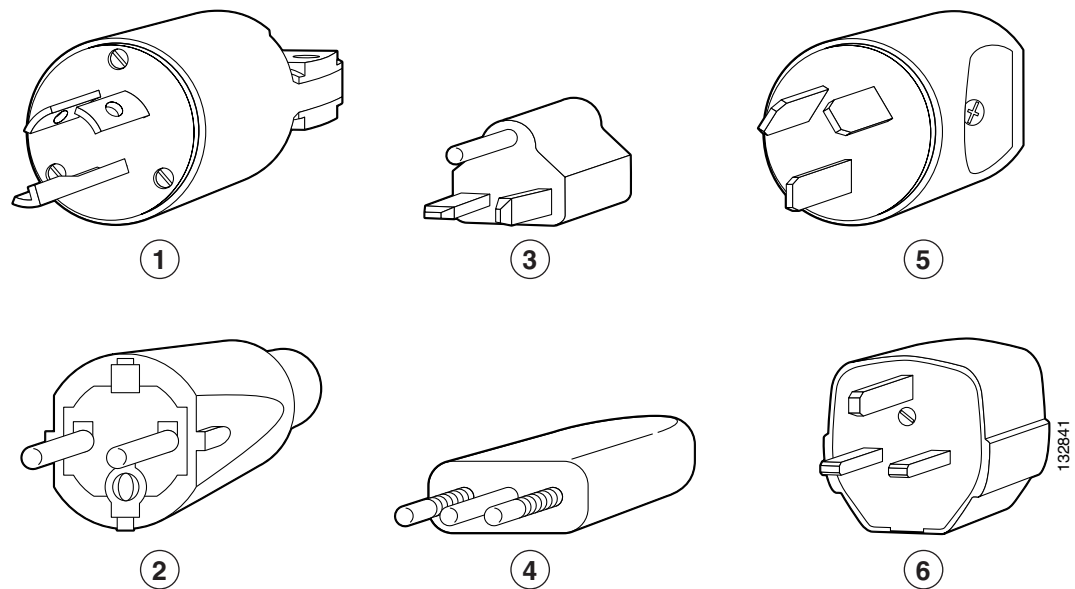

<b>1</b>	North American/Japanese plug, L6-20 20A	<b>4</b>	Italian plug, CEI 23-16/VII 10A
<b>2</b>	European plug, CEE 7/7 16A	<b>5</b>	Australian/Argentinean plug, AS 3112 10A
<b>3</b>	North American plug, NEMA 5-20P 20A	<b>6</b>	United Kingdom plug, BS 1363 13A

**Table 3-4 AC Power Cord Options**

<b>Label</b>	<b>Description</b>	<b>Plug (Facility End of Cord)</b>	<b>Receptacle (Router End of Cord)</b>	<b>Product Number</b>
North American	250 VAC, 60 Hz AC power cord	NEMA L6-20, 20A	IEC 320-C19	CAB-AC-6CK-TWLK
Japanese	100 VAC, 50/60 Hz AC power cord	NEMA L6-20, 20A	IEC 320-C19	CAB-DS-ACJ-TWLK
North American	120 VAC, 60 Hz AC power cord	NEMA 5-20P, 20A	IEC 320-C19	CAB-DS-120VAC
Australian	240 VAC, 50 Hz AC power cord	AS 312, 10A	IEC 320-C19	CAB-DS-ACA
Argentinean	220 VAC, 50 Hz AC power cord	AS 312, 10A	IEC 320-C19	CAB-DS-ACR
European	230 VAC, 50 Hz AC power cord	CEE 7/7, 16A	IEC 320-C19	CAB-DS-ACE
Italian	220 VAC, 50 Hz AC power cord	CEI 23-16/VII, 10A	IEC 320-C19	CAB-DS-ACI
United Kingdom	240 VAC, 50 Hz AC power cord	BS 1363, 13A	IEC 320-C19	CAB-DS-ACU

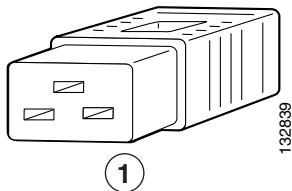
**Figure 3-23 AC Receptacle – Router End of AC Power Cord**

<b>1</b>	Appliance coupler, IEC320C-19 (16A/20A)		
----------	---	--	--

**Figure 3-24** Setting AC PEM Switch to the Off Position

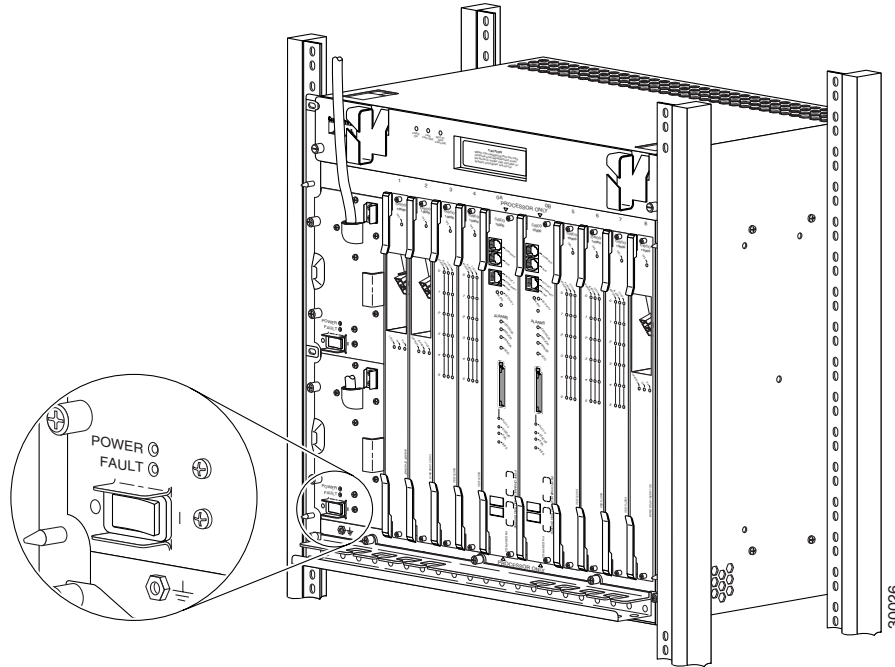

Use the following procedure to connect AC power to the PEM:

- 
- Step 1** Set the AC PEM switch (or switches) to the Off position ([Figure 3-24](#)).
  - Step 2** Connect the power cord from the PEM to the power cord that connects to the facility VAC input.

Figure 3-25 AC Power Cord Connectors in Strain Relief Devices

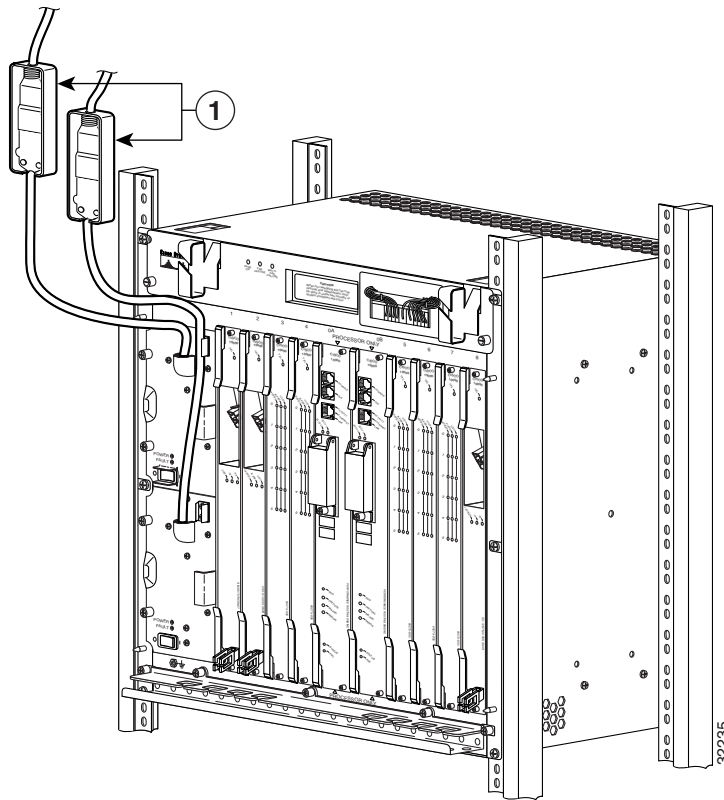

<b>1</b>	Power cord strain relief device
----------	---------------------------------

- Step 3** Set the AC power cord connectors in a cord strain relief device to prevent them from accidentally disconnecting (Figure 3-25).
- Step 4** Plug the power cord into the facility VAC input receptacle.
- Step 5** If you are connecting audio or visual alarm indicators to your system, go to the “[Connecting Alarm Indicators](#)” section on page 3-26.

If you are not connecting any alarm indicators, go to the “[Connecting a Video Terminal to the PRE Console Port](#)” section on page 3-30 to continue the installation.

## Connecting Alarm Indicators

The Cisco 10008 router provides relay contacts for optional (customer-supplied) audible or visual alarm indicators. Relay contacts are provided for three levels of severity:

- **Minor**—This is an informational alarm and does not affect the system operation.
- **Major**—An alarm condition that affects system operation and should be investigated as soon as possible.
- **Critical**—An alarm condition that affects system operation and requires immediate attention.

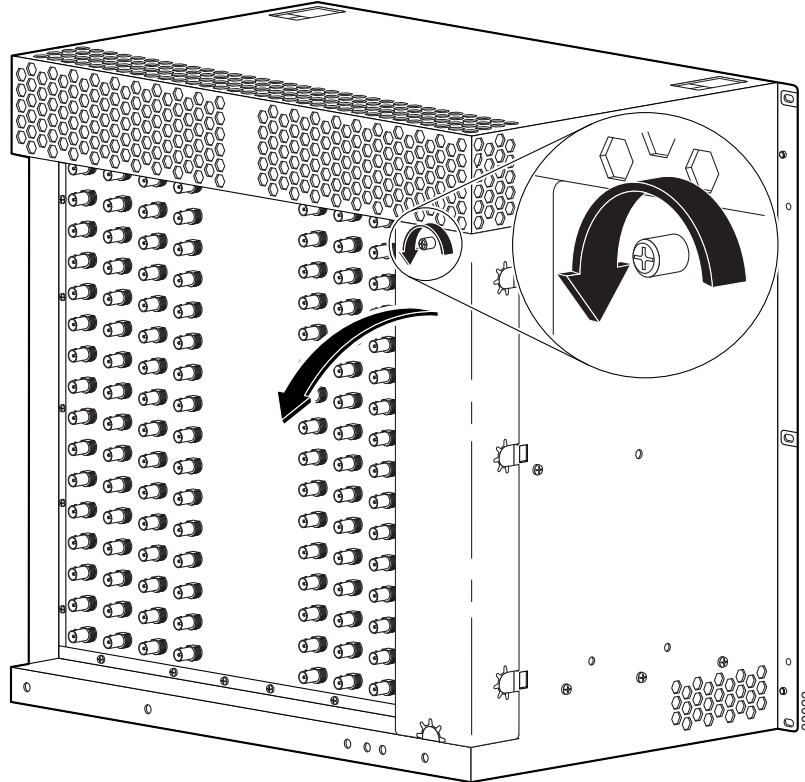
**Figure 3-26** Removing the Safety Cover

Use the following procedure to connect an alarm indicator to the system:

- 
- Step 1** Loosen the captive screw on the rear safety cover and tilt the cover back (Figure 3-26).

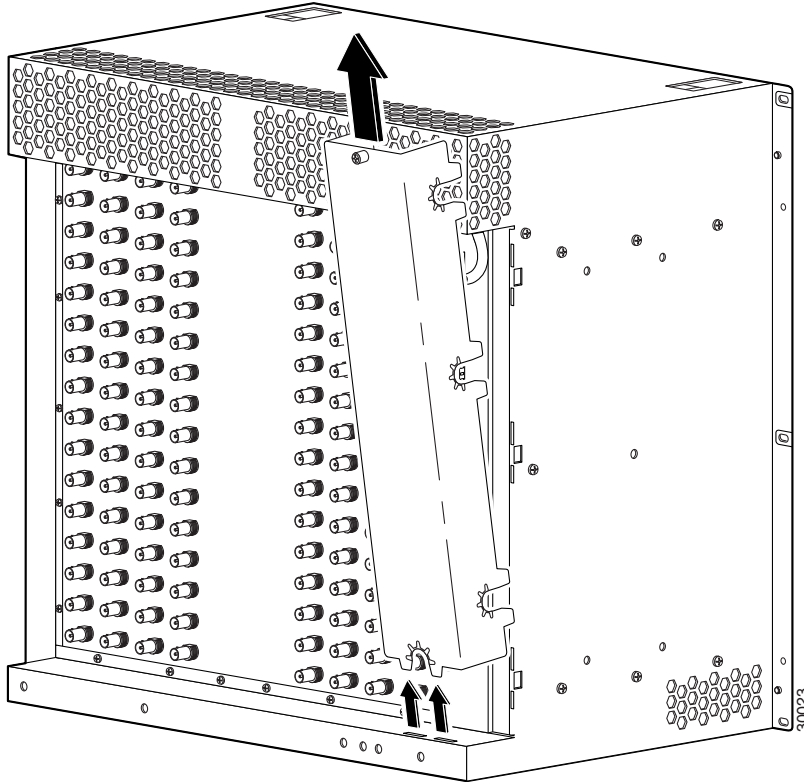
**Figure 3-27** Removing the Rear Cover

**Step 2** Remove the safety cover by lifting it up and out from the chassis (Figure 3-27).

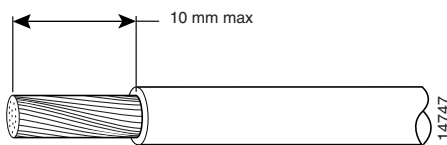
**Figure 3-28** Stripping Insulation

**Step 3** Strip not more than 0.4 inches (10 mm) of insulation off the ends of the alarm indicator wire (Figure 3-28).

**Step 4** Connect one set of alarm indicator wires to the alarm terminal block as follows (see Figure 3-29):

- Connect one lead to the common (COM) terminal.
- Connect the other lead to the normally closed (NC) or normally open (NO) terminal.

**Caution**

Figure 3-29 shows the wiring configuration for normally open (NO) alarm relays. If you are wiring the router in *series* with other equipment for the alarm indicators, use the normally closed (NC) terminals. If you are wiring the router in *parallel* with other equipment for the alarm indicators, use the NO terminals.

**Figure 3-29 Alarm Terminal Block Connections**

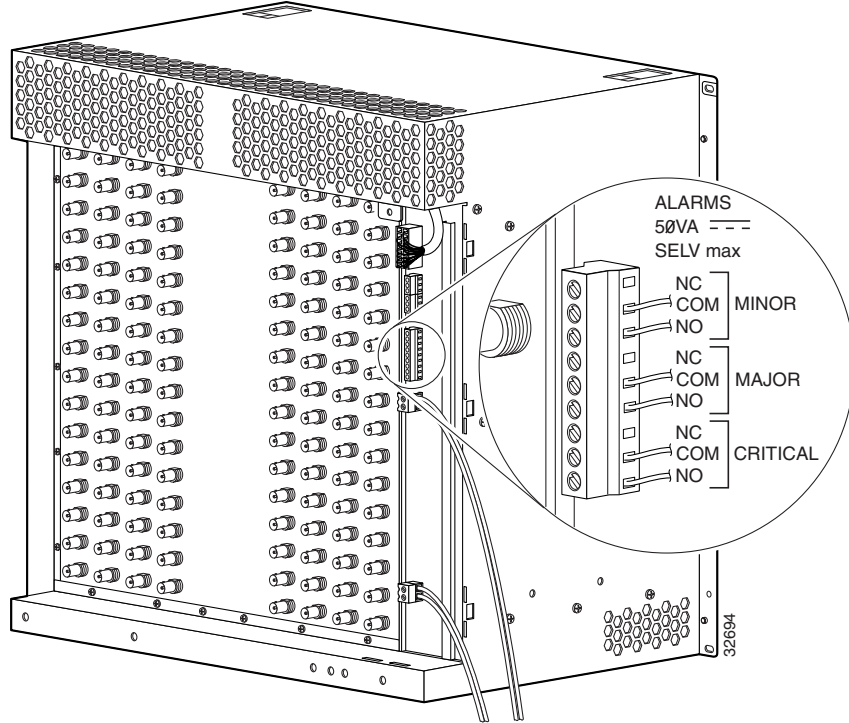

- Step 5** Repeat steps 3 and 4 for any remaining alarm indicators.
- Step 6** Secure the power cabling to the chassis by feeding a tie wrap through the slot on the side of the chassis and binding the wires (see blowout in [Figure 3-30](#)).
- Step 7** Replace the rear safety cover, making sure that the alarm indicator wires exit through the hole on the side of the cover ([Figure 3-30](#)).

**Figure 3-30 Alarm Indicator Wires Exiting Safety Cover**

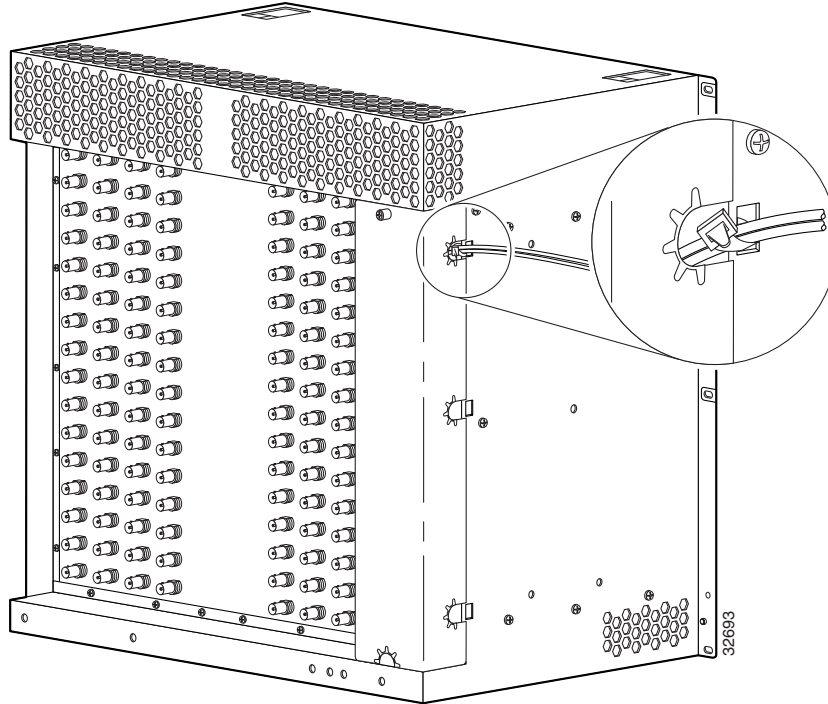

**Step 8** Go to the “[Connecting a Video Terminal to the PRE Console Port](#)” section on page 3-30 to continue the installation.

## Connecting a Video Terminal to the PRE Console Port

The Cisco 10008 router PRE module has an asynchronous serial (EIA/TIA-232) RJ-45 console port labeled CON on its front panel. You can connect this port to most types of video terminals through use of the console cable kit that is included with your Cisco 10008 router. The console cable kit contains:

- One RJ-45 to RJ-45 crossover cable
- One RJ-45 to DB-25 (female) adapter
- One RJ-45 to DB-9 (female) adapter

A crossover cable reverses pin connections from one end to the other. In other words, it connects pin 1 (at one end) to pin 8 (at the other end), pin 2 to pin 7, pin 3 to pin 6, and so on. You can identify a crossover cable by comparing the two modular ends of the cable. Hold the cable ends in your hand, side-by-side, with the tabs at the back. Ensure that the wire connected to the outside (left) pin of the left plug (pin 1) is the same color as the wire connected to the outside (right) pin of the right plug (pin 8).

Use the following procedure to connect a video terminal to the console port on a PRE module.



**Note**

Each PRE must have a console port connection (typically to a terminal server) if you are running a redundant configuration in the chassis.

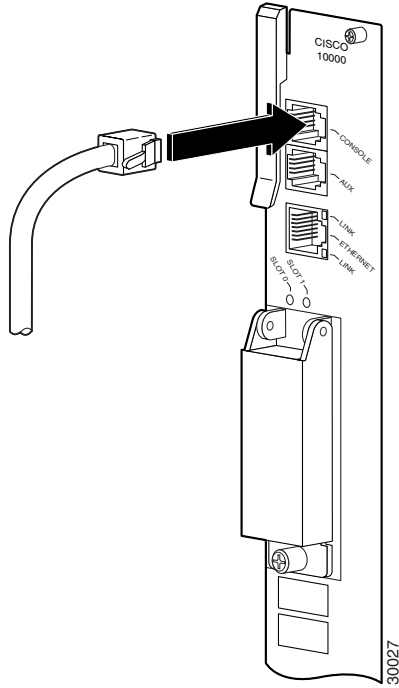

**Figure 3-31 Console Port Connection on the PRE Module**

- Step 1** Connect one end of the RJ-45 crossover cable to the serial RJ-45 port (CON) on the PRE module (Figure 3-31).
- Step 2** Run the cable up and through the cable management bracket and connect the other end of the RJ-45 crossover cable to the RJ-45 adapter (Figure 3-32). If your terminal is equipped with a:
- DB-25 serial connector, use the RJ-45-to-DB-25 adapter.
  - DB-9 serial connector, use the RJ-45-to-DB-9 adapter.

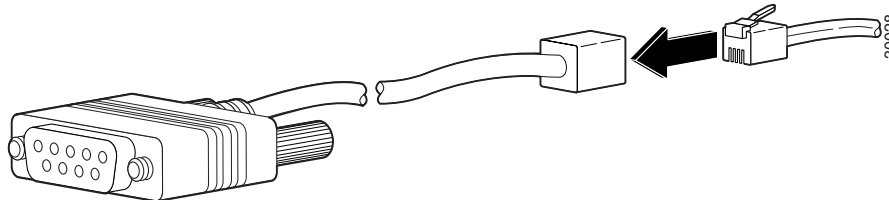
**Figure 3-32 Connecting an RJ-45-to-DB-9 Console Cable Adapter**

- Step 3** Connect the adapter to your video terminal to complete the cable connection.
- Step 4** Power on your video terminal.
- Step 5** Configure your video terminal to match the following default console port settings:
- 9600 baud
  - 8 data bits
  - No parity generation or checking
  - 1 stop bit
  - No flow control

- Step 6** Go to the “[Connecting Network Management and Signal System Cables](#)” section on page 3-32 to continue the installation.
- 

## Connecting Network Management and Signal System Cables

The Cisco 10008 router has connections to both the internal Ethernet management network and the external data network.

- The internal Ethernet management network connections are made through an Ethernet port on the front panel of the PRE module.
- The external data network connections are made through DS3 connectors on the router’s backplane, and through the front panel ports on several types of line cards.

Keep the following guidelines in mind when connecting external cables to the Cisco 10008 router:

- To reduce the chance of interference, avoid crossing high-power lines with any interface cables.
- Verify all cabling limitations (particularly distance) before powering on the system.

## Ethernet Network Management Cable Connections

The PRE module provides an Ethernet port to a LAN for a 10BASE-T or 100BASE-T connection for network management. Use the following procedures to connect the Cisco 10008 router to an Ethernet network.

**Note**

Each PRE must have an Ethernet port connection (typically to the same Ethernet hub) if you are running a redundant configuration in the chassis.

---

## Connecting to a 10BASE-T Ethernet Network

To make this connection, you need the following additional equipment (not included):

- An Ethernet hub (such as a Cisco Micro Hub)
- An Ethernet cable that meets the following specifications:
  - RJ-45 (male) to RJ-45 (male) straight-through cable
  - 100-ohm category 3, 4, or 5, no longer than 328 feet (100 meters)

You can identify a straight-through Ethernet cable either by using a cable tester or by making a visual inspection. To make a visual inspection, hold the two ends of a cable side by side, with the tab for each at the back.

- The wire connected to the left-most pin (pin 1) on one connector should be the same color as the wire connected to the left-most pin on the other connector.
- The same rule applies to pins 2 through 8 on each connector. The color of the wire attached to a pin on one connector should match the color of the wire attached to the corresponding pin on the other connector.

Follow these steps to connect the PRE to a 10BASE-T Ethernet LAN:

**Figure 3-33** Connecting 10BASE-T to Ethernet Port

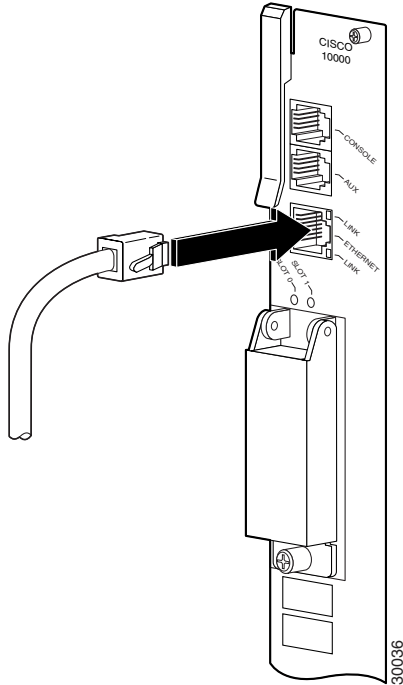

- 
- Step 1** Connect one end of the Ethernet cable to the RJ-45 port on the primary PRE, labeled ETH (Figure 3-33).
- Step 2** Run the cable up and through the cable management bracket and connect the other end of the Ethernet cable to any unoccupied port on the Ethernet hub.
- Step 3** Check the LNK (Link) LED on the PRE faceplate (next to the ETH) port.  
This LED lights (green) if the PRE is correctly connected to the 10BASE-T Ethernet LAN.
- 

## Connecting to a 100BASE-T Ethernet Network

To make this connection, you need the following additional equipment (not included):

- An Ethernet hub (such as a Cisco Micro Hub)
- An Ethernet UTP cable that meets the following specifications:
  - RJ-45 (male) to RJ-45 (male) straight-through cable.
  - 100-ohm category 5 cable not longer than 328 feet (100 meters). (Cisco Systems does not supply Category 5 UTP cables; these cables are available commercially.)

You can identify a straight-through Ethernet cable either by using a cable tester or by making a visual inspection. To make a visual inspection, hold the two ends of a cable side by side, with the tab for each at the back.

- The wire connected to the left-most pin (pin 1) on one connector should be the same color as the wire connected to the left-most pin on the other connector.
- The same rule applies to pins 2 through 8 on each connector. The color of the wire attached to a pin on one connector should match the color of the wire attached to the corresponding pin on the other connector.

**Caution**

If the Cisco 10008 router is used in an environment in which lightning-induced transients are likely to couple to the signal lines, use of shielded interconnection cables for the 100BASE-T ports is highly recommended. In addition, use of shielded interconnection cables for the 100BASE-T ports is required to meet Telcordia (formerly Bellcore) GR1089 CORE Section 4.5.9 and ETSI Section 5.2.2.2 (intrabuilding lightning surge).

The RJ-45 port on the PRE is configurable for 100-Mbps full-duplex or half-duplex operation (half-duplex is the default) and supports IEEE 802.3, Ethernet, and IEEE 802.3u interfaces compliant with 100BASE-T specifications.

Follow these steps to connect the PRE to a 100BASE-T Ethernet LAN:

**Figure 3-34** Connecting 100BASE-T to Ethernet Port

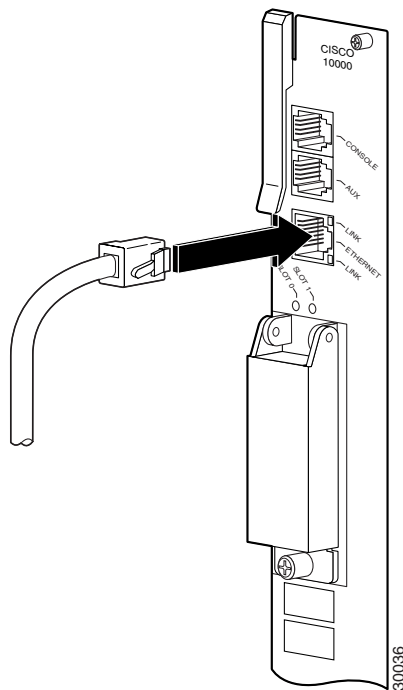

- Step 1** Connect one end of the Ethernet cable to the RJ-45 port on the primary PRE, labeled ETH (Figure 3-34).
- Step 2** Run the cable up and through the cable management bracket and connect the other end of the Ethernet cable to any unoccupied port on the Ethernet hub.
- Step 3** Check the LNK (Link) LED on the PRE (next to the ETH port).

This LED lights (green) if the PRE is correctly connected to the 10BASE-T Ethernet LAN.

## Auxiliary Modem Connection

This asynchronous EIA/TIA-232 serial port is used to connect a modem to the PRE for remote administrative access. Use the following procedure to connect the Cisco 10008 router to a modem.

**Figure 3-35** Connecting Modem Cable to Auxiliary Port

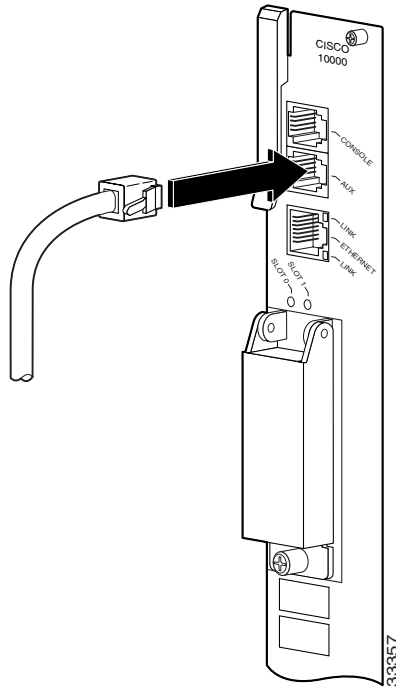

- 
- Step 1** Connect one end of the modem cable to the RJ-45 port on the primary PRE, labeled AUX (Figure 3-35).
- Step 2** Run the cable up and through the cable management bracket and connect the other end of the cable to your modem.
- 

## Data Network Cable Connections

For data network cable connection installation information, SFP and GBIC information, cable specifications and optical specifications, see the [Cisco 10000 Series Routers Line Card Hardware Installation Guide](#).

If you have completed all cable connections, go to the “Powering On the System” section on page 4-1, Chapter 4, “Starting and Configuring the Router.”





## CHAPTER 4

# Starting and Configuring the Router

---

This chapter provides information on powering on the system, basic file system information, and installation troubleshooting procedures.

- [Powering On the System, page 4-1](#)
- [Configuring the Cisco 10008 Router at Startup, page 4-2](#)
- [Formatting Flash Memory Cards and Disks, page 4-6](#)
- [Managing the File Systems, page 4-7](#)
- [Managing System Boot Parameters, page 4-9](#)
- [Predeployment Testing, page 4-11](#)
- [Troubleshooting Installation Problems, page 4-12](#)

## Powering On the System

When all of the interfaces are connected, perform a visual check of all connections and then check that:

- The ejector levers on each line card are in the locked position.
- All top and bottom line card retaining screws are tight.
- All network interface cables are connected to the line cards.
- The console terminal is turned on.
- A PCMCIA flash memory card installed in the PRE.

You are now ready to power on the system for the first time using the following procedure:

Figure 4-1 Cisco 10008 Router DC PEM Power Switches

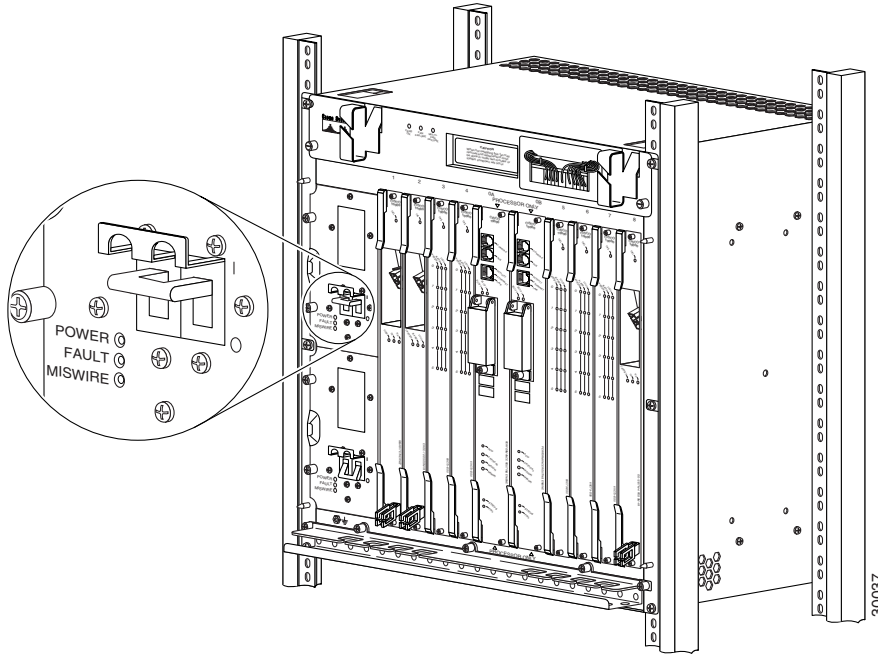

- 
- Step 1** Remove the tape from the building circuit breaker switches and set the circuit breaker to the On position. At the front of the chassis, set the circuit breakers on the PEM units to the on ( I ) position (Figure 4-1).
- a. The PEM Power LED lights (green), indicating that power is available to the chassis.  
If any Fault LEDs (such as Miswire or Single Fan Failure) light (yellow), see the [“Troubleshooting Installation Problems”](#) section on page 4-12.
  - b. The blower module Fan OK LED lights (green), indicating that all fans in the blower are operating properly.  
If any Fan Failure LEDs light (yellow), see the [“Troubleshooting Installation Problems”](#) section on page 4-12.
  - c. When the system boot is complete, the PRE begins to initialize the line cards. Go to the [“Configuring the Cisco 10008 Router at Startup”](#) section on page 4-2 to configure the line cards.
- 

## Configuring the Cisco 10008 Router at Startup

This section explains how to create a basic running configuration for your Cisco 10008 router using the Cisco 10008 setup facility or the Cisco IOS command line interface (CLI). For information on modifying the configuration after you create it, see the Cisco IOS configuration and command reference guides.

To configure a Cisco 10008 router from the console, you must connect a terminal or terminal server to the router's console port. To configure the Cisco 10008 router over your management Ethernet, you must have the router's IP address available.



## Startup Display

When you power on your Cisco 10008 router or execute the **reload** command, the console screen displays a message similar to the following:

```
Restricted Rights Legend
```

```
Use, duplication, or disclosure by the Government is
subject to restrictions as set forth in subparagraph
(c) of the Commercial Computer Software - Restricted
Rights clause at FAR sec. 52.227-19 and subparagraph
(c) (1) (ii) of the Rights in Technical Data and Computer
Software clause at DFARS sec. 252.227-7013.
```

```
    cisco Systems, Inc.
    170 West Tasman Drive
    San Jose, California 95134-1706
```

```
Cisco Internetwork Operating System Software
IOS (tm) 10008 Software (C10K-P6-M), Experimental Version 12.0(20000413:055718)
[20000413:010004 104]
Copyright (c) 1986-2000 by cisco Systems, Inc.
Compiled Thu 13-Apr-00 04:20 by chrel
Image text-base: 0x60008900, data-base: 0x60A6E000
```

```
cisco C10008 (CRE-RP) processor with 114688K/16384K bytes of memory.
Processor board ID 00018655341
R7000 CPU at 262Mhz, Implementation 39, Rev 1.0, 256KB L2, 2048KB L3 Cache
Unknown midplane, Version 1.0
```

```
Last reset from register reset
Toaster processor tmc0 is running.
Toaster processor tmcl is running.
1 Ethernet/IEEE 802.3 interface(s)
1 FastEthernet/IEEE 802.3 interface(s)
509K bytes of non-volatile configuration memory.
```

```
40960K bytes of ATA PCMCIA card at slot 0 (Sector size 512 bytes).
32768K bytes of Flash internal SIMM (Sector size 256KB).
```

```
Press RETURN to get started!
```

## Basic Configuration Using the Setup Facility

The first time you power on a Cisco 10008 router, the setup facility starts. You can also initiate the facility by running the **setup** command in privileged EXEC mode. This facility helps you enhance a default configuration that already exists on the Cisco 10008 router. The setup facility uses a question and answer sequence called the System Configuration Dialog to walk you through configuring the router.

You do not have to configure the interfaces immediately; however, you cannot enable the interfaces or connect them to any networks until you have configured them.



**Tip**

---

Basic configuration setup is often used as a quick way to achieve network connectivity, allowing you to retrieve a configuration file from a TFTP server.

---

## Using the System Configuration Dialog

Use the System Configuration Dialog to help you perform a basic configuration. Proceed through the dialog by answering questions and then pressing the Enter key. In most cases, you can get additional information by entering a question mark (?). Throughout the dialog, default values are shown in square brackets [ ].



### Tip

If you have experience using Cisco routers, consider configuring the router by using the procedure described in the [“Basic Configuration in Global Configuration Mode”](#) section on page 4-6.

To cancel the configuration dialog, press **Ctrl-C**, or you can let the dialog help you perform one of two configuration types:

- Basic configuration setup configures only enough connectivity for management of the system.
- Extended setup asks you to configure each interface and is not appropriate for configuring the Cisco 10008 router. For more information, see the [Cisco IOS Configuration Fundamentals Configuration Guide](#).

You can run the setup facility any time you are at the enable prompt (#) by entering the command **setup**.

## Basic System Configuration Procedure

Use the following procedure to perform a basic configuration using the System Configuration Dialog:

- 
- Step 1** The dialog starts by asking if you want to continue with the configuration dialog. Enter **Yes**. To return to the enable prompt, enter **No**.
- ```
--- System Configuration Dialog ---
Continue with configuration dialog? [yes/no]: yes
```
- Step 2** Enter **Yes** to perform a basic management setup. Enter **No** to perform an extended configuration setup.
- ```
Would you like to enter basic management setup? [yes/no]: yes
```
- Step 3** Specify a hostname. The hostname becomes part of the Cisco IOS prompt.
- ```
Enter host name [Router]: my-router
```
- Step 4** Specify a secret password. It appears in encrypted form in the configuration file.
- ```
Enter enable secret: my_secret
```
- Step 5** Specify the enable password. It is used if you did not assign a secret one.
- ```
Enter enable password: my_password
```
- Step 6** Specify the password to use for telnet sessions.
- ```
Enter virtual terminal password: my_vt
```
- Step 7** At the configure system management prompt, enter **No**.
- ```
Configure System Management? [yes/no]: no
```
- Step 8** If you want to access the router using SNMP, enter **Yes** at the prompt:
- ```
Configure SNMP Network Management? [yes]: yes
```
- Step 9** Specify an SNMP community string.

```
Community string [public]: public
```

After you respond to the SNMP questions, the setup script lists the interfaces. For example:

Interface	IP-Address	OK?	Method	Status	Protocol
Ethernet0/0/0	unassigned	YES	unset	up	up
FastEthernet0/0/0	unassigned	NO	unset	up	up

Interfaces that are not okay (OK? = NO) do not have a valid configuration.

- Step 10** To achieve network connectivity, enter the interface for the FastEthernet interface.

```
Enter interface name used to connect to the management network from the above interface
summary: FastEthernet0/0/0
```

- Step 11** Accept the default value for the type of connector. RJ-45 is the only connector that can be used on the Cisco 10008 router Ethernet port.

```
Configuring interface FastEthernet0/0/0:
Use the 100 Base-TX (RJ-45) connector? [yes]: yes
```

- Step 12** Configure both the Cisco 10008 router and the remote device to use the same mode.

```
Operate in full-duplex mode? [no]: no
```

- Step 13** You must enter the IP address to achieve network connectivity.

```
Configure IP on this interface? [yes]: yes
```

- Step 14** Specify the IP address.

```
IP address for this interface: 172.27.48.209
```

- Step 15** Enter the subnet mask for the IP address.

```
Subnet mask for this interface [255.255.0.0] : 255.255.0.0
```

The system displays the information you entered as well as several default commands, such as the **no shutdown** command. For example:

```
The following configuration command script was created:
hostname c10008
enable secret 5 $1$uror$EFU0hKOBQXhk975qKFZ1L0
enable password lab
line vty 0 4
password lab
no snmp-server
!
no ip routing
!
interface FastEthernet0/0/0
no shutdown
media-type 100BaseX
half-duplex
ip address 172.27.48.209 255.255.0.0
!
end
```

- Step 16** The setup script concludes by giving you the choice to exit without saving, start the setup script, or save the configuration file:

```
[0] Go to the IOS command prompt without saving this config.
[1] Return back to the setup without saving this config.
[2] Save this configuration to nvram and exit.
```

Enter your selection [2]:

- Step 17** After you complete the configuration dialog, enter global configuration mode and enable ip routing by entering the **ip routing** command:

```
router(config)#ip routing
```

## Basic Configuration in Global Configuration Mode

The following command sequence allows you to perform a configuration similar to that generated by the **setup** command.

```
Router>configure terminal
Router(config)#hostname c10008
Router(config)#enable secret my_router
Router(config)#enable password my_rtr
Router(config)#snmp-server community public
Router(config)#ip routing
Router(config)#interface FastEthernet0/0/0
Router(config-if)#no shutdown
Router(config-if)#media-type 100BaseX
Router(config-if)#half-duplex
Router(config-if)#ip address 3.5.3.45 255.255.0.0
Router#copy running-config startup-config
```

You can now configure the line cards. For specific information on system and interface configuration, see the *Cisco 10000 Series Router Line Card Configuration Guide*.

## Formatting Flash Memory Cards and Disks

The Flash memory disk card that shipped with your router contains the default Cisco IOS image for booting your router. This section explains how to format an ATA flash disk, modify its contents, or resolve a problem with the card.



### Caution

The formatting procedure erases all information on a Flash memory disks or cards.

Flash memory ATA disks and Flash memory cards use similar commands. The primary syntax change is that *disk0:* or *disk1:* refers to Flash memory ATA disks while *slot0:* or *slot1:* refers to Flash memory cards.

Use the following procedure to format a Flash memory disk:

- Step 1** To format a Flash memory disk, you should be in privileged EXEC mode.
- Step 2** Ensure there is a Flash memory disk in PCMCIA slot 0 or slot 1 of the PRE.

- Step 3** Enter the **format disk*n*:** command at the privileged EXEC mode prompt to format the disk. The following example shows the display after you enter the **format disk0:** command:

```
Router# format disk0:
All sectors will be erased, proceed? [confirm]
Enter volume id (up to 30 characters): MyNewdisk
Formatting sector 1
Format device slot0 completed
Router#
```

The Flash memory disk is now ready for use.

## Managing the File Systems

This section describes the file systems used on the Cisco 10008 series router and provides procedures for performing the following basic file system tasks:

- [File Systems, page 4-7](#)
- [Copying the Startup Configuration to the Running Configuration, page 4-8](#)
- [Managing Configuration Files Larger than NVRAM, page 4-8](#)

## File Systems

The Cisco 10008 series router includes the file systems described in [Table 4-1](#).

**Table 4-1** Cisco 10008 Series Router Principal File Systems

File System	CLI Name	Description
Bootflash Secondary bootflash	bootflash: sec-bootflash:	Stores image and dump files.
NVRAM Secondary NVRAM	nvram: sec-nvram:	Typically stores the system default configuration file and startup configuration file.
System	system:	Stores the running configuration and other system files.
Disk 0 Disk 1 Slot 0 Slot 1 Secondary Disk 0 Secondary Disk 1 Secondary Slot 0 Secondary Slot 1	disk0: disk1: slot0: slot1: sec-disk0: sec-disk1: sec-slot0: sec-slot1:	Disk refers to an ATA Flash disk (48 or 128 MB). Slot refers to a Flash memory card (8, 16, or 20 MB). 0 refers to the left slot on the PRE. 1 refers to the right slot on the PRE. Secondary refers to the secondary PRE in a redundant system.
FTP TFTP RCP	ftp: tftp: rcp:	Protocols used for accessing files that are stored remotely.

Flash memory disks and the smaller Flash memory cards use similar commands. The primary syntax change is that disk0: or disk1: refers to Flash memory disks, and slot0: or slot1: refers to Flash memory cards.

You can use the privileged EXEC commands **dir**, **del**, and **copy** to manage the contents of the file systems. You can also use the commands **mkdir** and **rmdir** to create and remove directories on Flash disks. You cannot use the commands **squeeze** and **undelete** on Flash disks. For more information, refer to the [Cisco IOS Configuration Fundamentals Configuration Guide](#).

## Copying the Startup Configuration to the Running Configuration

Use the **copy startup-config running-config** command to copy the startup configuration file on NVRAM to the running configuration. If your startup configuration file is approaching the NVRAM limit of 512 KB, you must either compress it or relocate it as described in the following sections.



**Tip**

If your configuration file is large, run the **copy startup-config running-config** command during off-peak hours. This command might slow down traffic for several minutes while the system is merging the starting and the running configurations.

## Managing Configuration Files Larger than NVRAM

To maintain a configuration file that exceeds the size of NVRAM (512 KB), you must compress or relocate the configuration file. This section provides an example of each approach. For more information, refer to the [Cisco IOS Configuration Fundamentals Configuration Guide](#).

### Compressing the Configuration File

Use the **service compress-config** global configuration command to compress the configuration file for storage in NVRAM. A compressed file can take several minutes longer to load than an uncompressed file.

To compress configuration files, use the following commands, beginning in global configuration mode:

**Step 1** Specify that the configuration file is to be compressed.

```
Router(config)# service compress-config
```

**Step 2** Exit global configuration mode.

```
Router(config)# end
```

**Step 3** Use one of the copy commands to copy the new configuration. For example:

```
Router# copy running-config startup-config
```

```
Building configuration...
```

```
Compressing configuration from 129648 bytes to 11077 bytes
```

```
[OK]
```

To cancel the compression feature, use the **no service compress-config** command.



**Note**

If you try to load a configuration that is more than three times larger than the NVRAM size, the following error message appears: [buffer overflow—file-size/buffer-size bytes].

## Relocating the Configuration to a Flash Disk

To run the startup configuration off a Flash disk, use the following commands beginning in privileged EXEC mode:

- 
- Step 1** Copy the current startup configuration to a new location. In the following example, the configuration file is copied from a TFTP server to a Flash disk in slot 0:
- ```
Router# copy tftp://172.16.2.15/example-config disk0:router-config
```
- Step 2** Enter global configuration mode.
- ```
Router# configure terminal
Router(config)#
```
- Step 3** The buffer that holds the configuration file is usually the size of NVRAM (512 KB). Larger configurations need larger buffers. Change the size of the buffer that holds the configuration commands.
- ```
Router(config)# boot buffersize 1024000
```
- Step 4** Specify that the startup configuration file is located in Flash memory by setting the CONFIG\_FILE variable. In the following example, the system is told that the boot configuration file is in slot 0 and the filename is *router-config*:
- ```
Router(config)# boot config disk0:router-config
```
- Step 5** Exit global configuration mode.
- ```
end
```
- Step 6** When you finish changing the running-configuration, save the new configuration.
- ```
Router# copy running-config startup-config
```
- 

As a result of this procedure, when you reboot the Cisco 10000 series router, it loads the configuration file that resides on Flash disk 0.

## Managing System Boot Parameters

This section tells you how to use Cisco IOS to modify PRE boot parameters by changing the configuration register settings.

During the boot process, the system reads a configuration register that defines certain system parameters. The software configuration register is a 16-bit register in NVRAM used to define such characteristics as

- The source of the Cisco IOS software image required to run the router
- Whether the system software should ignore the contents of NVRAM
- The behavior of the Break function

By modifying the boot parameters, you can customize your Cisco 10000 series router. For example, a common configuration register setting in some lab environments is 0x2100. Using this setting, the system boots to the ROM monitor prompt, where a technician can load a specific image by entering the **boot** command at the rommon prompt. (For more information, see the [Cisco IOS Configuration Fundamentals Configuration Guide](#).)

## Changing the Configuration Register Settings

To change the configuration register settings while you are running system software, perform the following steps:

- Step 1** From global configuration mode, enter the **config-register** *value* command to set the contents of the software configuration register; *value* is a hexadecimal number preceded by 0x. For example:

```
Router(config)# config-register 0x2100
```

Consult the hexadecimal column in [Table 4-2](#) for the possible settings to enter as the 4-bit *value* parameter.

- Step 2** Exit global configuration mode by pressing **Ctrl-Z**.

```
Router(config)# Ctrl-Z
Router#
```

The new contents of the software configuration register are saved to NVRAM. These new settings do not take effect until you reload the system or reboot the router.

- Step 3** To display the new software configuration register setting, issue the **show version** command.

```
Router# show version
.
.
.
#Configuration register is 0x141 (will be 0x2100 at next reload)
```

- Step 4** Save the configuration file to preserve the new software configuration register settings.

```
Router# copy running-config startup-config
```

- Step 5** Reboot the router.

The software configuration register setting takes affect only after you reload the system. This happens when you issue the **reload** command from the console or reboot the router.

## Configuration Register Settings

[Table 4-2](#) summarizes the modifications that you can make to the software configuration register. For detailed information, refer to the [Cisco IOS Configuration Fundamentals Command Reference](#).



### Note

The factory default value for the software configuration register is 0x2102. This value is a combination of the following: binary bit 8 = 0x0100, bits 00 through 03 = 0x0002, and bit 13 = 2000.



**Table 4-2** Definition of Bits in the Software Configuration Register

Bit No.	Hex Value	Meaning/Function
00 to 03	0x0000 to 0x000F	Defines the source of a default Cisco IOS software image required to run the router: <ul style="list-style-type: none"> <li>• 00—At power-on, the system remains at the ROM monitor prompt (<code>rommon&gt;</code>), awaiting a user command to boot the system manually by means of the <code>rommon boot</code> command.</li> <li>• 01—At power-on, the system automatically boots the first system image found in the Flash memory single inline memory module (SIMM) on the PRE.</li> <li>• 02 to 0F—At power-on, the system automatically boots from a default Cisco IOS software image stored on a TFTP server in the network. For this setting, the Fast Ethernet port on the PRE must be configured and operational. This setting also enables boot system commands that override the default filename.</li> </ul>
06	0x0040	Causes system software to ignore the contents of NVRAM.
07	0x0080	Enable the original equipment manufacturer (OEM) bit.
08	0x0100	The Break function is disabled after 30 seconds.
09	0x0200	Not used.
10	0x0400	Broadcast based on 0.0.0.0 IP address.
11 and 12	0x0800 to 0x1000	Defines the console baud rate (the default setting is 9600 baud).
13	0x2000	Boots an image from the Flash SIMM.
14	0x4000	Broadcast using the subnet broadcast address.
15	0x8000	Enables diagnostic messages and ignores the contents of NVRAM.

## Predeployment Testing

Laboratory testing is a prerequisite for new equipment deployment. The aim of the testing is to certify the product for use in the network.

In the lab, the product is typically evaluated to

- Verify its interoperability with other network connected equipment
- Verify the performance and stability of a platform
- Test software services and features during simulated operation
- Verify that the product is NEBS compliant

Labs have a certification plan for measuring product stability and interoperability. After the platform demonstrates that it can pass the certification plan, it is deployed.

During performance testing, lab personnel:

- Refer to vendor documentation to make sure that the product meets vendor benchmarks.
- Often have specialized tools for testing, and might test the functionality in cooperation with customers who are interested in using the product.

# Troubleshooting Installation Problems

This section contains general troubleshooting information to help you solve any problems you might encounter during the installation of the system. For any problems not covered in this section and for more detailed troubleshooting information, see the *Cisco 10000 Series Router Troubleshooting Guide*. For troubleshooting information specific to line cards, see the *Cisco 10000 Series Routers Line Card Hardware Installation Guide*.

The following information is in this section:

- [General Troubleshooting Tips, page 4-12](#)
- [Troubleshooting Ethernet Connections, page 4-13](#)
- [Troubleshooting the Console Port Serial Connection, page 4-14](#)

## General Troubleshooting Tips

All Cisco 10008 FRUs are hot-swappable. Procedures for removing and replacing the FRUs can be found in [Chapter 5, “Maintaining the Cisco 10008 Router.”](#)

[Table 4-3](#) lists general FRU fault symptoms and recommendations.

**Table 4-3**      **General Troubleshooting Tips**

Symptom	Steps to Take
System fails to power on	Check that: <ul style="list-style-type: none"> <li>• All power cords are properly connected to the Cisco 10008 router and at the power connection end.</li> <li>• The PEM power switches are in the On position.               <ul style="list-style-type: none"> <li>– For DC PEMs, the POWER LED should be on (green).</li> </ul> </li> <li>• The blower module is fully inserted (FANS OK LED is on (green)).</li> </ul>
System fails to boot up properly	If the system has power, check the FAIL LED on the PRE and any information on the alphanumeric display. If the FAIL LED is on, see the <i>Cisco 10000 Series Router Troubleshooting Guide</i> .
DC PEM problem	<ul style="list-style-type: none"> <li>• If the FAULT LED is on, see the <i>Cisco 10000 Series Router Troubleshooting Guide</i>.</li> <li>• If the MISWIRE LED is on, the –48V and return (RTN) wires are reversed. Power off the PEM and reconnect the wires correctly (see the <a href="#">“Connecting DC Power to the Cisco 10008 Router”</a> section on <a href="#">page 3-17</a>).</li> </ul>
System experiences a critical alarm (Critical LED on the PRE is on)	Enter the <b>show facility-alarm status</b> command at the console.
System experiences a major alarm (Major LED on the PRE is on)	Enter the <b>show facility-alarm status</b> command at the console.
System experiences a minor alarm (Minor LED on the PRE is on)	Enter the <b>show facility-alarm status</b> command at the console.

**Table 4-3** General Troubleshooting Tips (continued)

Symptom	Steps to Take
You cannot establish a console or Telnet connection to the system.	For information about troubleshooting Ethernet connections, see the <a href="#">“Troubleshooting Ethernet Connections”</a> section on page 4-13. For information about troubleshooting the console port serial connections, see the <a href="#">“Troubleshooting the Console Port Serial Connection”</a> section on page 4-14.
Fan Failure	Perform the following if a FAN FAILURE LED lights: <ul style="list-style-type: none"> <li>• Reseat the blower module (see the <a href="#">“Replacing the Blower Module”</a> section on page 5-10).</li> <li>• Remove the rear safety cover and be sure that the blower module cable is connected securely (see the <a href="#">“Replacing the Blower Module”</a> section on page 5-10).</li> </ul>
System overheats	This may be due to a failure in the blower module (see Fan Failure above), insufficient ventilation, or high ambient temperature. See the <i>Cisco 10000 Series Router Troubleshooting Guide</i> for additional information.

## Troubleshooting Ethernet Connections

If an Ethernet connection to your Cisco 10008 router fails to work properly, and the corresponding LNK (Link) LED is not on, check for the following problems:

- Visually check that an Ethernet cable is connected to the correct Ethernet port on the PRE, and that the other end of the cable is connected to an Ethernet hub that is powered on and functioning properly.
- Check to see if you are using the correct type of cable. The cable must meet the specifications given in the [“Connecting to a 10BASE-T Ethernet Network”](#) section on page 3-32.
- The cable might be bad or broken. Replace the cable with a known, reliable straight-through Ethernet cable, checking to be sure the LNK LED comes on (green).
  - If the LNK LED is still off, it is possible that the Ethernet port might be functioning properly, but the LED is not working. Check the Ethernet port (by trying to ping over it, for example) to determine if the problem is due to a bad LED or if the Ethernet link is bad.
- Make sure the PRE has booted up properly as follows:
  - The Status LED should be on (green).
  - If the Fail LED is on (yellow), see the *Cisco 10000 Series Router Troubleshooting Guide* for troubleshooting information.
- Check the hub:
  - Is the cable connected into the correct hub port (for example, the hub LED is on, but the LNK LED on the PRE is not on).
  - Be sure that the cable is not connected to an uplink port.

- If the LNK LED is on (green), but the Ethernet port does not seem to be working properly, make sure that the port in question is configured properly and is not administratively shut down. If you have a working console connection, perform the following steps:

- At the router prompt, enter **show int fast0/0/0**. If the port is administratively down, enter these commands to enable it:

```
switch> configure terminal
Enter configuration commands, one per line. End with CNTL/Z.
router(config-if)# int fast0/0/0
router(config-if)# no shut
router(config-if)# exit
router(config)# exit
router#
```

- Check that the Ethernet port in question has a valid IP address assigned to it.

For more information about configuring Ethernet ports, see the [Cisco 10000 Series Router Line Card Configuration Guide](#).

If the cable, connections, power, and configuration all check out, and you still cannot connect to the Ethernet port on the module, you probably need to replace the PRE. Contact the Cisco TAC for further assistance.

## Troubleshooting the Console Port Serial Connection

If the terminal connected to the Cisco 10008 console port appears frozen or fails to work properly, check for the following problems:

- Check the console cable and make sure it is properly connected to the correct console port on the PRE, and to your equipment at the other end.
- Verify that you are using the proper type of cable and adapter. For additional information about cable pinouts, see the [“Connecting a Video Terminal to the PRE Console Port”](#) section on page 3-30.
- To be sure the cable is not defective or broken, replace the cable with another high quality cable if possible.
- Check that your terminal equipment is working properly and configured with the correct settings for the console port. The default console port settings are:
  - 9600 baud
  - 8 data bits
  - 1 stop bit
  - No parity
  - No flow control
- Check the LEDs on the PRE to make sure that it is powered on properly.
- If the cable, connections, power, and terminal settings are all acceptable and you still cannot connect to the console port on the module, you probably need to replace the PRE. Contact the Cisco TAC for further assistance.



# CHAPTER 5

## Maintaining the Cisco 10008 Router

---

The Cisco 10008 router is configured to your order and ready for installation when it arrives. After you install the system, you may have to perform specific maintenance procedures to ensure the router is operating properly. These procedures can include routine maintenance such as replacing the filter, upgrading system components, or replacing components with field replaceable units (FRUs). This chapter contains the information necessary to perform that maintenance for the Cisco 10008 router.

**Note**

---

Detailed, up-to-date instructions are also shipped with all FRUs and upgrade kits.

---

System components fall into two categories:

- hot-swappable components that do not require you to power off the system before replacing them
- those components that do require you to power off the system before you replace them.

For example, all line cards are hot-swappable and can be replaced without powering off the system, but you must power off the system before replacing a single power entry module (PEM) or a single Performance Routing Engine (PRE).

**Note**

---

To prevent alarms from activating, you must administratively shut down a line card before hot swapping it.

---

This chapter contains the following removal and installation information:

- [Front Cover Procedures, page 5-4](#)
- [Replacing the Air Filter, page 5-7](#)
- [Replacing the Blower Module, page 5-10](#)
- [Installing Power Entry Modules, page 5-12](#)
- [Removing and Replacing the PRE, page 5-36](#)
- [Removing and Installing DIMMS, page 5-47](#)

For information on removing and installing line cards, see the *Cisco 10000 Series Routers Line Card Hardware Installation Guide*.

Read [Chapter 2, “Preparing for Installation,”](#) and check the safety information in [Chapter 3, “Installing the Cisco 10008 Router”](#) before beginning any of the following procedures. Also see the *Regulatory Compliance and Safety Information for the Cisco 10000 Series Routers* document.



## Situational Analysis

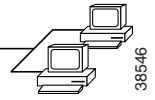

38546

### Spare Parts

Service providers usually draw on their own experience with similar equipment as they try to determine the number of spare parts of a given item to keep on hand. In developing a strategy for spare parts, the service providers must

- Evaluate the criticality of the equipment.
- Estimate the mean time between failures, a key component of any spares strategy.
- Calculate the number of production routers (and associated components) they need to have on hand. For example, if they have the critical mass to shift capacity to other locations or other devices, they may be able to carry fewer spares.

Service providers may also subscribe to services that supply them with replacement parts, sometimes with turnaround times as short as 4 hours.

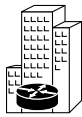

## Situational Analysis

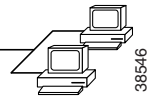

38546

### Redundancy

Service providers trying to decide on the level of redundancy appropriate for their operations must examine their business models. The service provider invests more heavily in high network reliability if the business model

- Calls for protected services
- Provides customer service-level agreements
- Accommodates customers that require a high degree of reliability
- Emphasizes overall reliability as opposed to cost

In addition, the service provider discusses the situation with the supplier to identify those software and hardware features likely to experience the most stress and thus to have the shortest mean time between failures. The point is to determine, not just whether or not redundancy is to be used, but also the quantity to be used (1:1, 2:1, or greater).

Some service providers have redundant chassis, but not redundant routing engines. This approach gives them increased flexibility, so that they can provide reliable service and accommodate a growing number of customers. Customers requiring the highest levels of network reliability and availability often add redundancy by connecting to two different service providers.

## Required Maintenance Tools

The only tools required to perform the maintenance procedures described in this chapter are:

- A Number 2 Phillips screwdriver
- A flat-blade screwdriver
- An electrostatic discharge (ESD) grounding strap

## Shutting Down the System

Although most components in the Cisco 10008 router are hot-swappable, you may have to shut down the system under certain circumstances. Use the following procedure to shut down the system:

- 
- Step 1** Notify appropriate personnel that you plan to shut down the system and that the shutdown results in total loss of service. *Appropriate personnel* includes the regional alarm or network monitoring center, central office personnel, and key customers.
- Step 2** Before you shut down the router, use the **copy** command to save any configuration changes to NVRAM, and also, if you wish, to a Flash disk (see “[Relocating the Configuration to a Flash Disk](#)” section on [page 4-9](#) for instructions about using the **copy** command).
- Step 3** Power down the system by setting the power switch on all PEMs to the off (0) position (your system can be configured with one or two PEMs).
- 

## Backing Up the PCMCIA Card

Cisco recommends that you create a duplicate PCMCIA card that contains the current boot software image and the current software configuration. You can use the backup card to quickly recover from a major system failure. You can also use a backup card to load a new PRE module and avoid the time-consuming reconfiguration process. For instructions to create a backup flash disk, see “[Relocating the Configuration to a Flash Disk](#)” section on [page 4-9](#).

## Removing and Replacing Field-Replaceable Units

This section contains the procedures to remove and replace all of the field replaceable units (FRUs) for the Cisco 10008 router. Before beginning any FRU procedure, be sure you are familiar with the safety precautions outlined in [Chapter 2](#), “[Preparing for Installation](#).”

**Note**

The illustrations in this guide depict the original Cisco 10008 chassis. Your chassis may have slight differences, but the procedures are the same.

## Front Cover Procedures

The original Cisco 10008 router is equipped with a plastic front cover that ensures proper air flow through the system and protects the cables and connectors from damage. The following procedures describe how to remove and replace the front cover.



**Note**

Your router may not have a front cover. Only the original Cisco 10008 chassis was equipped with a plastic front cover. Later redesigned models do not use a front cover.

### Removing the Front Cover

Use the following procedure to remove the front cover from the chassis:

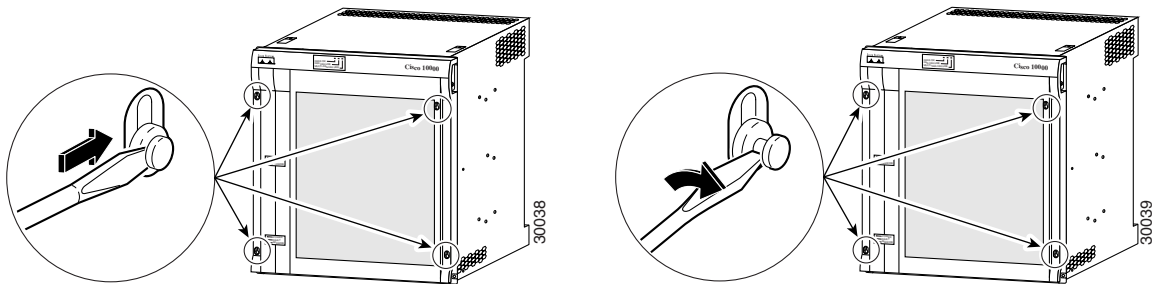
**Figure 5-1** *Unlocking the Bezel Plugs*



- Step 1** Unlock a bezel plug by wedging the tip of a flat-blade screwdriver between the top and bottom sections of the plug, and then rotating the screwdriver to loosen the top portion of the plug (Figure 5-1). Repeat this procedure for all four bezel plugs, and then remove the plugs.



**Figure 5-2** Removing the Front Cover

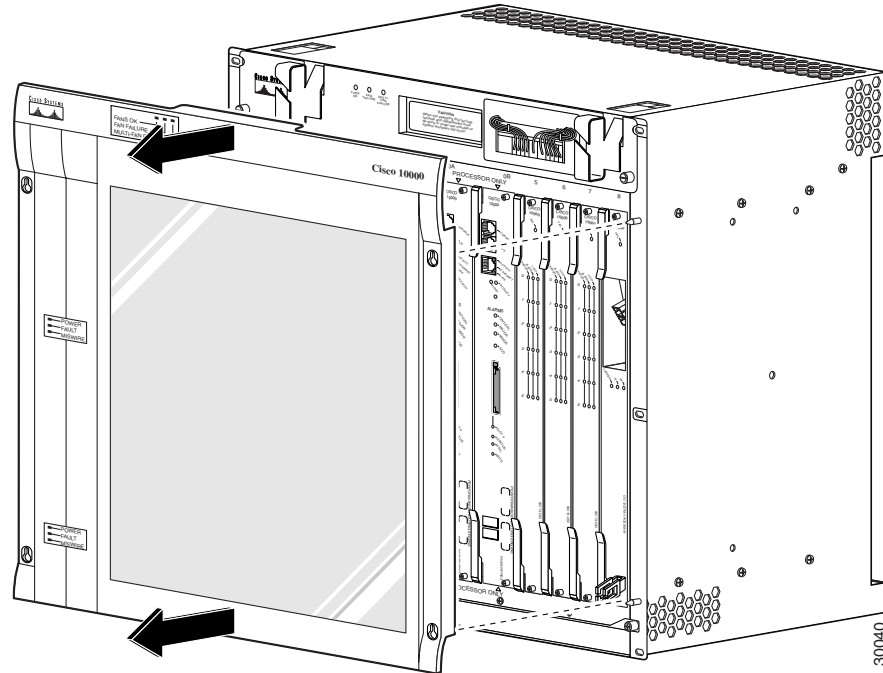

**Step 2** Remove the cover by lifting it up slightly and then pulling it toward you (Figure 5-2).

---

## Replacing the Front Cover

Use the following procedure to replace the front cover on the chassis:

**Figure 5-3** Attaching the Cover to the Chassis

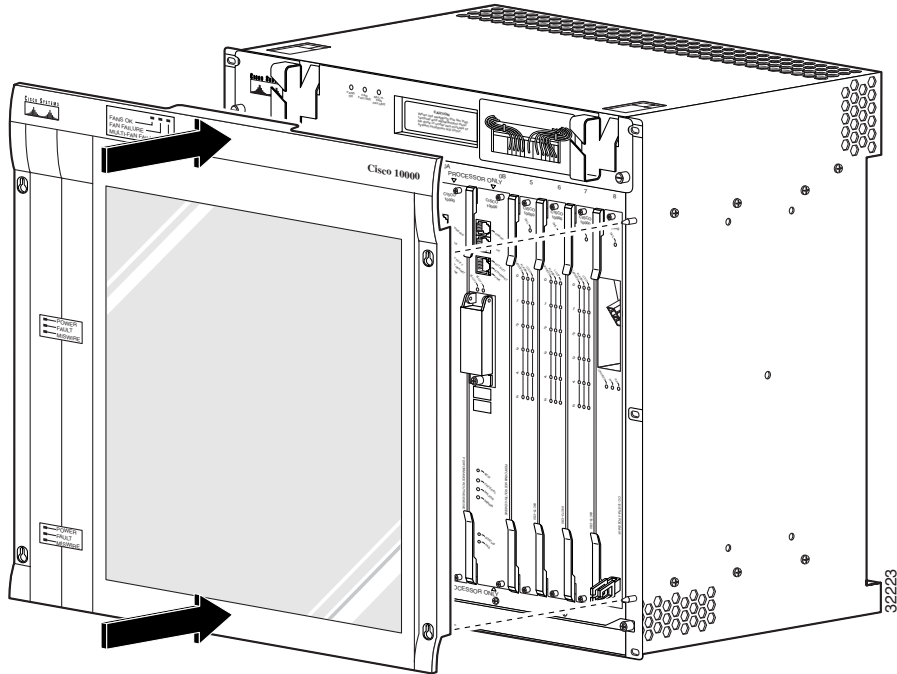

- Step 1** Slide the cover onto the four corner posts of the chassis and then push down so that the posts are seated in the grooves above the cover holes (Figure 5-3).

**Figure 5-4** Inserting Bezel Plugs

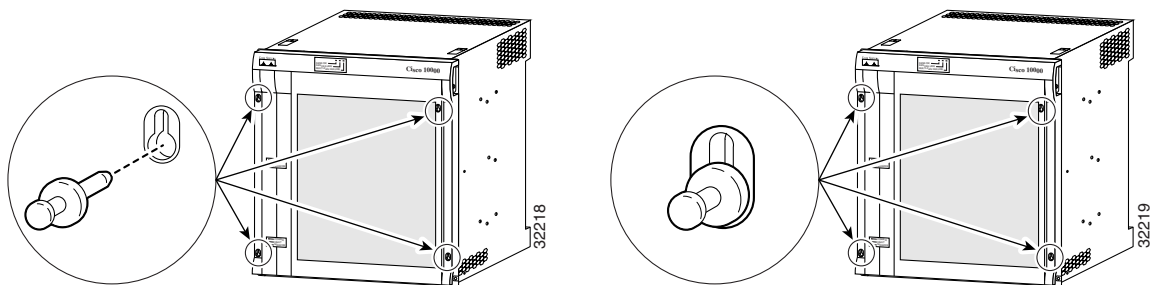

- Step 2** Insert a bezel plug into each hole below the corner posts and press in the top of each bezel plug to secure the front cover to the chassis (Figure 5-4).

## Replacing the Air Filter

If the air filter is dirty or clogged, the blower module could have a problem providing sufficient cooling air flow throughout the chassis, causing the system to overheat. To prevent a potential overheating problem, you should replace the air filter every 6 months. In certain environments where the air quality is poor, you may have to replace the filter more frequently.

There are two types of air filters used in the Cisco 10008 chassis. Original model chassis use captive screws to hold the filter in a tray, while later model chassis use spring tabs to hold the filter in place without the need for a tray. The following procedures describe how to replace each type of air filter.



**Note**

The following illustrations show the cable management bracket removed for clarity.

### Replacing an Air Filter in a Chassis that Uses a Filter Tray

Use the following procedure to remove and replace an air filter in a chassis that uses a filter tray:

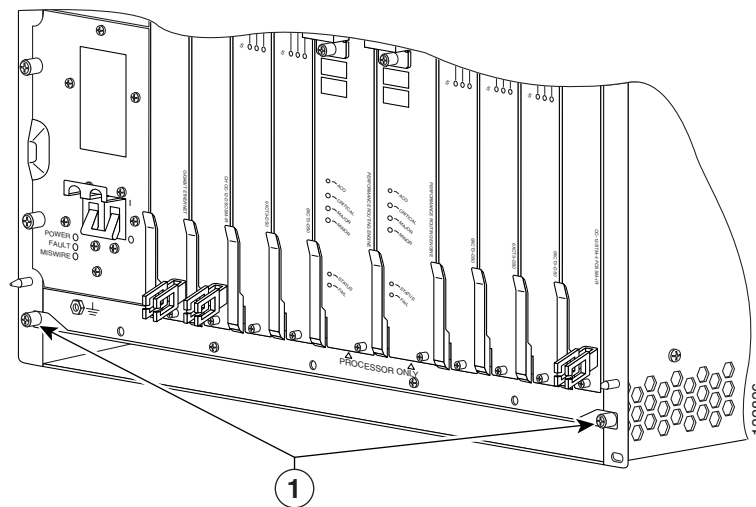
**Figure 5-5** Loosening the Air Filter Tray Captive Screws



<b>1</b>	Filter tray captive screw
----------	---------------------------

- Step 1** Remove the front cover if necessary (see [Front Cover Procedures, page 5-4](#)).
- Step 2** Move any interface cables from the cable brackets on the blower module so they are out of your work area, and then remove the cable brackets from the blower ([Figure 5-10](#)).
- Step 3** Loosen the captive screws on each side of the blower module and disengage the module ([Figure 5-11](#)). Power to the blower will become disconnected.
- Step 4** Loosen the captive screws on the air filter tray ([Figure 5-5](#)).

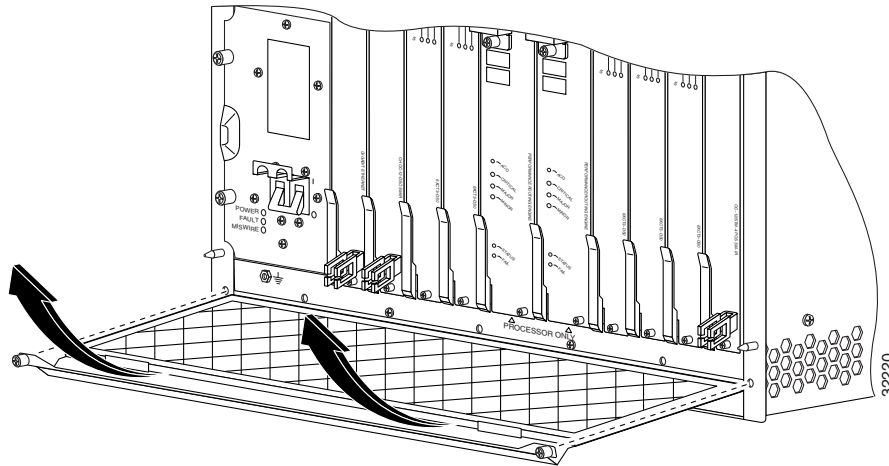
**Figure 5-6** Removing the Air Filter

- Step 5** Pull out the filter tray far enough to remove the air filter (Figure 5-6).

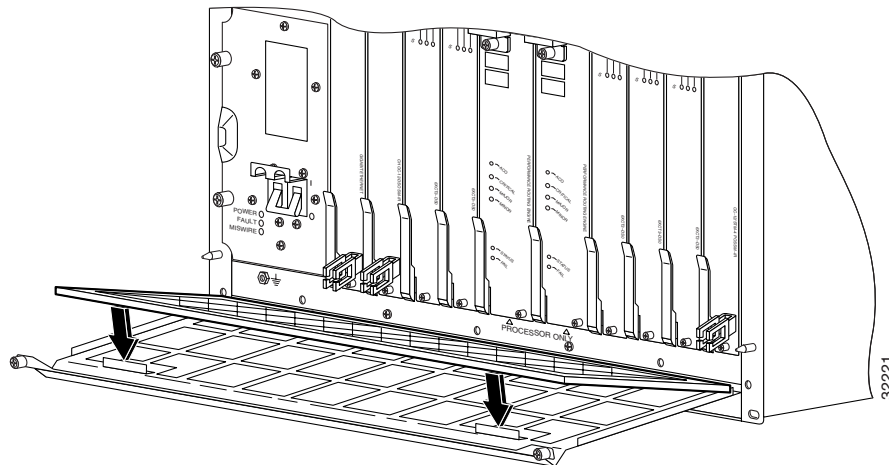
**Figure 5-7** Inserting the New Air Filter

- Step 6** Place the new air filter in the tray so that you can see the directional arrows located on the metal frame (pointing up) and slide the tray into the chassis (Figure 5-7).
- Step 7** Tighten the captive screws to secure the filter to the chassis (Figure 5-7).
- Step 8** Slide the blower module back into the chassis making sure it securely connects to the backplane (Figure 5-12). The FANS OK LED should light (green).
- Step 9** Tighten the captive screws on each side of the blower module (Figure 5-12).
- Step 10** Return all interface cables through the cable management brackets.
- Step 11** Replace the front cover if necessary (see the “Replacing the Front Cover” section on page 5-6).

## Replacing an Air Filter in a Chassis with Release Tabs

Use the following procedure to remove and replace the air filter in a chassis that uses release tabs to hold the filter in place:

**Figure 5-8** Air Filter Release Tabs

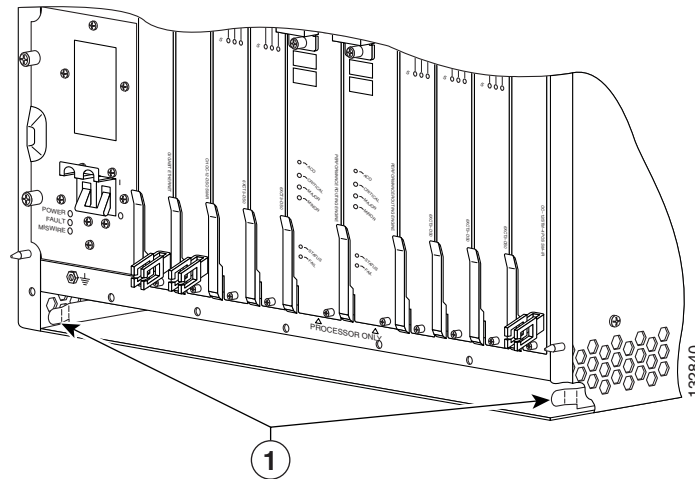

<b>1</b>	Air filter release tabs
----------	-------------------------

**Step 1** Press the release tabs out toward each side of the chassis to release the air filter and slide it out of the chassis ([Figure 5-8](#)).

**Figure 5-9** Inserting the Air Filter

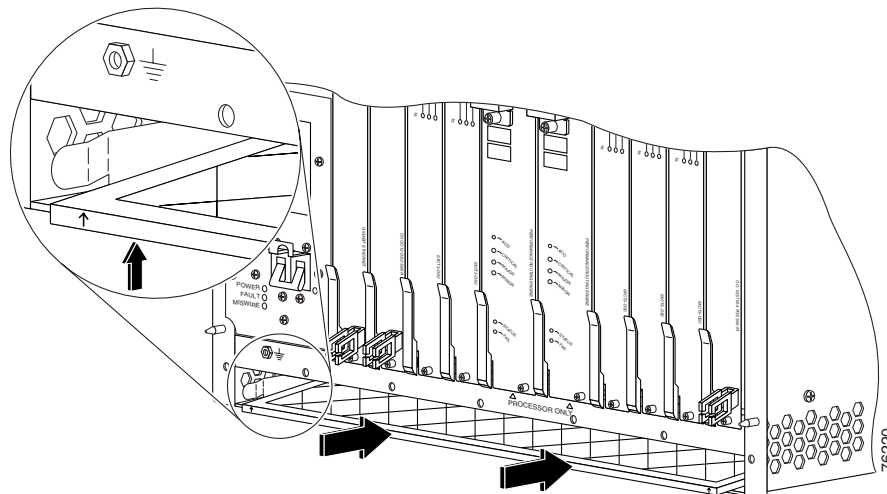

**Step 2** Slide the new filter all of the way into the chassis and lift it up until it snaps into place ([Figure 5-9](#)).

**Note**

The directional arrows located on the metal frame of the filter should point up (see enlargement in [Figure 5-9](#)).

## Replacing the Blower Module

Use the following procedure to replace a blower module. The blower module supports hot-swapping (for up to 2 minutes) and can be replaced without interruption to system operation.

**Caution**

To prevent the possibility of the system overheating, be sure that the replacement blower module is out of its box and packaging, so it is ready to install as soon as the defective module is removed.

**Figure 5-10** Removing the Cable Brackets

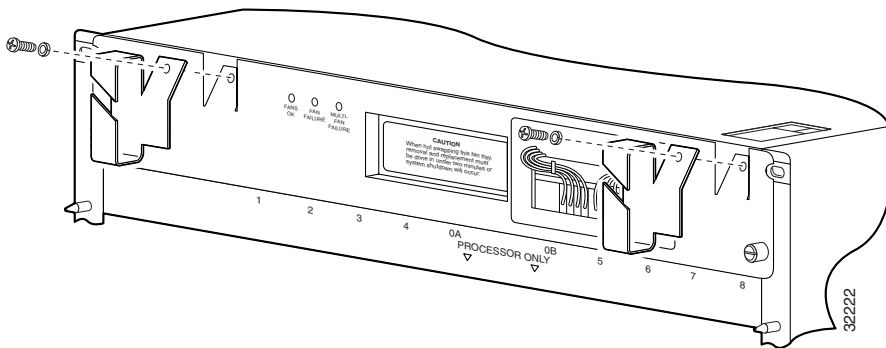

- Step 1** Remove the front cover if necessary (see [Front Cover Procedures, page 5-4](#)).
- Step 2** Move any interface cables from the cable brackets on the blower so they are out of your work area, and then remove the cable brackets from the blower ([Figure 5-10](#)).

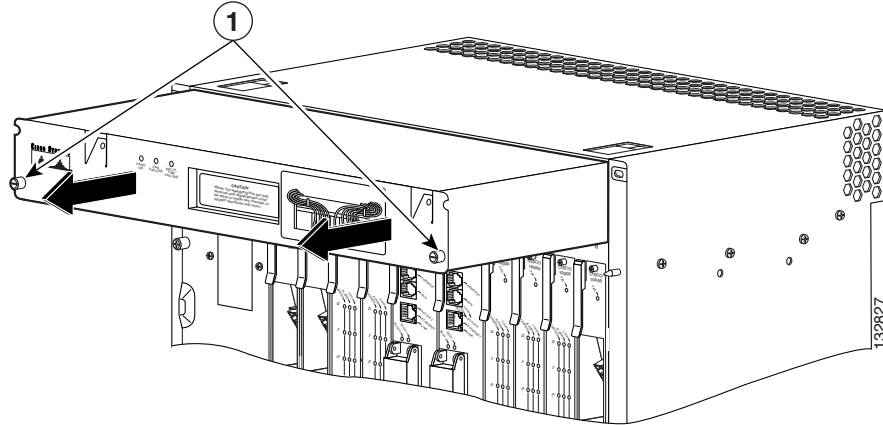
**Figure 5-11** Removing the Blower Module

<b>1</b>	Captive screws		
----------	----------------	--	--

**Step 3** Loosen the captive screws on each side of the blower module and slide the module out of the chassis (Figure 5-11).

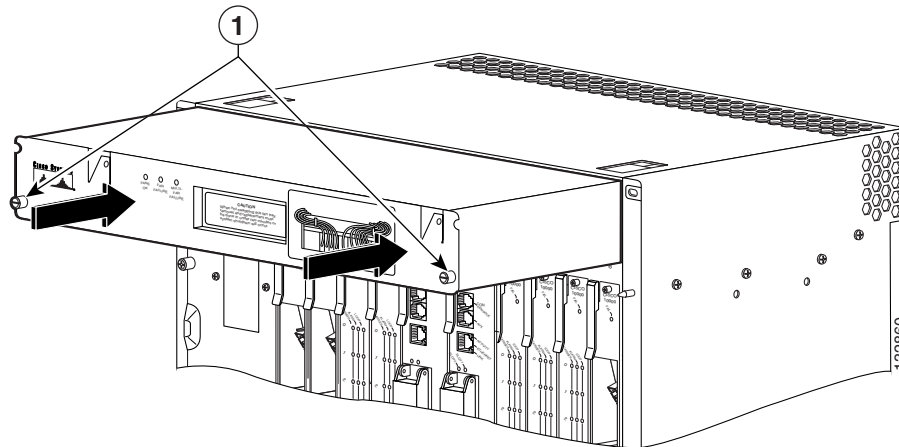
**Figure 5-12** Installing the Blower Module

<b>1</b>	Captive screws		
----------	----------------	--	--

**Step 4** Slide the new blower module into the chassis, being sure it makes a secure connection to the backplane (Figure 5-12).

The FANS OK LED should light (green).

If a FAN FAILURE LED lights (yellow):

- Try reseating the blower module.
- Remove the rear safety cover and make sure the blower module cable is connected securely (Figure 5-13).

Figure 5-13 Blower Module Cable Connector

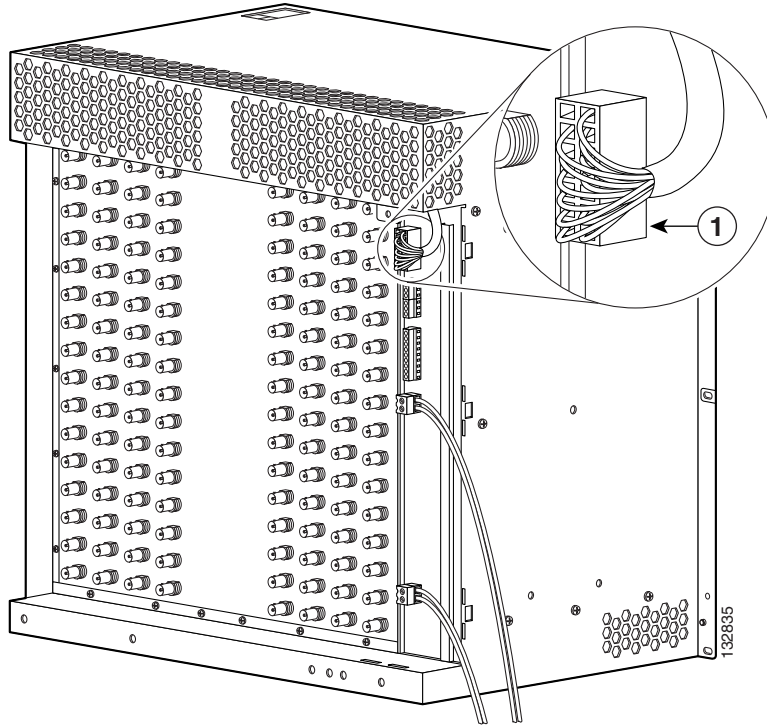

1	Blower module connector		
---	-------------------------	--	--

- Step 5** Tighten the captive screws on each side of the blower module (see [Figure 5-12](#)).
- Step 6** Rerun all interface cables through the cable management brackets.
- Step 7** Replace the front cover if necessary (see the [“Replacing the Front Cover”](#) section on page 5-6).

## Installing Power Entry Modules

This section contains the procedures to install *or* replace AC or DC PEMs.



### Note

If you are adding a second PEM for redundancy, or if you have redundant PEMs, it is not necessary to shut down the system before replacing a PEM.

## Installing a Second DC PEM

Use the following procedure to install a second DC PEM in the bottom power bay for redundancy.



### Caution

Do not power off the primary DC PEM or all data traffic will halt.



Figure 5-14 Removing the Blank Cover

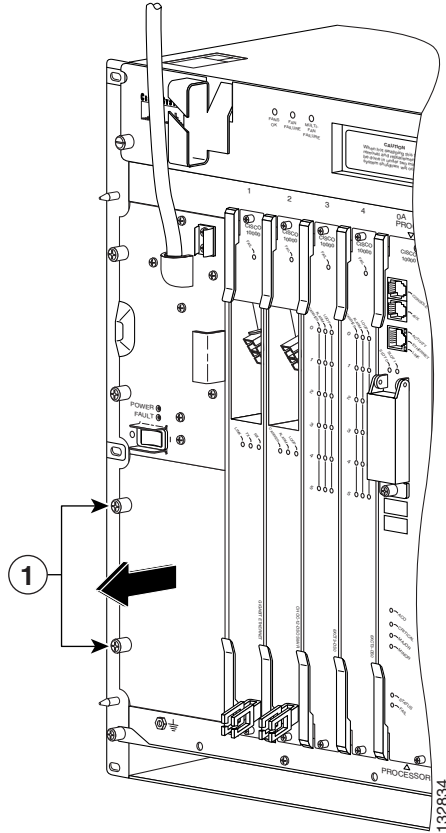

1	Captive screws	
---	----------------	--

**Step 1** Remove the front cover if necessary (see [Front Cover Procedures](#), page 5-4).

**Step 2** Loosen the captive screws to remove the blank cover from the bottom power bay ([Figure 5-14](#)).

Figure 5-15 Installing a DC PEM

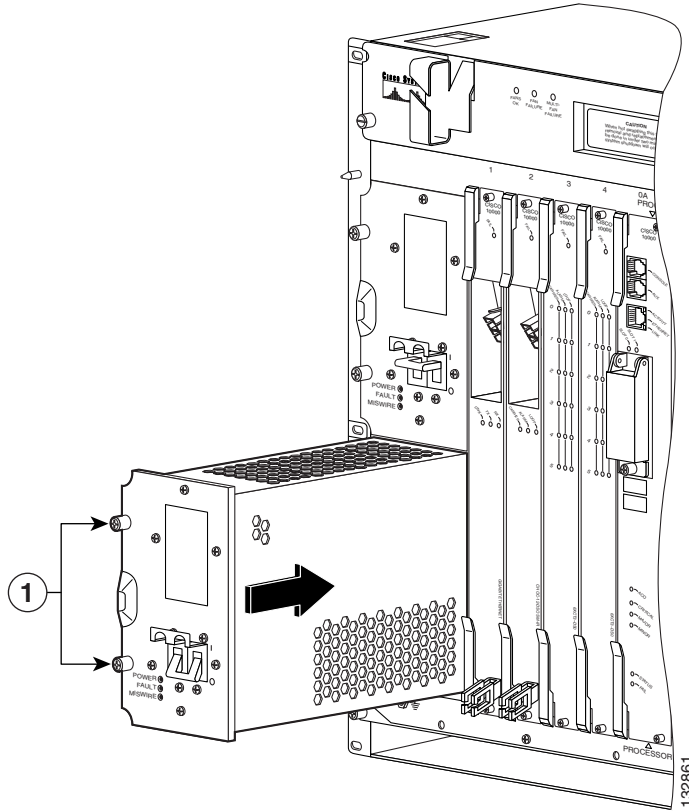

1	Captive screws		
---	----------------	--	--

**Step 3** Install the new DC PEM all the way into the power bay to ensure a secure connection to the backplane, and tighten the captive screws (Figure 5-15).

**Figure 5-16** Loosening the Captive Screw

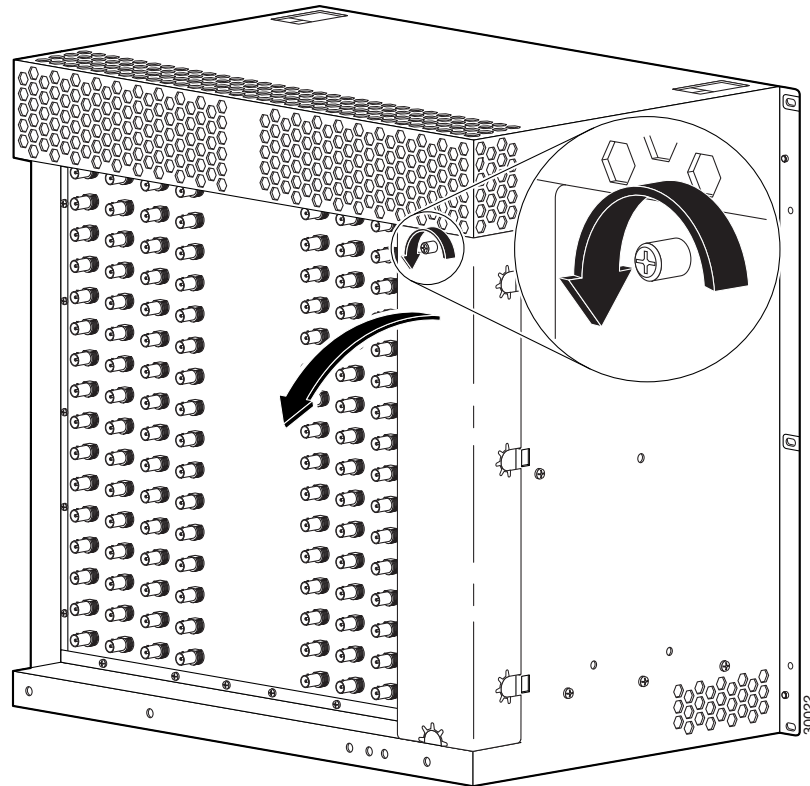

**Step 4** Loosen the captive screw on the rear safety cover and tilt back the cover (Figure 5-16).

**Figure 5-17** Removing the Safety Cover

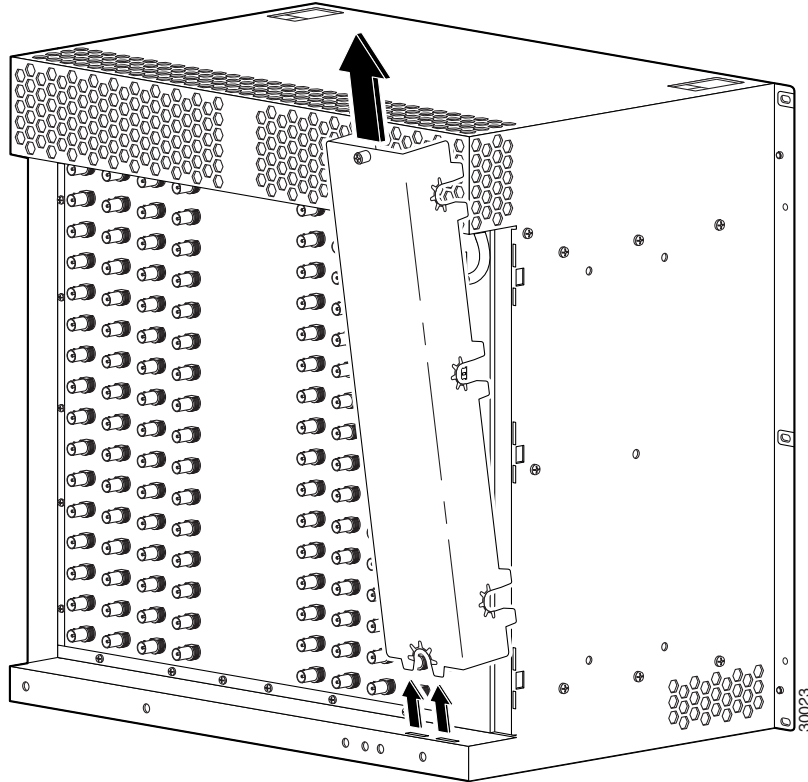

**Step 5** Remove the safety cover by lifting it up and out from the chassis (Figure 5-17).

Figure 5-18 DC Power Connection

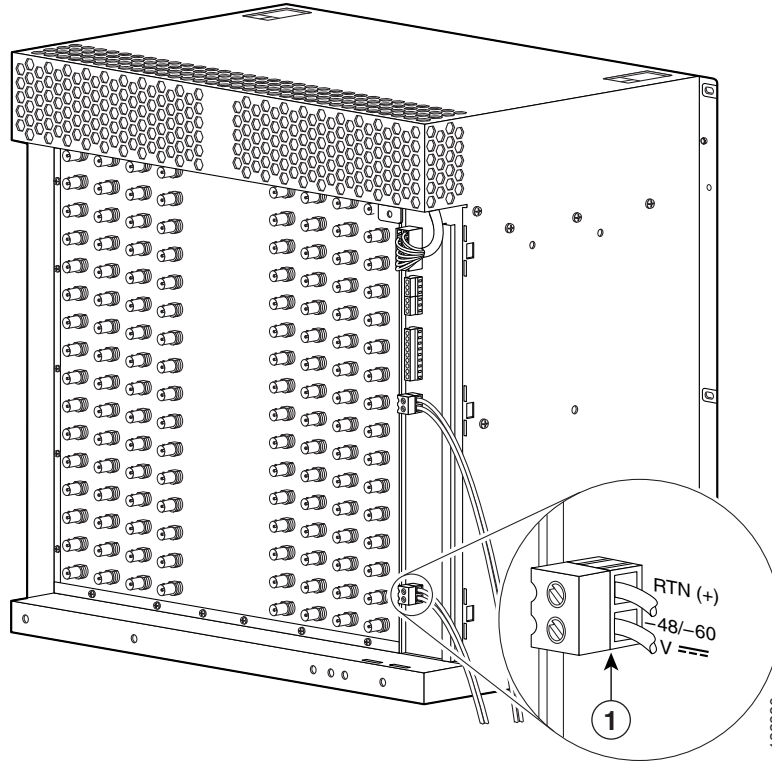

1	DC terminal block B
---	---------------------

**Step 6** Connect the DC PEM power leads:

- Connect the DC power lead from the external power source to the DC terminal block B labeled –48V (Figure 5-18).
- Connect the return wire (RTN) to terminal block B labeled RTN (+) (Figure 5-18).

**Figure 5-19** Securing DC Power Cables to the Chassis

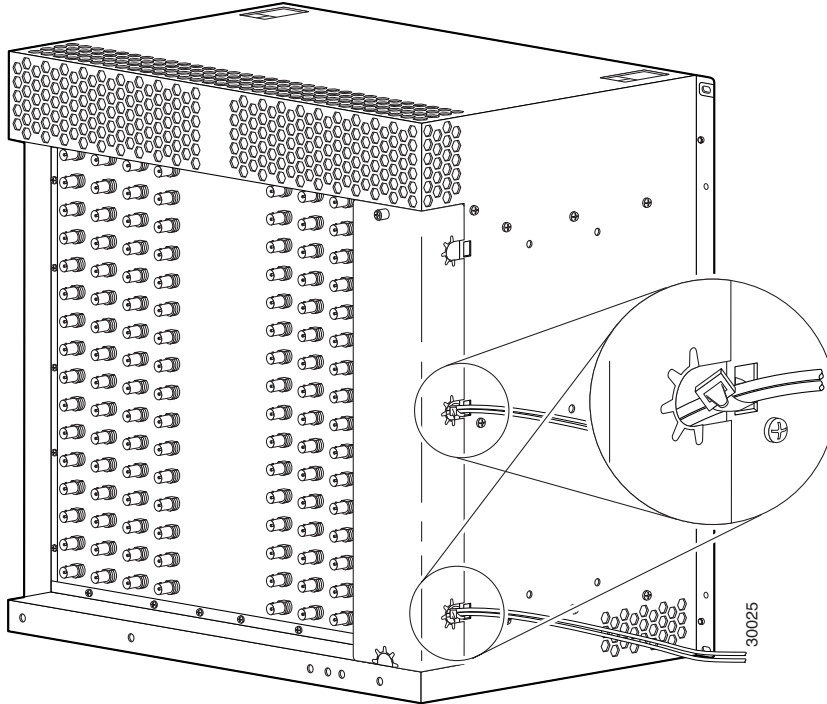

- Step 7** Secure the power cabling to the chassis by feeding a tie wrap through the slot on the side of the chassis and binding the cables (Figure 5-19).
- Step 8** Replace the rear safety cover, making sure that the power cables exit through the holes on the side of the cover (Figure 5-19).

**Figure 5-20** Setting DC Power Switch to the On Position

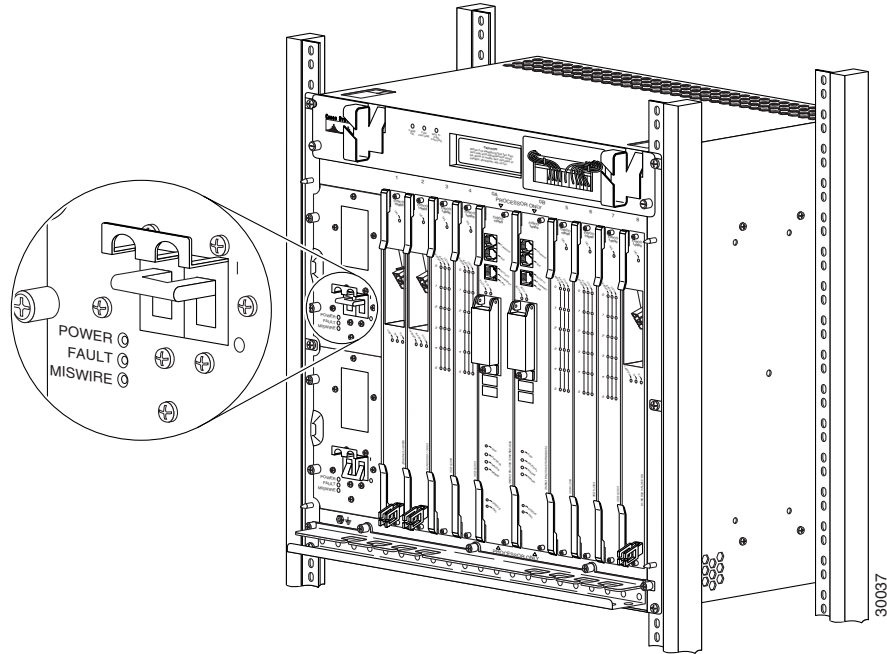

- Step 9** Set the power switch to the on (I) position ([Figure 5-20](#)).
- Step 10** Replace the front cover if necessary (see the [“Replacing the Front Cover”](#) section on page 5-6).

## Replacing a DC PEM

Use the following procedure to replace a DC PEM:

**Figure 5-21** Setting DC Power Switch to the Off Position

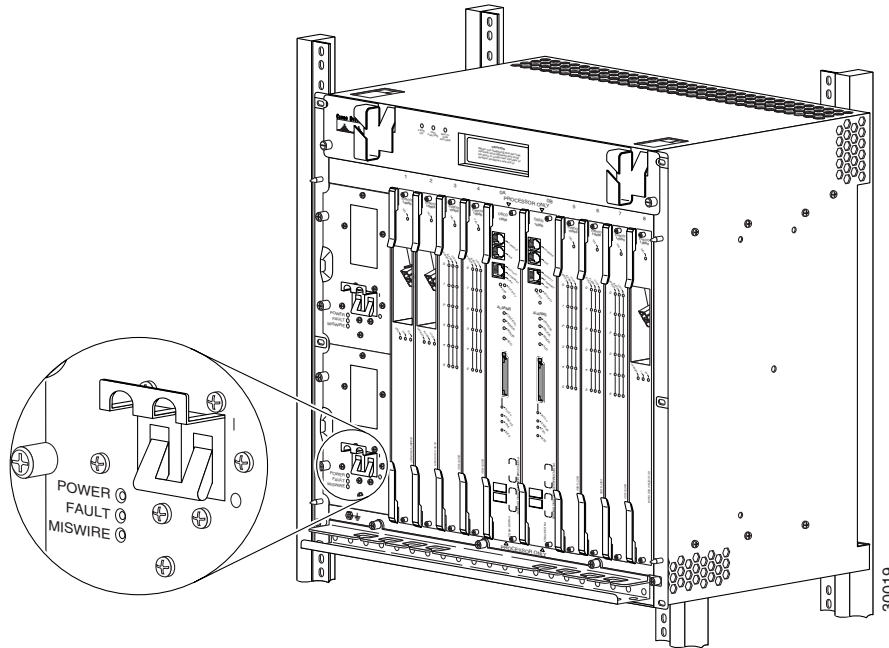

- 
- Step 1** Remove the front cover if necessary (see [Front Cover Procedures, page 5-4](#)).
- Step 2** Set the power switch to the off (0) position. If you have redundant PEMs, set only the power switch of the PEM you are replacing to the off (0) position (the example in [Figure 5-21](#) shows the top PEM in the off position).



**Caution**

Do not power off both of the DC PEMs in a redundant system, or the system shuts and down all data traffic stops. Only power off the DC PEM you are replacing.

---



Figure 5-22 Removing a DC PEM

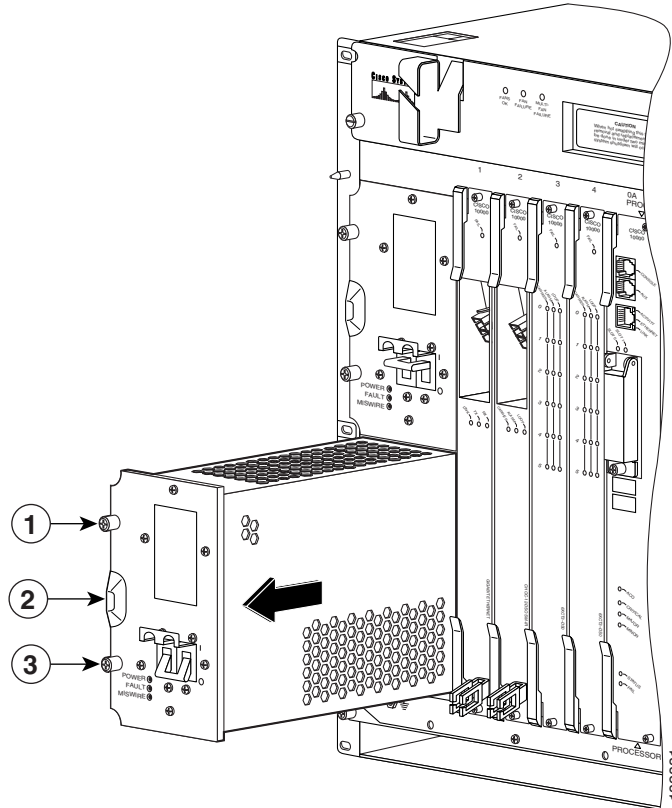

1	Captive screw	2	Handle
---	---------------	---	--------

**Step 3** Loosen the captive screws on the DC PEM you are removing and pull the PEM from the chassis using the handle on the faceplate (Figure 5-22).

Figure 5-23 Installing a DC PEM

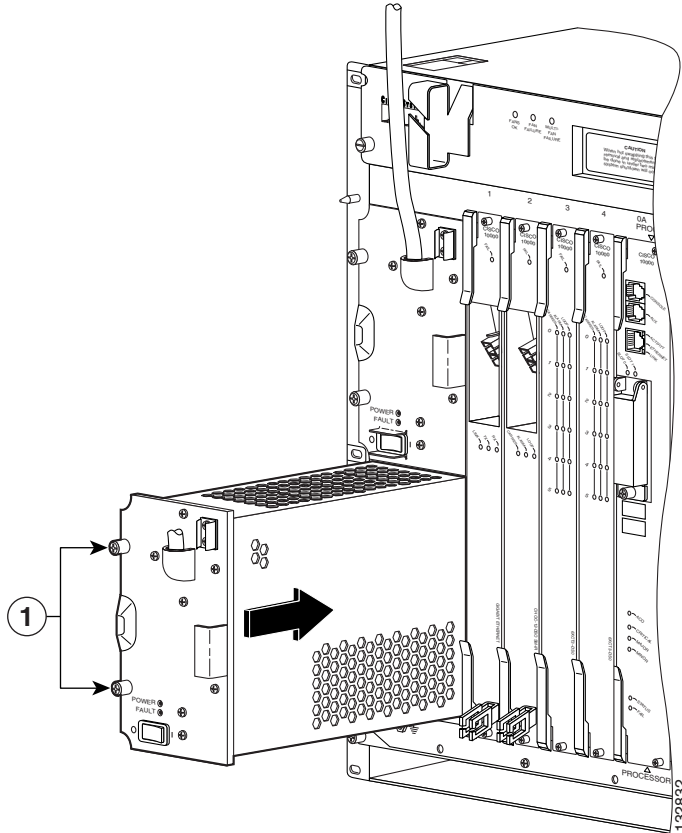

1	Captive screws
---	----------------

**Step 4** Install the new DC PEM all the way into the power bay to ensure a secure connection to the backplane, and tighten the captive screws (Figure 5-23).

**Figure 5-24** Setting DC Power Switch to the On Position

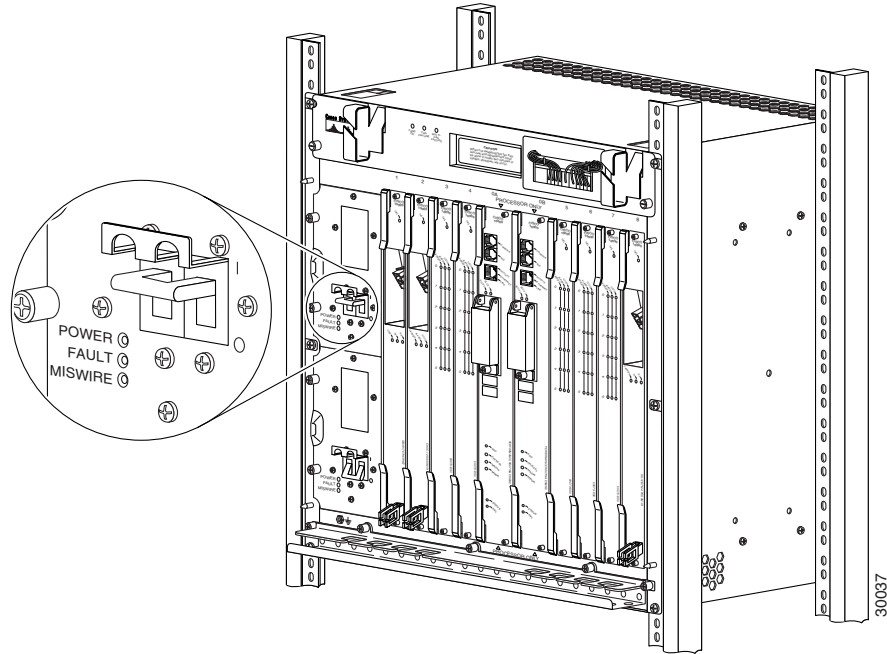

- Step 5** Set the power switch to the on (I) position ([Figure 5-24](#)).
- Step 6** Replace the front cover if necessary (see the [“Replacing the Front Cover”](#) section on page 5-6).
-

## Installing a Second AC PEM

Use the following procedure to install a second AC PEM in the bottom power bay for redundancy:

**Figure 5-25** Removing the Blank Cover

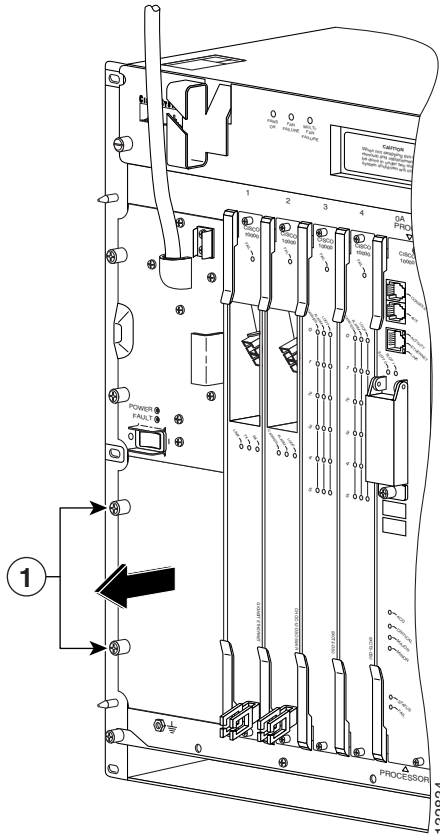

1	Captive screws		
---	----------------	--	--

- Step 1** Remove the front cover if necessary (see [Front Cover Procedures, page 5-4](#)).
- Step 2** Loosen the captive screws to remove the blank cover from the bottom power bay ([Figure 5-25](#)).

Figure 5-26 Installing an AC PEM

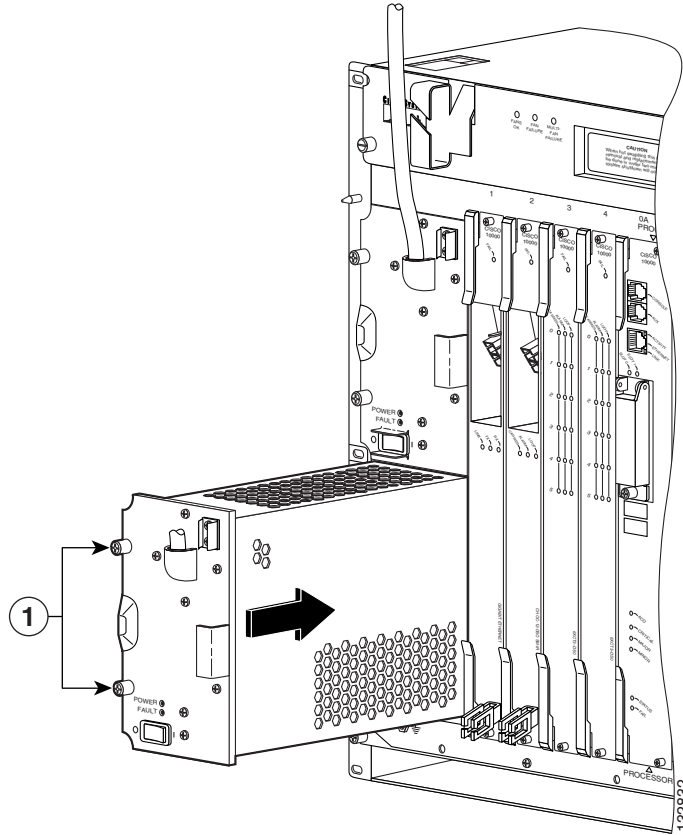

1	Captive screws
---	----------------

- Step 3** Install the new AC PEM all the way into the power bay to ensure a secure connection to the backplane and tighten the captive screws (Figure 5-26).
- Step 4** Connect the power cord from the PEM to your power cord that connects to the facility VAC input.

**Figure 5-27** AC Power Cord Connectors in Strain Relief Devices

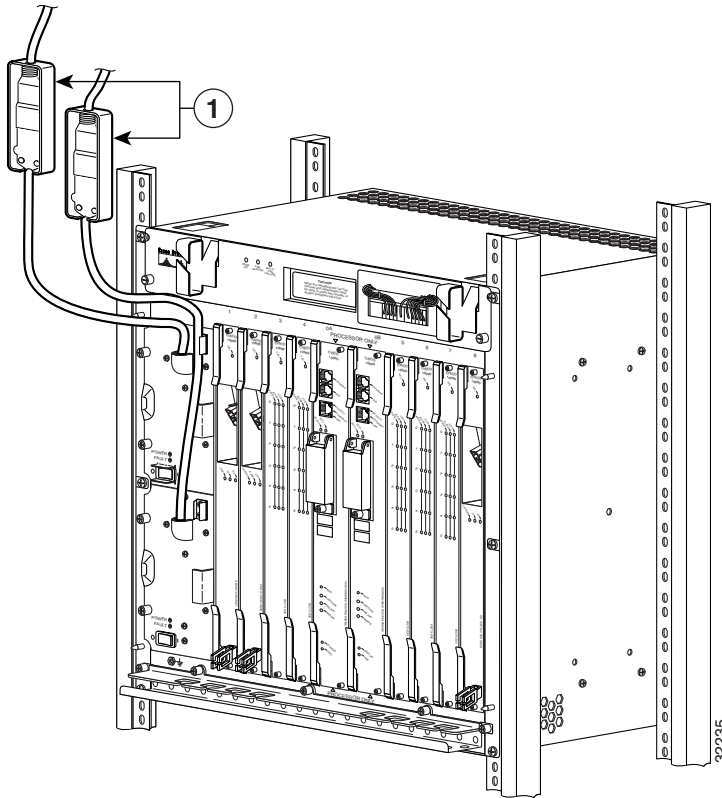

<b>1</b>	Strain relief devices
----------	-----------------------

- Step 5** Set the AC power cord connectors in strain relief devices to prevent them from accidentally disconnecting (Figure 5-27).
- Step 6** Plug the facility AC input power cord into a power receptacle.

**Figure 5-28** Setting the AC Power Switch to the On Position

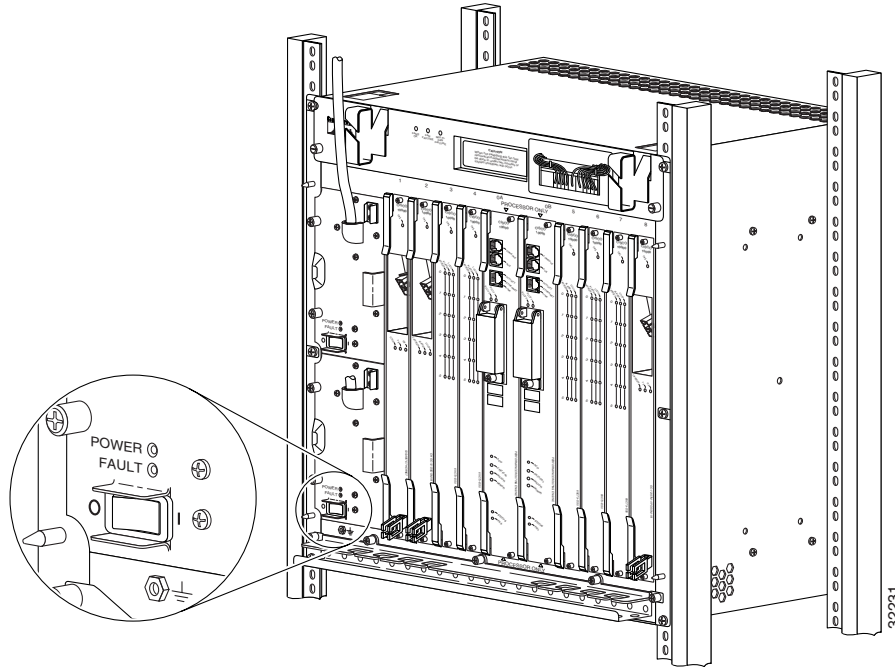

- Step 7** Set the power switch to the on (I) position ([Figure 5-28](#)).  
The green LED on the PEM lights indicating that the PEM is on.
- Step 8** Replace the front cover if necessary (see the [“Replacing the Front Cover”](#) section on page 5-6).
-

## Replacing an AC PEM

Use the following procedure to replace an AC PEM:

**Figure 5-29** Setting AC Power Switch to the Off Position

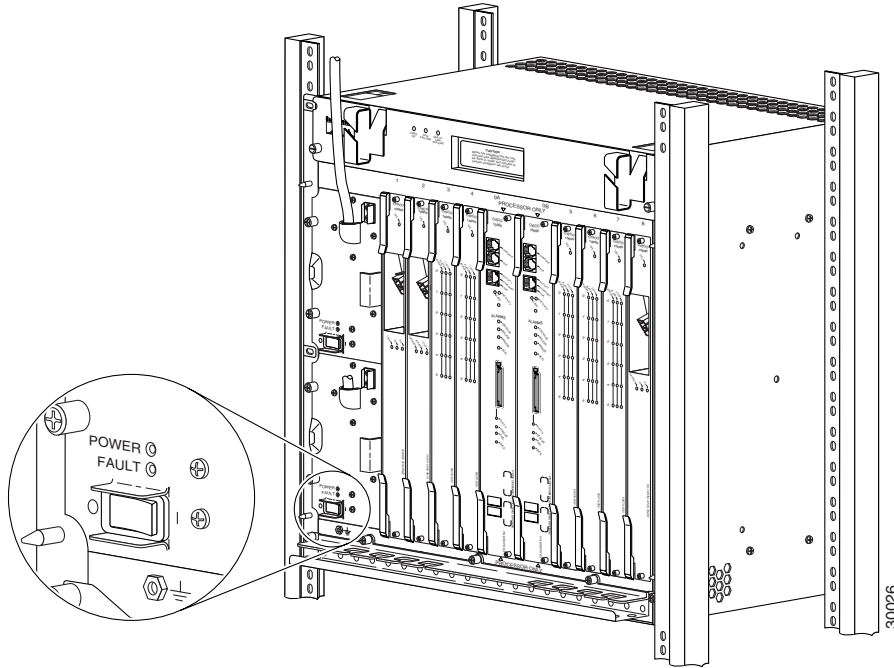

- 
- Step 1** Remove the front cover if necessary (see [Front Cover Procedures, page 5-4](#)).
- Step 2** If your system is configured with redundant PEMs, set only the power switch of the PEM you are replacing to the off (0) position (the example in [Figure 5-29](#) shows the top PEM in the off position).



**Caution** Do not power off both AC PEMs in a redundant system, or the system shuts down and all data traffic stops. Only power off the AC PEM you are replacing.

---

- Step 3** Remove the PEM power cable from its canoe and disconnect it from the AC input power cable.



Figure 5-30 Removing an AC PEM

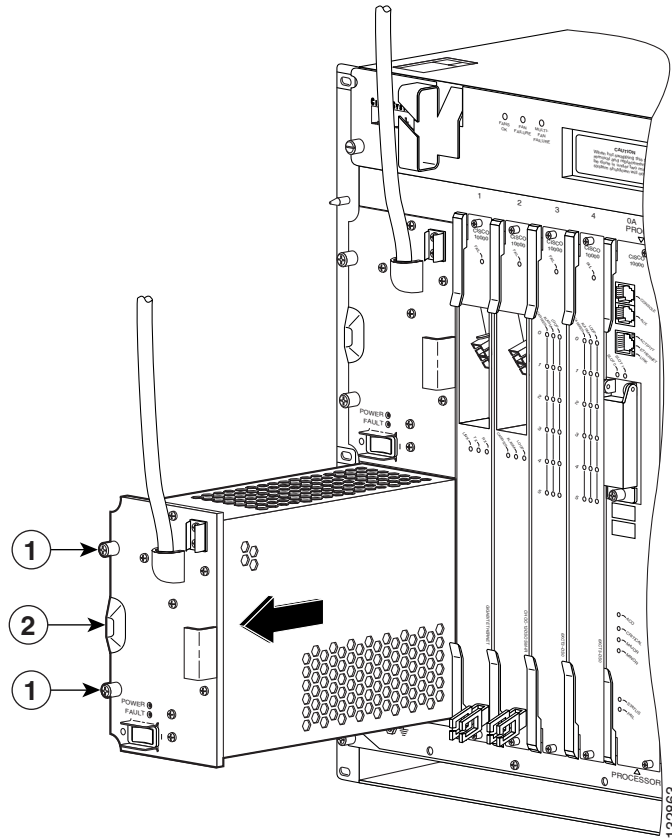

1	Captive screw	2	Handle
---	---------------	---	--------

**Step 4** Loosen the captive screws on the PEM you are removing and pull the PEM from the chassis using the handle on the faceplate (Figure 5-30).

Figure 5-31 Installing an AC PEM

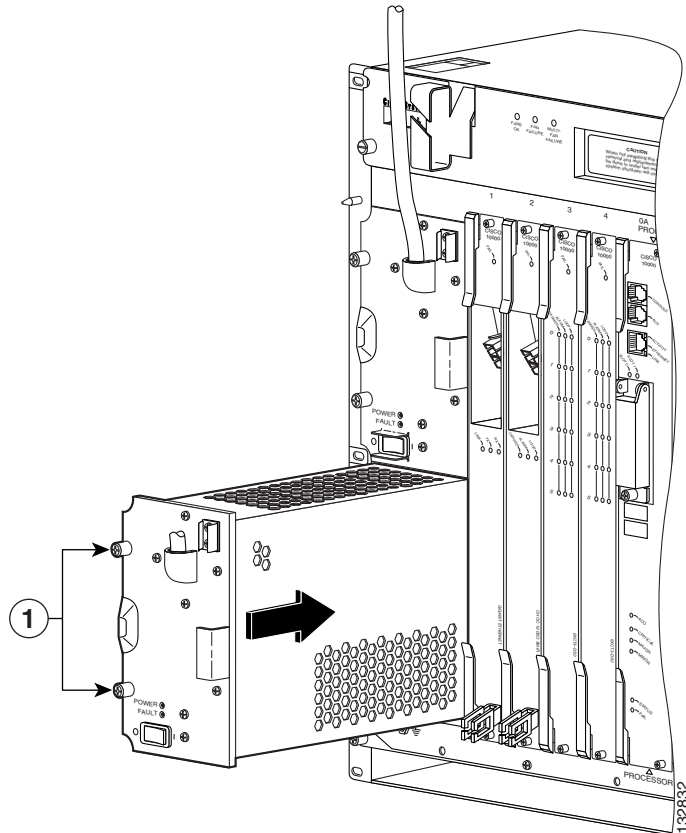

1	Captive screws
---	----------------

- Step 5** Install the new AC PEM all the way into the power bay to ensure a secure connection to the backplane and tighten the captive screws on the PEM (Figure 5-31).
- Step 6** Connect the power cord from the PEM to the power cord that connects to the facility VAC input.

**Figure 5-32 AC Power Cord Connectors in Canoes**

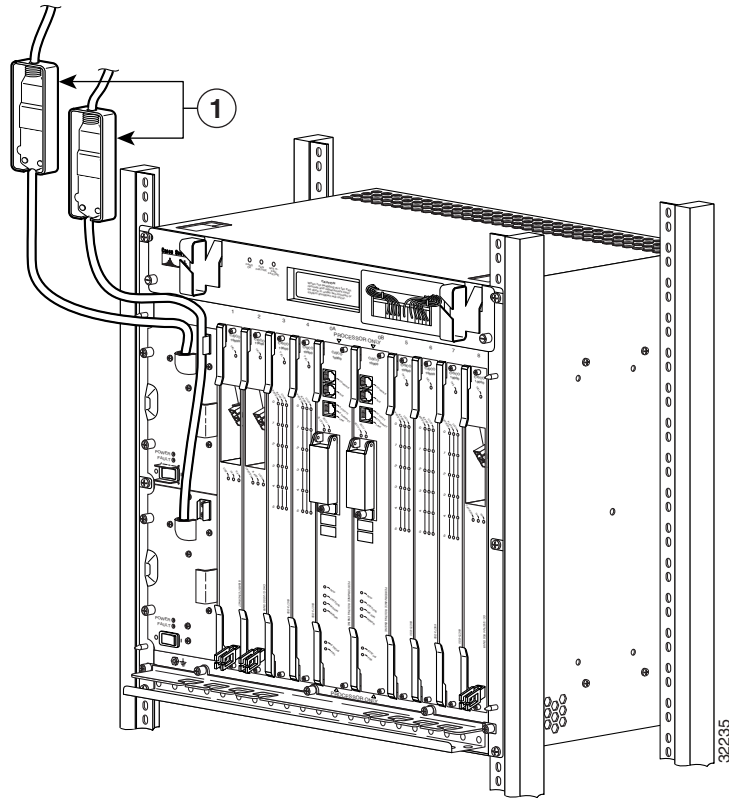

<b>1</b>	Strain relief devices	
----------	-----------------------	--

- Step 7** Set the AC power cord connectors in a cord strain relief device to prevent them from accidentally disconnecting (Figure 5-32).
- Step 8** Plug the facility AC input power cord into a power receptacle.

**Figure 5-33** Setting AC Power Switch to the On Position

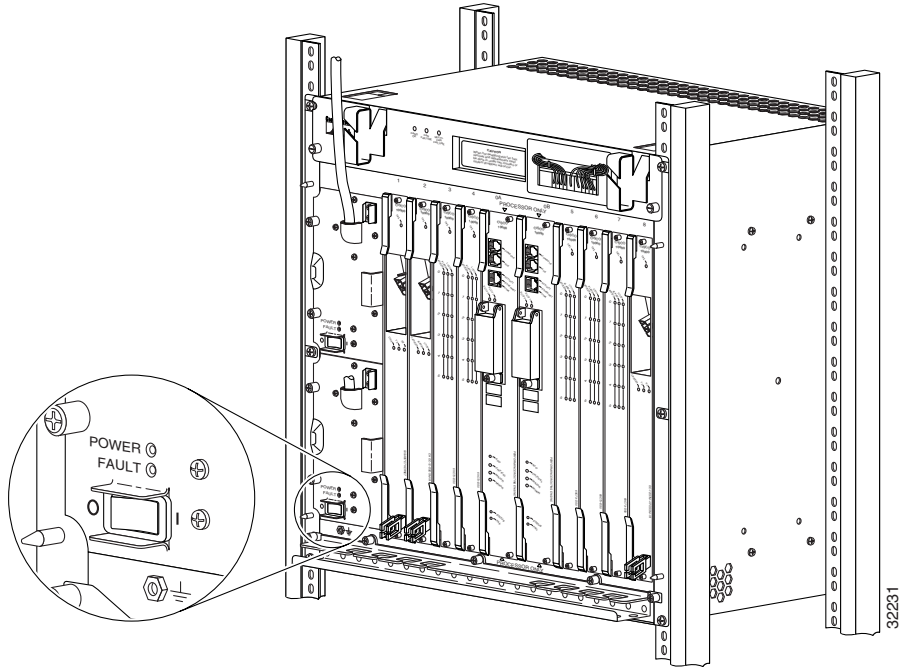

**Step 9** Set the power switch to the on (I) position ([Figure 5-33](#)).

The green LED on the PEM lights indicating that the PEM is on.

**Step 10** Replace the front cover if necessary (see the [“Replacing the Front Cover”](#) section on page 5-6).

## Connecting Alarm Indicators

The Cisco 10008 router provides relay contacts for optional (customer-supplied) audible or visual alarm indicators. Relay contacts are provided for three levels of severity:

- Minor—This is an informational alarm and does not affect the system operation.
- Major—A condition that affects system operation and should be investigated as soon as possible.
- Critical—A condition that affects system operation and requires immediate attention.

Use the following procedure to connect an alarm indicator to the system:

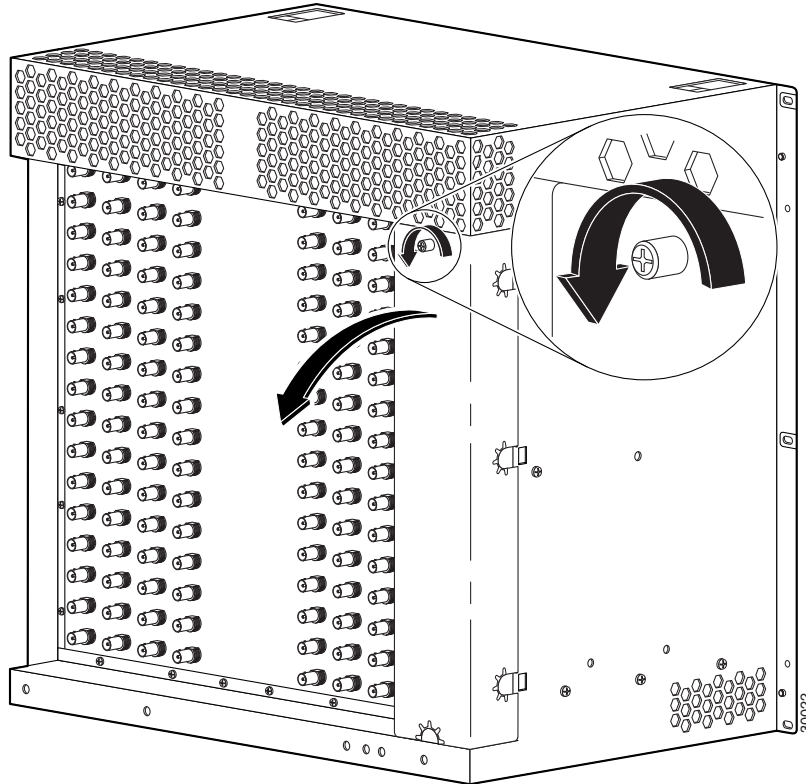
**Figure 5-34** Removing the Safety Cover

- 
- Step 1** Set the AC or DC PEM power switches to the off (0) position.
- Step 2** Loosen the captive screw on the rear safety cover and tilt the cover back (Figure 5-34).

**Figure 5-35** Removing the Rear Cover

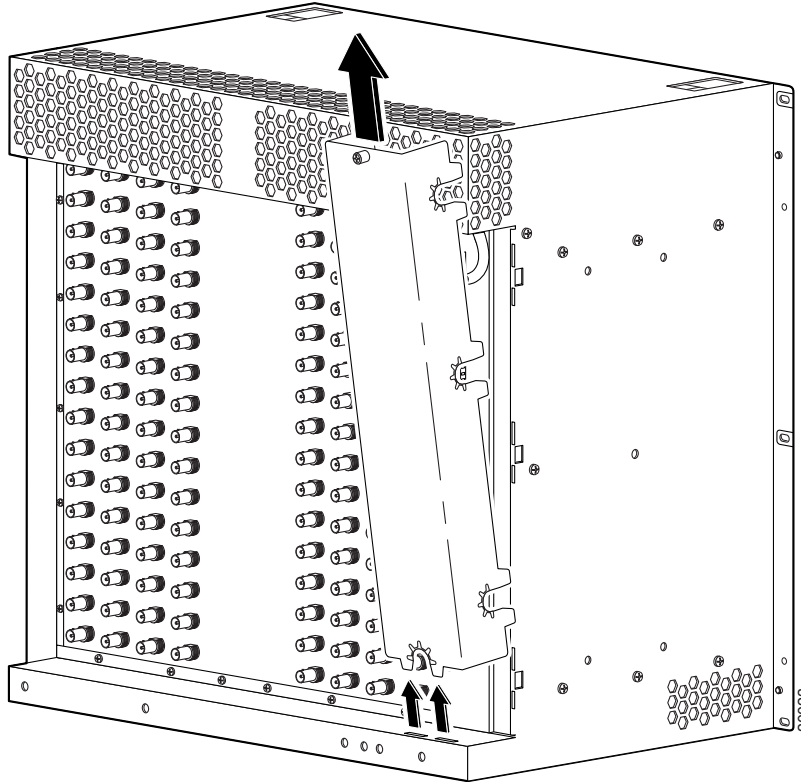

**Step 3** Remove the safety cover by lifting it up and out from the chassis (Figure 5-35).

**Figure 5-36** Stripping Insulation

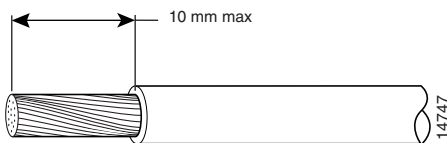

**Step 4** Strip not more than 0.4 inches (10 mm) of insulation off of the ends of the alarm indicator wire (Figure 5-36).

Figure 5-37 Alarm Terminal Block Connections

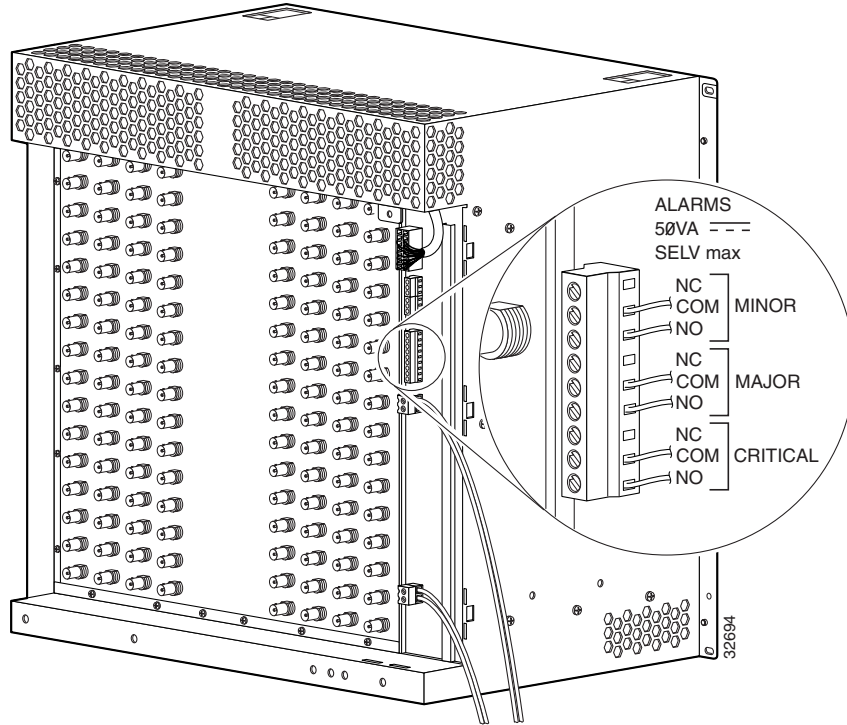

- Step 5** Connect one set of alarm indicator wires to the alarm terminal block as follows:
- Connect one lead to the common (COM) terminal (Figure 5-37).
  - Connect the other lead to the normally closed (NC) or normally open (NO) terminal.

**Caution**

Figure 5-37 shows the wiring configuration for normally open (NO) alarm relays. If you are wiring the router in *series* with other equipment for the alarm indicators, use the normally closed (NC) terminals. If you are wiring the router in *parallel* with other equipment for the alarm indicators, use the NO terminals.

- Step 6** Repeat steps 1 and 2 for any remaining alarm indicators.

**Figure 5-38 Alarm Indicator Wires Exiting Safety Cover**

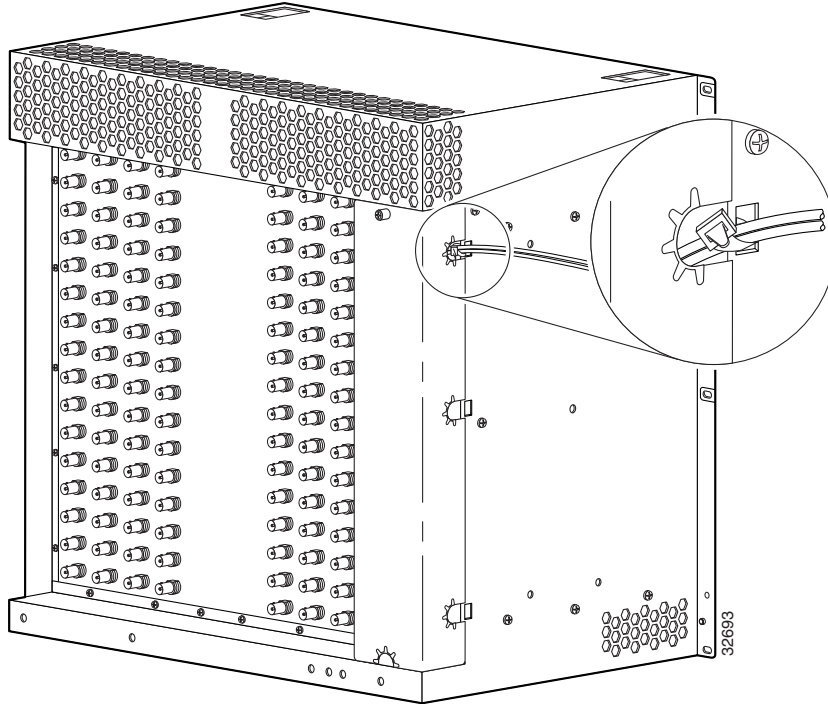

- Step 7** Secure the power cabling to the chassis by feeding a tie wrap through the slot on the side of the chassis and binding the cables (see blowout in [Figure 5-38](#)).
- Step 8** Replace the rear safety cover, making sure that the alarm indicator wires exit through the holes on the side of the cover ([Figure 5-38](#)).

## Removing and Replacing the PRE

Use the following procedure to install or to remove and replace a PRE module.



### Caution

Do not operate the system unless all slots contain a line card or a blank faceplate. Blank faceplates are necessary in empty slots to prevent exposure to hazardous voltages, to reduce electromagnetic interference (EMI) that may disrupt other equipment, and to direct the flow of cooling air through the chassis.



Figure 5-39 ESD Chassis Connection

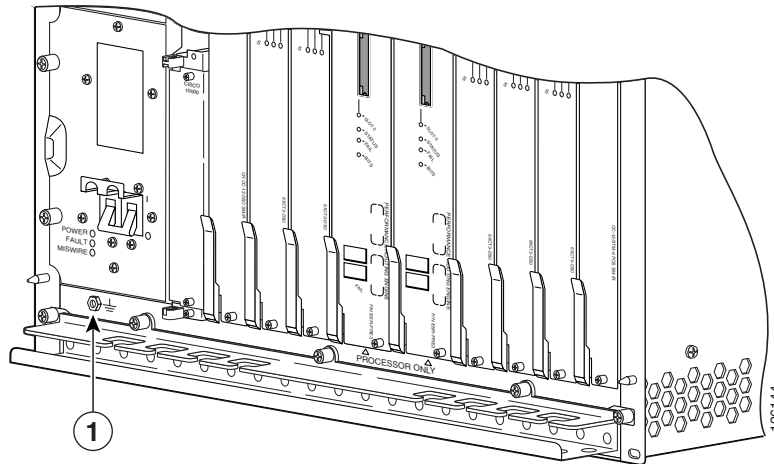

<b>1</b>	ESD socket
----------	------------

- Step 1** Remove the front cover if necessary (see [Front Cover Procedures, page 5-4](#)).
- Step 2** Attach an antistatic wrist strap to your wrist and to the ESD socket on the chassis, or to a bare metal surface on the chassis or frame ([Figure 5-39](#)).
- If you are removing and replacing a PRE, continue with the next step.
  - If you are installing a redundant PRE, go to Step 8.
- Step 3** Disconnect any interface cables from the PRE if necessary.
- Step 4** Remove the PCMCIA card from the PRE (see the [“Removing and Installing a PCMCIA Flash Memory Card” section on page 5-44](#)).

Figure 5-40 Loosening the Captive Screws

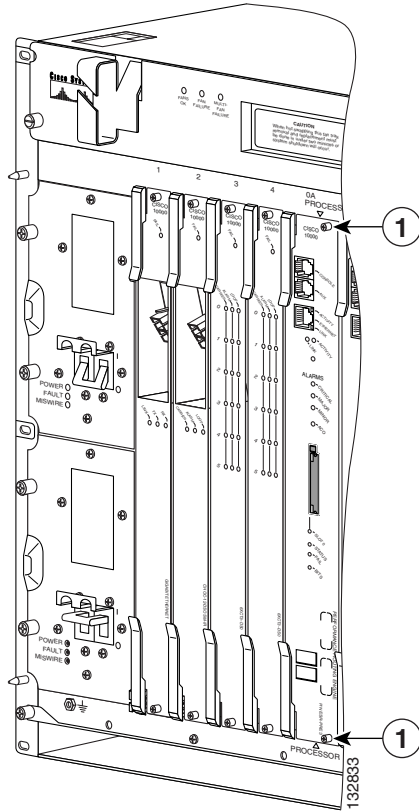

<b>1</b>	Captive screw	
----------	---------------	--

**Step 5** Unscrew the top and bottom captive screws on the PRE (Figure 5-40).

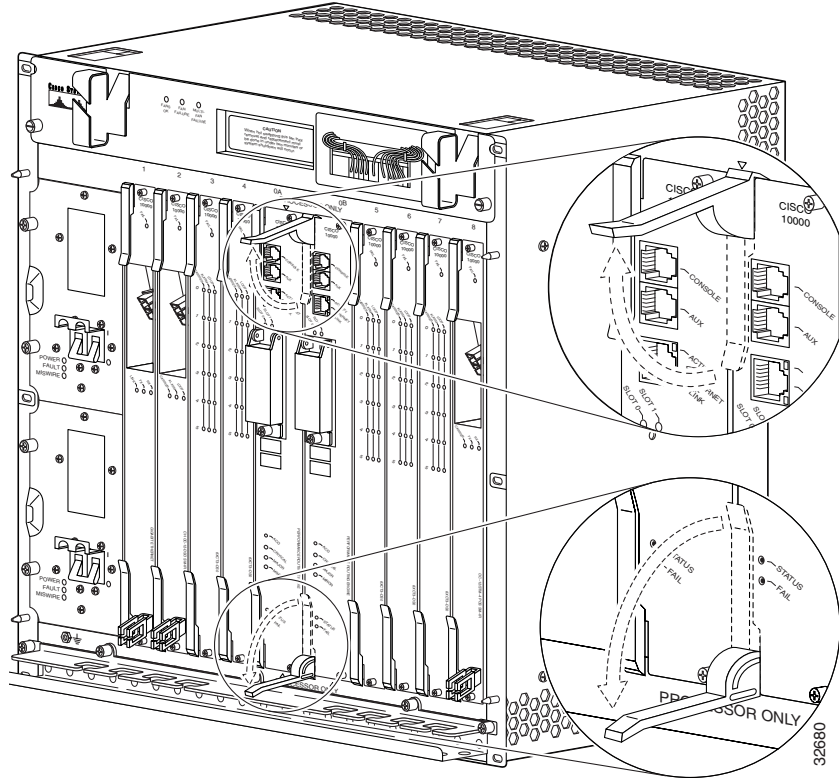
**Figure 5-41** Opening the Ejector Levers

- Step 6** Simultaneously pivot both ejector levers away from each other to disengage the PRE from the backplane (Figure 5-41).

Figure 5-42 Removing the PRE

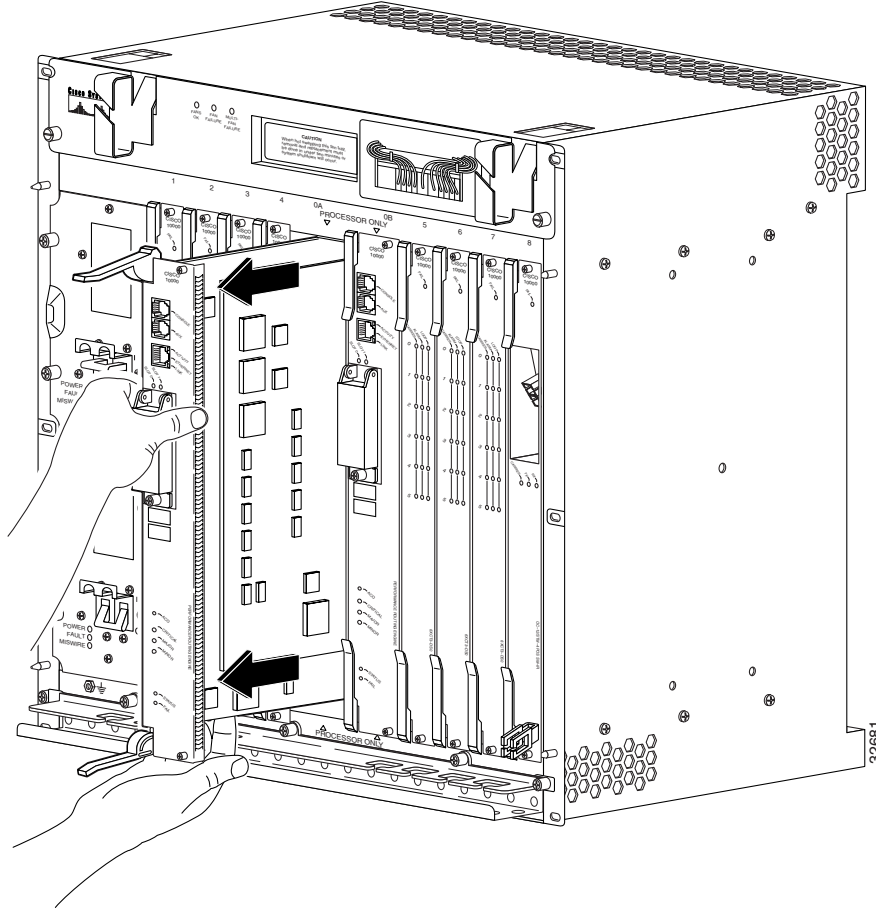

- Step 7** Slide the PRE out of the slot and place it on an antistatic surface, or in an antistatic bag (Figure 5-42).
- Step 8** Grasp the faceplate of the new PRE with one hand and place your other hand under the card carrier (to support the weight of the module) and position the card in front of the card cage slot.

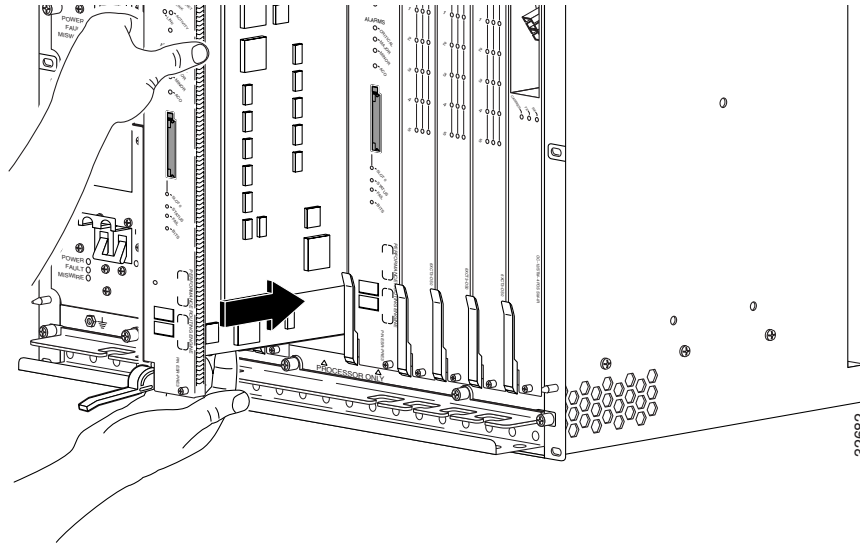
**Figure 5-43** Inserting the PRE

- Step 9** Carefully align the upper and lower edges of the PRE with the upper and lower guides in the chassis, and slide the module into the slot until you can feel it begin to seat in the backplane connectors (Figure 5-43).

**Figure 5-44** Closing the Ejector Levers

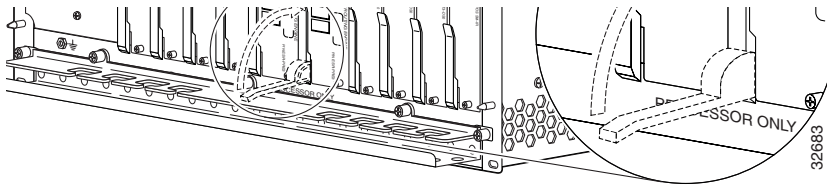

- Step 10** Simultaneously pivot both ejector levers toward each other (until they are parallel to the faceplate) to firmly seat the PRE in the backplane ([Figure 5-44](#)).
- The PRE cycles through its power-on self-test. The Fail LED stays on briefly (about 5 to 6 seconds) and then shuts off. If the Fail LED remains on or is flashing, go to the [“Troubleshooting Installation Problems”](#) section on page 4-12.

Figure 5-45 Tightening Captive Screws

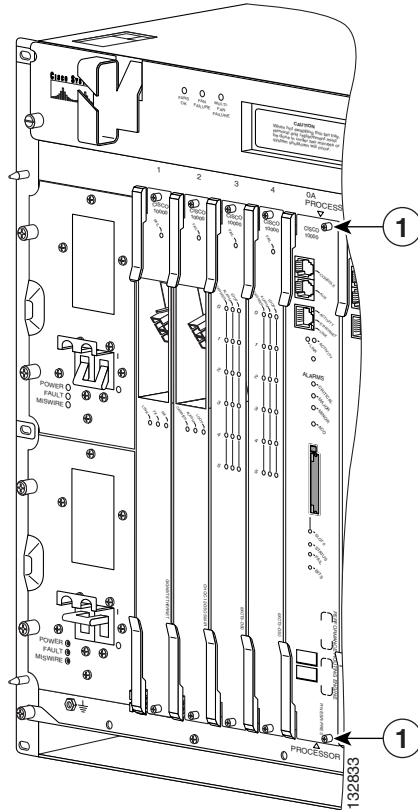

1	Captive screw
---	---------------

**Step 11** Secure the PRE in the chassis by tightening the top and bottom captive screws (Figure 5-45).

**Caution**

Always tighten the captive screws on each newly installed PRE. These screws prevent accidental removal and provide proper grounding for electromagnetic interference (EMI) shielding.

**Step 12** Reconnect any interface cables to the PRE if necessary.

**Step 13** Install the PCMCIA card in the PRE if necessary (see the “Removing and Installing a PCMCIA Flash Memory Card” section on page 5-44).

**Step 14** See the *Cisco 10000 Series Router Performance Routing Engine Installation* for information about configuring the PRE if necessary.

**Note**

It is not necessary to configure the PRE if this is a second PRE installation for redundancy. The system automatically downloads the necessary configuration information from the primary PRE.

**Step 15** Replace the front cover if necessary (see the “Replacing the Front Cover” section on page 5-6).

## Removing and Installing a PCMCIA Flash Memory Card

Use the following procedure to remove and install a PCMCIA flash memory card:



### Note

For information about formatting Flash memory cards and disks, see the “[Formatting Flash Memory Cards and Disks](#)” section on page 4-6.

- Step 1** Remove the front cover if necessary (see [Front Cover Procedures](#), page 5-4).
- Step 2** Loosen the captive screw on the PCMCIA flash card cover on the PRE (Figure 5-46).

**Figure 5-46** PCMCIA Flash Card Cover Captive Screws

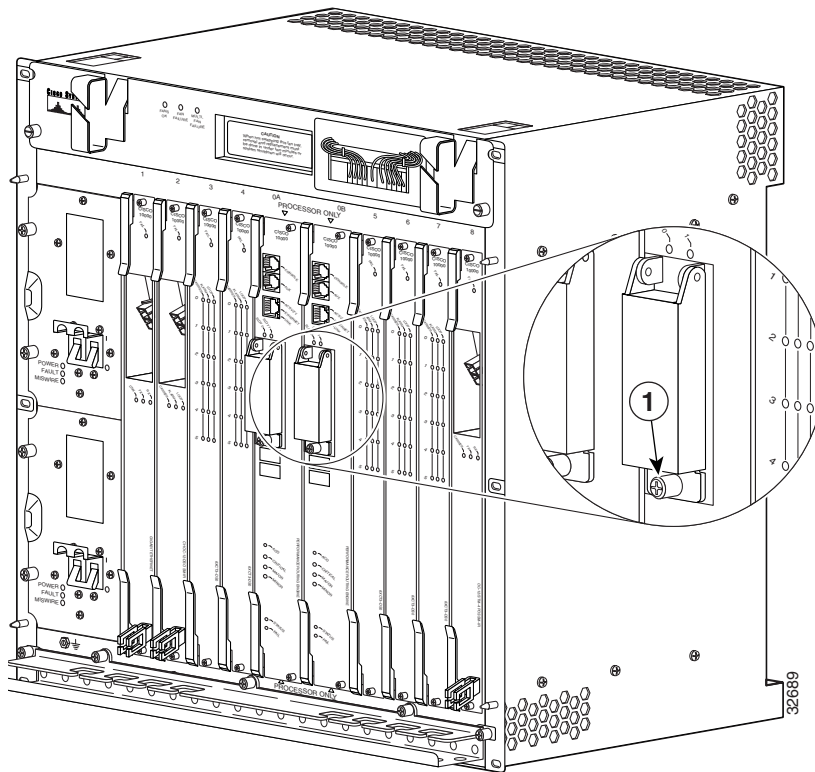

<b>1</b>	Captive screw
----------	---------------

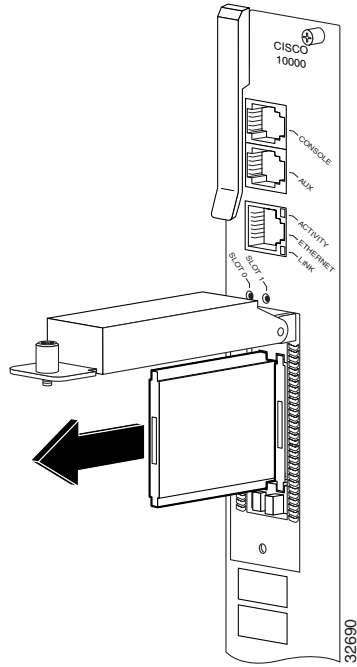

**Figure 5-47** Removing the PCMCIA Flash Card

**Step 3** Lift the cover and pull the flash card up and out of its slot (Figure 5-47).

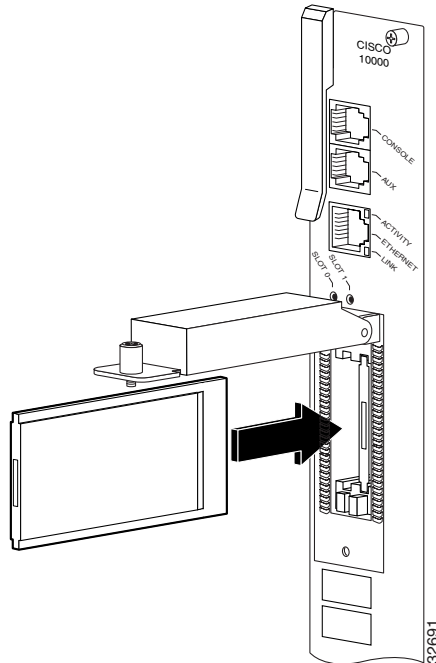
**Figure 5-48** Inserting the PCMCIA Flash Card

**Step 4** Insert the new PCMCIA flash card into one of the card slots on the PRE (Figure 5-48).

**Caution**

Always tighten the captive screw on the PCMCIA flash card cover to prevent the risk of a harmful ESD event and to ensure electromagnetic interference (EMI) shielding.

**Figure 5-49** Tightening the Captive Screw

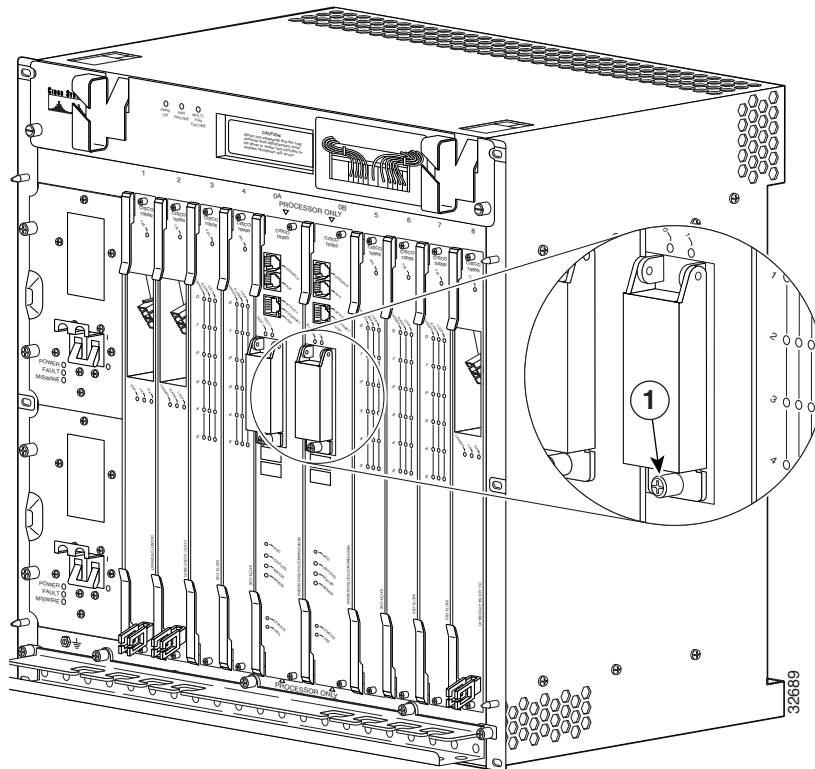

1	Captive screw
---	---------------

**Step 5** Close the cover and tighten the captive screw (Figure 5-49).

**Step 6** Replace the front cover if necessary (see the “Replacing the Front Cover” section on page 5-6).

## Upgrading SDRAM on the PRE

You can increase the amount of SDRAM in your system configuration by replacing the two dual in-line memory modules (DIMMs) with higher capacity SDRAM. The default SDRAM configuration is 128 MB, and can be upgraded to either 256 MB or 512 MB to meet your needs (Table 5-1).

**Note**

We recommend that you upgrade the SDRAM in both the primary and the secondary PRE in a redundant chassis configuration. The DIMMs that you remove may be used in other compatible equipment and should be stored in an antistatic bag.

**Table 5-1 Available SDRAM Upgrades**

SDRAM Upgrade Options	Cisco Part Number
256 MB SDRAM	ESR-PRE-MEM-256M=
512 MB SDRAM	ESR-PRE-MEM-512M=

**Caution**

To prevent (electrostatic discharge) ESD damage, always wear an ESD-preventive wrist or ankle strap, and handle DIMMs by the edges only. Avoid touching the memory pins or traces (the metal fingers along the connector edge of the DIMM).

The Cisco 10008 router system is hot-swappable, which means you can remove and replace a PRE while the system is operating—if your configuration includes a secondary (redundant) PRE installed in the chassis. The hot-swapping feature allows you to remove or replace a PRE while the system maintains all routing information and ensures session preservation. See the [“Removing and Replacing the PRE”](#) section on page 5-36 to remove the PRE from the chassis.

## Removing and Installing DIMMS

Use the following steps to remove and replace DIMMs in the PRE module

**Caution**

To upgrade SDRAM, you must install identical DIMMs in both DIMM sockets. Do not mix different types of DIMMs.

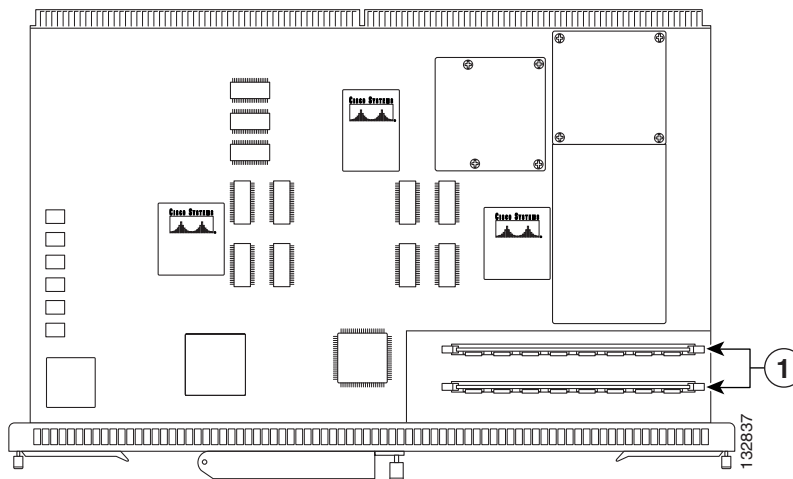
**Figure 5-50 Locating the SDRAM DIMMs**

<b>1</b>	DIMM slots
----------	------------

**Step 1** Remove the PRE according to the instructions in the [“Removing and Replacing the PRE”](#) section on page 5-36.

Place the PRE on an antistatic mat or pad so that the DIMMs are facing up (Figure 5-50).

**Figure 5-51** Removing the DIMM

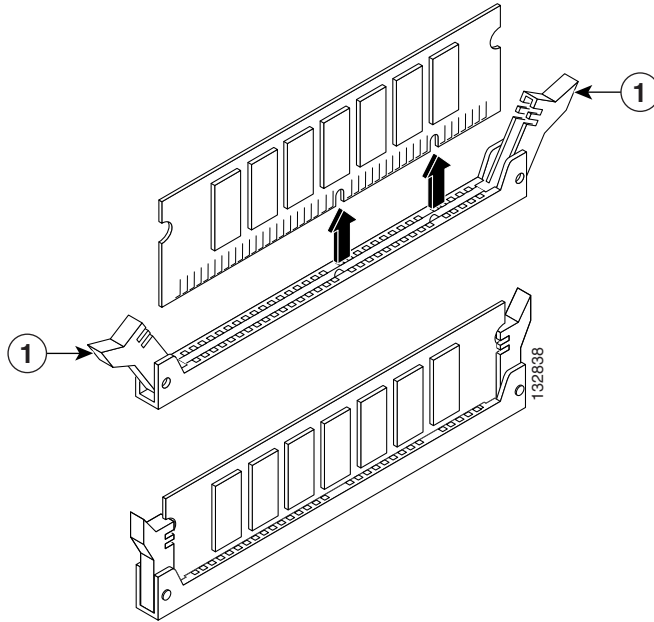

1	Ejector tab	
---	-------------	--

**Step 2** Remove each DIMM from its slot by pushing its ejector tabs out to the side and lifting the DIMM straight up (Figure 5-51).

**Figure 5-52** Properly Handling a DIMM

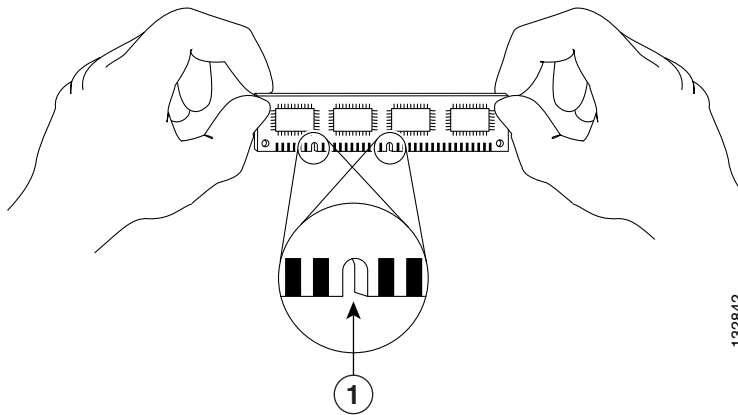

1	Key	
---	-----	--

**Step 3** Remove a new DIMM from its antistatic bag (Figure 5-52).

  
**Caution**

To prevent (electrostatic discharge) ESD damage, always wear an ESD-preventive wrist or ankle strap, and handle DIMMs by the edges only. Avoid touching the memory pins or traces (the metal fingers along the connector edge of the DIMM).

**Figure 5-53** Installing a DIMM

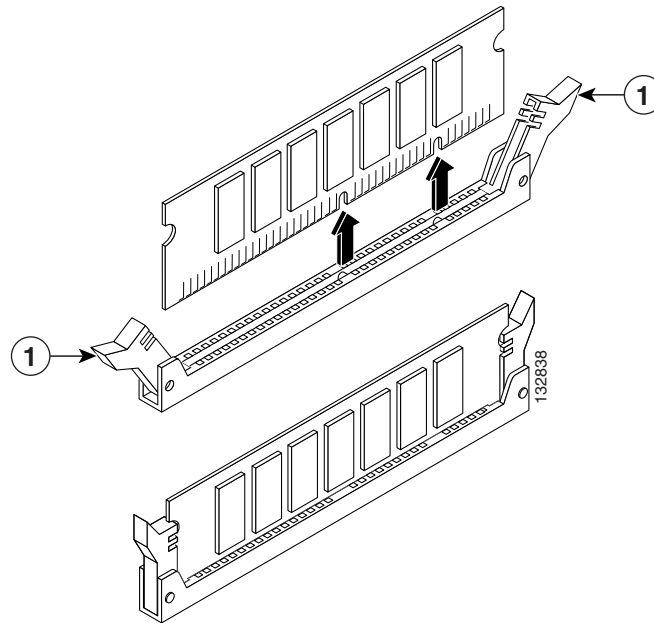

<b>1</b>	Ejector tab
----------	-------------

**Step 4** Install each new DIMM by aligning the keys on the DIMM connector over the DIMM slot, and gently pushing the DIMM into the slot until the ejector tabs snap over each end of the DIMM (Figure 5-53).

  
**Caution**

The DIMMs are keyed and can only be inserted one way. When you insert DIMMs, use firm but not excessive pressure. If you damage a DIMM slot, you must return the PRE to Cisco for repair.

**Step 5** Reinstall the PRE in the chassis after both DIMMs are installed.

## Troubleshooting the DIMM Installation

If the system fails to boot properly, or if the console terminal displays a checksum error after you install the new DIMMs, check the following:

- Each DIMM must be identical in memory size and speed or the system will not operate properly. Do not mix different types of DIMMs.
- Ensure that all DIMMs are installed properly by removing the PRE and checking that:
  - The DIMMs are at the same height and aligned straight up and down
  - The ejector tabs are snapped over each end of the DIMMs (see Figure 5-53)

If the system fails to boot properly after you perform these corrective actions, contact the Cisco Technical Assistance Center (TAC) for additional help. Before you contact TAC, make a note of any error messages, unusual LED states, or any other indications that might help the service representative to identify the problem.



# APPENDIX **A**

## Technical Specifications

---

Table A-1 lists the specifications for the Cisco 10008 router.

**Table A-1** *Cisco 10008 Router System Specifications*

Description	Specifications
Physical specifications	<ul style="list-style-type: none"><li>• Weight: 130 lb (59.02 kg) fully configured chassis</li><li>• Height: 21.75 in. (55.2 cm)</li><li>• Width: 17.5 in. (44.4 cm)</li><li>• Depth: 12.0 in. (30.4 cm)</li><li>• Chassis depth with front cover: 13.75 in. (34.9 cm)</li><li>• Mounting: 19 in. or 23 in. rack mountable (front or mid), 3 units per 7 ft rack</li></ul>
Temperature range	<ul style="list-style-type: none"><li>• Operating: 41 degrees F to 104 degrees F (5 degrees C to 40 degrees C) Short-term operating temperature is limited to 131 degrees F (55 degrees C) in compliance with Bellcore GR-63</li><li>• Storage: -40 degrees F to 158 degrees F (-40 degrees C to 70 degrees C)</li></ul>
Relative humidity	<ul style="list-style-type: none"><li>• Operating—nominal: 5 percent to 85 percent</li><li>• Operating—short term: 5 percent to 90 percent</li><li>• Storage: 5 percent to 95 percent</li></ul>
Operating altitude	-197 ft to 13,123 ft (-60 m to 4000 m)
Airflow	150 cfm <sup>1</sup> through the system blower module 200 cfm through the system blower module if the exhaust temperature exceeds 45 degrees C

Table A-1 Cisco 10008 Router System Specifications (continued)

Description	Specifications
Power entry modules	<p data-bbox="704 312 818 342"><b>DC PEM</b></p> <p data-bbox="704 359 1490 422">Supports up to two separate -48 VDC input feeds by means of built-in two-position terminal blocks</p> <ul data-bbox="719 438 1252 678" style="list-style-type: none"> <li data-bbox="719 438 1195 468">• Part Number: ESR-PWR-DC (Primary)</li> <li data-bbox="751 470 1252 499">Part Number: ESR-PWR-DC\R (Redundant)</li> <li data-bbox="719 516 1133 546">• DC input voltage: -48 to -60 VDC</li> <li data-bbox="719 562 1146 592">• DC input current: 20A @ -48 VDC</li> <li data-bbox="719 609 1190 638">• Power consumption: 1200W maximum</li> <li data-bbox="719 655 1094 684">• Heat dissipation: 3768 Btu<sup>2</sup>/hr</li> </ul> <p data-bbox="704 695 818 724"><b>AC PEM</b></p> <ul data-bbox="719 741 1409 1024" style="list-style-type: none"> <li data-bbox="719 741 1195 770">• Part Number: ESR-PWR-AC (Primary)</li> <li data-bbox="751 772 1252 802">Part Number: ESR-PWR-AC\R (Redundant)</li> <li data-bbox="719 819 1203 848">• AC inlet power connector: IEC 320 C20</li> <li data-bbox="719 865 1409 894">• AC input voltage: 100 to 240 VAC, 50/60 Hz, single phase</li> <li data-bbox="719 911 1062 940">• AC input current: 15 to 7 A</li> <li data-bbox="719 957 1190 987">• Power consumption: 1400W maximum</li> <li data-bbox="719 1003 1086 1033">• Heat dissipation: 4760 Btu/hr</li> </ul>



**Table A-1 Cisco 10008 Router System Specifications (continued)**

Description	Specifications
Performance routing engine (PRE)	<ul style="list-style-type: none"> <li>• Part Number: ESR-PRE1 (Primary) Part Number: ESR-PRE1/R (Redundant)</li> <li>• Power: 80W</li> <li>• Max per chassis: 2</li> <li>• Weight: 7.5 lb (3.41 kg) Height: 16.0 in. (40.64 cm) Depth: 9.97 in. (25.32 cm) Width: 1.91 in. (4.84 cm)</li> </ul> <p>Three Interface ports:</p> <ul style="list-style-type: none"> <li>• RJ-45 IEEE 802.3 Ethernet 100BASE-T</li> <li>• RJ-45 auxiliary (AUX) port for modem access</li> <li>• RJ-45 console (CON) port for terminal access</li> </ul> <p>Two PCMCIA Flash card slots:</p> <ul style="list-style-type: none"> <li>• Slot 0</li> <li>• Slot 1</li> </ul>
PRE PCMCIA Flash disk card options	<ul style="list-style-type: none"> <li>• 40 MB—Part Number: ESR-PRE-MEM-FD40</li> <li>• 128 MB—Part Number: ESR-PRE-MEM-FD128</li> </ul>
PRE DRAM memory options	<ul style="list-style-type: none"> <li>• 256 MB—Part Number: ESR-PRE-MEM-256M</li> <li>• 512 MB—Part Number: ESR-PRE-MEM-512M</li> </ul>

1. cfm = cubic feet per minute

2. Btu = British thermal units

For Specifications for Operating and Nonoperating Environments, see [“Site Environmental Requirements” section on page 2-2](#).

For technical specifications for the Cisco 10008 line cards, see the [Cisco 10000 Line Card Hardware Installation Guide](#).

For regulatory compliance and safety information, see the [Regulatory Compliance and Safety Information for the Cisco 10000 Series Routers](#) document.





## APPENDIX **B**

### Repacking the Box

---

If your system is damaged, you must repack it for return shipment. Use the original shipping containers. [Figure B-1](#) shows an exploded view of the system and packing materials.

To return or move the Cisco 10008 router to a different location, follow these instructions for repacking the system, using the original packaging material:

**Figure B-1**      *Cisco 10008 System and Packing Material*

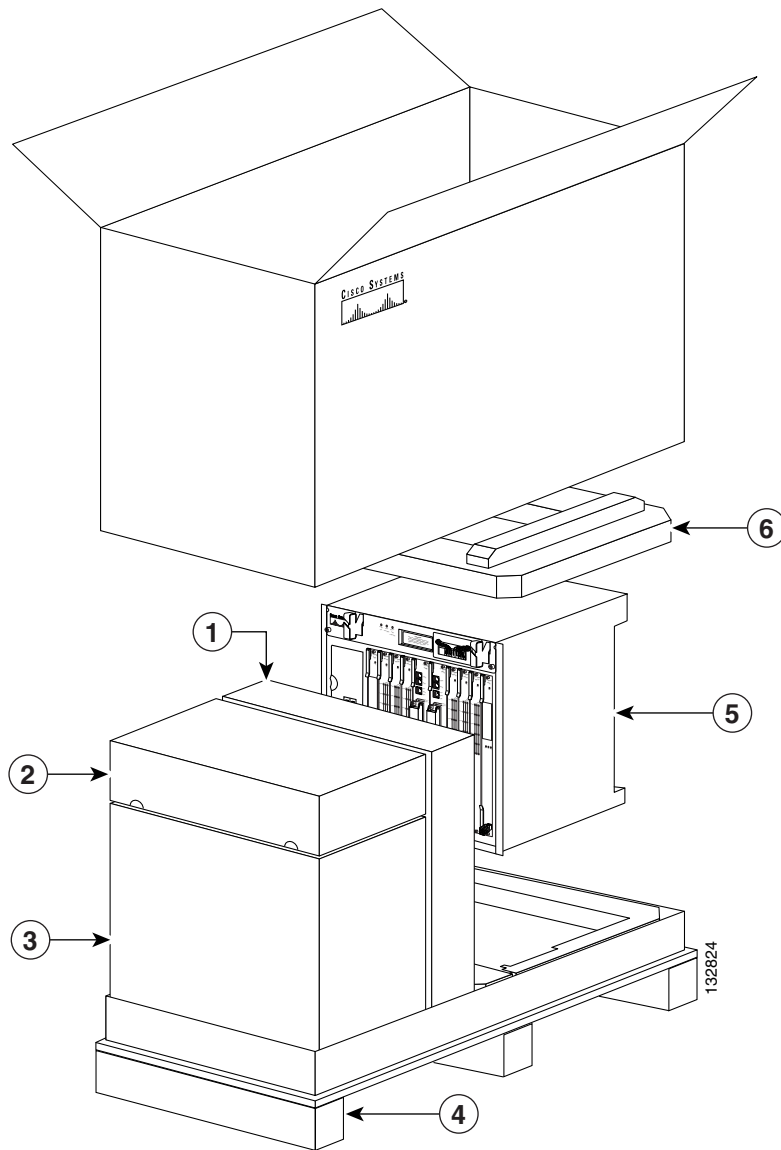

1	Front cover (bezel)	4	Bottom pallet
2	Accessory box	5	Top packing material
3	Filler box (empty)	6	Cisco 10000 router

- Step 1** Place the bottom packing material section inside the bottom of the shipping container.
- Step 2** Use at least two people to place the Cisco 10008 chassis inside the container. Be sure that the chassis is positioned correctly before you lower it inside the container (see [Figure B-1](#)).
- Step 3** Place the top packing material over the top of the Cisco 10008 chassis (see [Figure B-1](#)).
- Step 4** Place both accessory boxes inside the cutouts in the top section of the packing material (see [Figure B-1](#)).

Figure B-2 Cisco 10008 System Package

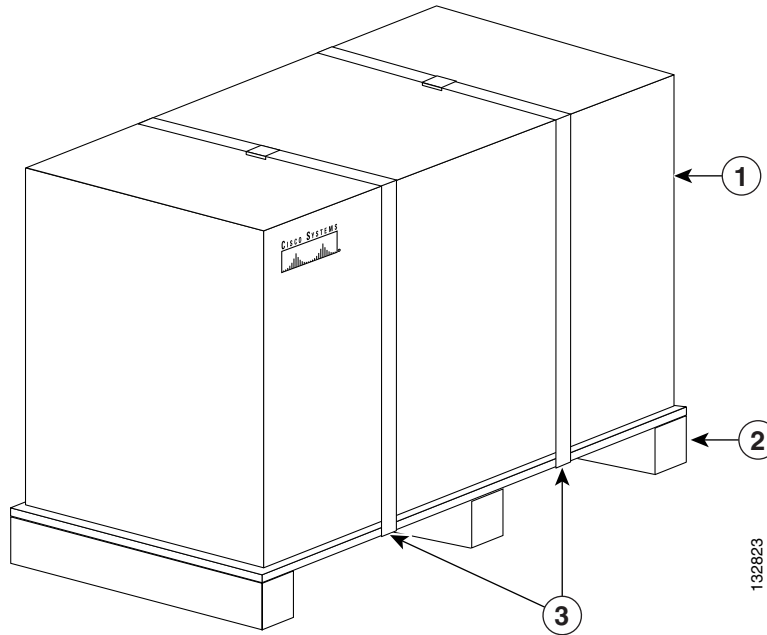

<b>1</b>	Carton	<b>3</b>	Packing straps
<b>2</b>	Pallet		

**Step 5** Fold the outside carton down over the top of the accessory boxes and seal with packing tape (Figure B-2).

**Step 6** Wrap two packaging straps tightly around the top and bottom of the package to hold the outside carton and the bottom pallet (Figure B-2).



**Caution** Do not use tape to hold the outside carton to the bottom pallet. Packaging straps must be used.





## GLOSSARY

---

### Symbols

- 1+1 APS** See [APS](#).
- 10BaseT** 10-Mbps baseband Ethernet specification using two pairs of twisted-pair cabling (Category 3, 4, or 5): one pair for transmitting data and the other for receiving data. 10BaseT, which is part of the IEEE 802.3 specification, has a distance limit of approximately 328 feet (100 meters) per segment. See also [IEEE 802.3](#) and [Ethernet](#).
- 100BaseT** 100-Mbps baseband Fast Ethernet specification using UTP wiring. Like the 10BaseT technology on which it is based, 100BaseT sends link pulses over the network segment when no traffic is present. However, these link pulses contain more information than those used in 10BaseT. The 100BaseT specification is based on the IEEE 802.3 standard. See also [10BaseT](#), [Fast Ethernet](#), and [IEEE 802.3](#).
- 1000BaseLX/LH** 1000-Mbps gigabit Ethernet specification using two strands of multimode or single mode fiber-optic cable per link. To guarantee proper signal recovery, a 1000BaseLX/LH link cannot exceed 1804 feet (550 meters) in length over multimode fiber or 32,810 feet (10 km) in length over single mode fiber. Based on the IEEE 802.3 standard with reach over single mode fiber extended from 5 km to 10 km. See also [1000BaseSX](#), [1000BaseZX](#), [Gigabit Ethernet](#), and [IEEE 802.3](#).
- 1000BaseSX** 1000-Mbps gigabit Ethernet specification using two strands of multimode fiber-optic cable per link. To guarantee proper signal recovery, a 1000BaseSX link cannot exceed 1804 feet (550 meters) in length. The 1000Base SX specification is based on the IEEE 802.3 standard. See also [1000BaseLX/LH](#), [1000BaseZX](#), [Gigabit Ethernet](#), and [IEEE 802.3](#).
- 1000BaseX** 1000-Mbps gigabit Ethernet specification that refers to the 1000BaseCX, 1000BaseSX, and 1000BaseLX standards for gigabit Ethernet over fiber-optic cabling. The 1000BaseX specification is based on the IEEE 802.3 standard. See also [1000BaseSX](#), [1000BaseLX/LH](#), [1000BaseZX](#), [Gigabit Ethernet](#), and [IEEE 802.3](#).
- 1000BaseZX** 1000-Mbps gigabit Ethernet specification using two strands of single mode fiber-optic cable per link. To guarantee proper signal recovery, a 1000BaseZX link cannot be longer than 62.1 mi (100 km). This is a Cisco specification. See also [1000BaseSX](#), [1000BaseLX/LH](#), [Gigabit Ethernet](#), and [IEEE 802.3](#).
- 802.x** A set of IEEE standards for the definition of LAN protocols.

---

**A**

- AAL** ATM adaptation layer. Service-dependent sublayer of the data link layer. The AAL accepts data from different applications and presents it to the ATM layer in the form of 48-byte ATM payload segments. AALs consist of two sublayers: the convergence sublayer and the segmentation and reassembly sublayer. Four types of AAL recommended by the ITU-T are AAL1, AAL2, AAL3/4, and AAL5; the Cisco 10008 router uses AAL5.
- Access list** List kept by routers to control access to or from the router for a number of services. For example, access lists can be used to prevent packets with a certain IP address from leaving a particular interface on the router.
- Add drop Multiplexer** See [ADM](#).
- ADM** Add Drop Multiplexer. A multiplexer that allows a signal to be added into or dropped out of a SONET span. See also [SONET](#).
- Alarm** A status condition that shows that a module or port is experiencing an abnormal operating condition. See also [Critical alarm](#), [Major alarm](#), and [Minor alarm](#).
- Application-specific integrated circuit** See [ASIC](#).
- APS** Automatic Protection Switching. A SONET switching mechanism that achieves network resiliency by automatically switching from a primary circuit to a secondary circuit. This switching process occurs if the primary circuit fails or if the error rate on the primary line exceeds a set threshold. The Cisco 10008 router supports 1+1 APS, which provides permanent electrical bridging to the service and protection equipment, placed at both ends of the circuit.
- ASIC** Application-specific integrated circuit. A chip that is built for a specific application.
- Asynchronous Transfer Mode** See [ATM](#).
- ATM** Asynchronous Transfer Mode. International standard for cell relay in which multiple service types (such as voice, video, or data) are conveyed in fixed-length (53-byte) cells. Fixed-length cells allow cell processing to occur in hardware, thereby reducing transit delays. ATM is designed to take advantage of high-speed transmission media such as E3, SONET, and T3.
- Authentication** In security, the verification of the identity of a person or process.
- Automatic protection switching** See [APS](#).
- Alarm** A status condition that shows that a module or port is experiencing an abnormal operating condition. See also [Critical alarm](#), [Major alarm](#), and [Minor alarm](#).



---

<b>B</b>	
<b>Backplane</b>	The circuit board at the back of the chassis that all components plug into. It provides the physical connection between an interface processor or line card, and the data and power distribution buses inside a chassis.
<b>Bellcore</b>	Bell Communications Research. Former name of the organization that performs research and development on behalf of the Regional Bell Operating Companies (RBOCs). Bellcore is now called Telcordia.
<b>BER</b>	Bit error rate. The ratio of received bits that contain errors.
<b>BGP</b>	Border Gateway Protocol. An interdomain routing protocol that replaces EGP. BGP exchanges connection information with other BGP systems. It is defined by RFC 1163.
<b>Bit error rate</b>	See <a href="#">BER</a> .
<b>Border Gateway Protocol</b>	See <a href="#">BGP</a> .
<b>Broadcast</b>	Data packet that is sent to all nodes on a network. Broadcasts are identified by a broadcast address. Compare with <a href="#">Multicast</a> and <a href="#">Unicast</a> .

---

<b>C</b>	
<b>CCITT</b>	Consultative Committee for International Telegraph and Telephone. International organization responsible for the development of communications standards. Now called the ITU-T. (See <a href="#">ITU-T</a> .)
<b>CEF</b>	Cisco Express Forwarding. An advanced Layer 3 IP switching technology designed for high-performance, highly resilient Layer 3 IP backbone switching. CEF optimizes network performance and scalability for networks with large and dynamic traffic patterns, such as the Internet, on networks characterized by intensive Web-based applications or interactive sessions.
<b>Central Office</b>	See <a href="#">CO</a> .
<b>Channel</b>	Communication path. Multiple channels can be multiplexed over a single cable in certain environments.
<b>Cisco Express Forwarding</b>	See <a href="#">CEF</a> .
<b>Cisco IOS</b>	Cisco system software that provides common functionality, scalability, and security for Cisco products. Cisco IOS allows centralized, integrated, and automated installation and management of internetworks, while ensuring support for a wide variety of protocols, media, services, and platforms.
<b>Clear channel DS3</b>	A framed DS3 signal which is not multiplexed from 28 DS1 signals. Sometimes referred to as unchannelized DS3.
<b>CLI</b>	Command line interface. Interface that allows the user to interact with the operating system by entering commands and optional arguments at the command prompt.
<b>CO</b>	Central office. The local telephone company office to which all local loops in a given area connect and in which circuit switching of subscriber lines occurs.

<b>Command Line Interface</b>	See <a href="#">CLI</a> .
<b>Console</b>	Data terminal equipment (DTE) through which commands are entered into a host.
<b>Critical alarm</b>	An alarm condition that might affect most or all subscribers that connect to the reporting node. To obtain more information about a problem, use the <b>show facility-alarm status</b> command. See also <a href="#">Major alarm</a> and <a href="#">Minor alarm</a> .

---

## D

<b>Data terminal equipment</b>	See <a href="#">DTE</a> .
<b>DCE</b>	Data circuit-terminating equipment (ITU-T expansion). Devices and connections of a communications network that comprise the network end of the user-to-network interface. The DCE provides a physical connection to the network, forwards traffic, and provides a clocking signal used to synchronize data transmission between DCE and DTE devices. Modems and interface cards are examples of DCE. Compare with <a href="#">DTE</a> .
<b>DRAM</b>	Dynamic random access memory. RAM that stores information in capacitors that must be periodically refreshed. Delays can occur because DRAMs are inaccessible to the processor when refreshing their contents. However, DRAMs are less complex and have greater capacity than SRAMs. See also <a href="#">SRAM</a> .
<b>DS0</b>	Digital signal level 0. Framing specification used in transmitting digital signals over a single channel at 64 kbps on a T1 facility. Compare with <a href="#">DS1</a> and <a href="#">DS3</a> .
<b>DS1</b>	Digital signal level 1. Framing specification used in transmitting digital signals at 1.544 Mbps on a T1 facility (in the United States) or at 2.108 Mbps on an E1 facility (in Europe). Compare with <a href="#">DS0</a> and <a href="#">DS3</a> .
<b>DS3</b>	Digital signal level 3. Framing specification used for transmitting digital signals at 44.736 Mbps on a T3 facility. Compare with <a href="#">DS0</a> and <a href="#">DS1</a> .
<b>DSU</b>	Data Service Unit. Device used in digital transmission that adapts the physical interface on a DTE device to a transmission facility such as T1 or E1. The DSU is also responsible for such functions as signal timing. Often used with CSU, as in CSU/DSU.
<b>DTE</b>	Data terminal equipment. Device at the user end of a user-network interface that serves as a data source, destination, or both. DTE connects to a data network through a DCE device (for example, a modem) and typically uses clocking signals generated by the DCE. DTE includes devices such as computers, protocol translators, and multiplexers.
<b>Dynamic random access memory</b>	See <a href="#">DRAM</a> .

---

## E

<b>E1</b>	Wide-area digital transmission scheme used predominantly in Europe that carries data at a rate of 2.048 Mbps. E1 lines can be leased for private use from common carriers. Compare with T1; see also DS1.
-----------	---

<b>Edge Services Router</b>	See <a href="#">ESR</a> .
<b>Electromagnetic interference</b>	See <a href="#">EMI</a> .
<b>Electrostatic discharge</b>	See <a href="#">ESD</a> .
<b>EMI</b>	Electromagnetic interference. Interference by electromagnetic signals that can cause reduced data integrity and increased error rates on transmission channels.
<b>EMP</b>	Electromagnetic pulse. Caused by lightning and other high-energy phenomena. Capable of coupling enough energy into unshielded conductors to destroy electronic devices.
<b>ESD</b>	Electrostatic discharge. Discharge of stored static electricity that can damage electronic equipment and impair electrical circuitry, resulting in complete or intermittent failures.
<b>ESR</b>	Edge Services Router. A router that aggregates and routes traffic from thousands of low- and medium-bandwidth subscriber connections into a few high-bandwidth connections to the Internet core.
<b>Ethernet</b>	Baseband LAN specification. Ethernet networks use CSMA/CD and run over a variety of cable types at 10 Mbps, 100 Mbps, and 1000 Mbps. Ethernet is similar to the IEEE 802.3 series of standards. See also <a href="#">Fast Ethernet</a> , <a href="#">Gigabit Ethernet</a> , <a href="#">IEEE 802.3</a> .

---

## F

<b>Fast Ethernet</b>	Any of a number of 100-Mbps Ethernet specifications. Fast Ethernet offers a speed increase 10 times that of the 10BaseT Ethernet specification, while preserving qualities such as frame format, MAC mechanisms, and MTU. Existing 10BaseT applications and network management tools can be used on Fast Ethernet networks. The Fast Ethernet specification is based on an extension to the IEEE 802.3 specification. Compare with <a href="#">Ethernet</a> and <a href="#">Gigabit Ethernet</a> . See also <a href="#">100BaseT</a> and <a href="#">IEEE 802.3</a> .
<b>Fiber-optic cable</b>	Physical medium capable of conducting modulated light transmission. Compared with other transmission media, fiber-optic cable is more expensive, but it is not susceptible to electromagnetic interference and is capable of higher data rates. Sometimes called optical fiber.
<b>Field-replaceable unit</b>	See <a href="#">FRU</a> .
<b>Flash memory</b>	Nonvolatile storage that can be electrically erased and reprogrammed so that software images can be stored, booted, and rewritten as necessary. Flash memory was developed by Intel and is licensed to other semiconductor companies.
<b>Frame Relay</b>	Industry-standard, switched data link layer protocol that handles multiple virtual circuits using HDLC encapsulation between connected devices. Frame Relay is more efficient than X.25, the protocol for which it is generally considered a replacement.
<b>FRU</b>	Field replaceable unit. A component that can be removed from a network device and replaced in the field. Line cards, power modules, and fan modules are typically FRUs.

---

**G**

- GBIC** Gigabit Ethernet converter. An interface module used by gigabit Ethernet and Fibre Channel to convert the serial electrical signals to the transmission medium's physical layer signalling, which is typically optical. GBIC modules can be hot swapped and contain ID and system information that a switch or router can use to determine the network device's capabilities. Different GBICs handle different types of fiber cable. See [1000BaseLX/LH](#), [1000BaseSX](#), and [1000BaseZX](#).
- Gigabit Ethernet** Gigabit Ethernet. Ethernet running at a transmission speed of 1 billion bits per second.
- Gigabit Interface Converter** See [GBIC](#).

---

**H**

- Hot swapping** Feature that permits the addition, replacement, or removal of cards without interrupting the system power, entering console commands, or causing other software or interfaces to shut down. Sometimes called online insertion and removal (OIR).

---

**I**

- IEEE** Institute of Electrical and Electronics Engineers. Professional organization whose activities include the development of communications and network standards. IEEE LAN standards are the currently predominant LAN standards.
- IEEE 802.3** IEEE LAN protocol that specifies an implementation of the physical layer and the MAC sublayer of the data link layer. IEEE 802.3 uses CSMA/CD access at a variety of speeds over a variety of physical media. Extensions to the IEEE 802.3 standard specify implementations for Fast Ethernet and gigabit Ethernet.
- Institute of Electrical and Electronics Engineers** See [IEEE](#).
- Intermediate reach** See [IR](#).
- Internet service provider** See [ISP](#).
- IOS** Internet Operating System. See [Cisco IOS](#).
- IP** Internet Protocol. Network layer protocol in the TCP/IP stack offering a connectionless internetwork service. IP provides features for addressing, type-of-service specification, fragmentation and reassembly, and security. Defined in RFC 791.
- IP multicast** Routing technique that allows IP traffic to be propagated from one source to a number of destinations or from many sources to many destinations. Rather than sending one packet to each destination, one packet is sent to a multicast group identified by a single IP destination group address.

<b>IR</b>	Intermediate reach. SONET/SDH specification for transmit power and receive sensitivity that achieves a 9.3-mile (15-km) reach.
<b>ISP</b>	Internet Service Provider. A company that provides Internet access to other companies and individuals.
<b>ITU-T</b>	International Telecommunication Union Telecommunication Standardization Sector. International body that develops worldwide standards for telecommunications technologies. The ITU-T carries out the functions of the former CCITT.

---

**L**

<b>LAN</b>	Local-area network. High-speed, low-error data network covering a relatively small geographic area (up to a few thousand meters). LANs connect workstations, peripherals, terminals, and other devices in a single building or some other geographically limited area. LAN standards specify cabling and signaling at the physical and data link layers of the OSI model. Ethernet, FDDI, and Token Ring are widely used LAN technologies. Compare with <a href="#">MAN</a> and <a href="#">WAN</a> .
<b>Line card</b>	Any I/O card that can be inserted in a modular chassis.
<b>LMI</b>	Local Management Interface. A set of enhancements to the basic Frame Relay specification. LMI includes support for a keepalive mechanism, which verifies that data is flowing; a multicast mechanism, which provides the network server with its local DLCI and the multicast DLCI; global addressing, which gives DLCIs global rather than local significance in Frame Relay networks; and a status mechanism, which provides an on-going status report on the DLCIs known to the switch. Known as LMT in ANSI terminology.
<b>Local-area network</b>	See <a href="#">LAN</a> .
<b>Loopback test</b>	A test in which signals are sent and then directed back toward their source from some point along the communications path. Loopback tests are often used to test network interface usability.
<b>LOS</b>	Loss of signal. A SONET port status indicator that activates when an LOS defect occurs and does not clear throughout the alarm integration period, which is typically 2.5 seconds. An LOS defect occurs when the OC-3 port receives all zeros for 20 microseconds (+.3 ms). This occurrence begins the alarm integration period. If this period elapses without the detection of two consecutive frames in which there are no 20-ms periods of signal loss, the LOS indicator activates. The LOS indicator clears when an LOS defect is not detected for an interval equal to the alarm deactivation period (typically 10 seconds).

---

**M**

<b>M13</b>	Generic term for equipment that multiplexes DS1s into DS3s. Sometimes used to describe a specific DS3 multiplex format. Some standards use this term to describe a synchronous multiplexing format also known as SYNTRAN. In many cases M13 does not refer to the SYNTRAN format, but instead refers to the format also known as M23.
<b>M23</b>	A method of multiplexing four DS1 signals into a DS2 signal, then multiplexing seven DS2 signals into a DS3 signal.

<b>MAC</b>	Media Access Control. Lower of the two sublayers of the data link layer defined by the IEEE. The MAC sublayer handles access to shared media.
<b>MAC address</b>	Standardized data link layer address that is required for each port or device that connects to a LAN. Other devices in the network use these addresses to locate specific ports in the network, and to create and update routing tables and data structures. MAC addresses are 6 bytes long and are controlled by the IEEE. Also known as a hardware address, MAC-layer address, or physical address.
<b>Major alarm</b>	One of a group of alarm conditions that are considered the second most severe of all reportable alarms. Major alarms affect several subscribers who connect to the reporting node. You can use the <b>show facility-alarm status</b> IOS command to obtain more information about the problem. See also <a href="#">Critical alarm</a> and <a href="#">Minor alarm</a> .
<b>MAN</b>	Metropolitan-area network. A network that spans a metropolitan area. Generally, a MAN spans a larger geographic area than a LAN, but a smaller geographic area than a WAN. Compare with <a href="#">LAN</a> and <a href="#">WAN</a> .
<b>Management Information Base</b>	See <a href="#">MIB</a> .
<b>Media Access Control</b>	See <a href="#">MAC</a> .
<b>Metropolitan-area network</b>	See <a href="#">MAN</a> .
<b>MIB</b>	Management Information Base. Database of network management information that is used and maintained by a network management protocol such as SNMP or CMIP. The value of a MIB object can be changed or retrieved using SNMP or CMIP commands, usually through a GUI-based network management system. MIB objects are organized in a tree structure that includes public (standard) and private (proprietary) branches.
<b>Minor alarm</b>	One of a group of alarm conditions that are considered the third most severe of all reportable alarms. Minor alarms affect a single or small number of subscribers who connect to the reporting node. You can use the <b>show facility-alarm status</b> IOS command to obtain more information about the problem. See also <a href="#">Critical alarm</a> and <a href="#">Major alarm</a> .
<b>MLP</b>	Multilink Point-to-Point Protocol. A method of splitting, recombining, and sequencing datagrams across multiple logical data links.
<b>MMF</b>	Multimode fiber. Optical fiber supporting propagation of multiple frequencies of light. See also <a href="#">Single-mode fiber</a> .
<b>MPLS</b>	Multiprotocol Label Switching. An emerging industry standard upon which tag switching is based.
<b>Multicast</b>	Single packets copied by the network and sent to a specific subset of network addresses. These addresses are specified in the Destination Address field. Compare with <a href="#">Broadcast</a> and <a href="#">Unicast</a> .
<b>Multilink Point-to-Point</b>	See <a href="#">MLP</a> .
<b>Multimode fiber</b>	See <a href="#">MMF</a> .

**Multiplexing** An activity in which multiple logical signals are transmitted simultaneously across a single physical channel.

**Multiprotocol Label Switching** See [MPLS](#).

---

## N

**NEBS** Network Equipment Building Systems. The Telcordia (formerly Bellcore) requirements for equipment deployed in a central office environment. Covers spatial, hardware, crafts person interface, thermal, fire resistance, handling and transportation, earthquake and vibration, airborne contaminants, grounding, acoustical noise, illumination, EMC, and ESD requirements.

**Network Equipment Building Systems** See [NEBS](#).

**Network termination unit** See [NTU](#).

**Nonvolatile RAM** See [NVRAM](#).

**NTU** Network terminating unit. The network equipment that connects directly to the data terminal equipment.

**NVRAM** Nonvolatile RAM. RAM that retains its contents when a unit is powered off.

---

## O

**OC** Optical carrier. A series of physical protocols (OC-1, OC-2, OC-3, and so forth), defined for SONET optical signal transmissions. OC signal levels put STS frames onto fiber-optic lines at a variety of speeds. The base rate is 51.84 Mbps (OC-1); each signal level thereafter operates at a speed divisible by that number (thus, OC-3 runs at 155.52 Mbps).

**ODL** Optical data link.

**OIR** Online insertion and removal. Feature that permits the addition, replacement, or removal of cards without interrupting the system power, entering console commands, or causing other software or interfaces to shut down. Same as hot swapping.

**Online insertion and removal** See [OIR](#).

**Optical carrier** See [OC](#).

**Optical fiber** See [Fiber-optic cable](#).

---

**P**

<b>Packet</b>	Logical grouping of information that includes a header containing control information and (usually) user data. Packets are most often used to refer to network layer units of data. The terms datagram, frame, message, and segment are also used to describe logical information groupings at various layers of the OSI reference model and in various technology circles.
<b>Packet Over SONET</b>	See <a href="#">POS</a> .
<b>Packet switching</b>	Networking method in which nodes share bandwidth with each other by sending packets.
<b>Parallel Express Forwarding</b>	See <a href="#">PXF Network Processors</a> .
<b>PCMCIA Flash disk card</b>	A portable (credit-card size), nonvolatile storage device. PCMCIA Flash disk cards use Flash technology to store data. PCMCIA stands for Personal Computer Memory Card International Association, which sets the standard for this technology. Also called PC card.
<b>PEM</b>	Power entry module. A hardware module that distributes power to the chassis.
<b>Performance Routing Engine</b>	See <a href="#">PRE</a> .
<b>Point of Presence</b>	See <a href="#">POP</a> .
<b>Point-to-Point Protocol</b>	See <a href="#">PPP</a> .
<b>POP</b>	Point of presence. A physical location where an interexchange carrier installed equipment to interconnect with a local exchange carrier.
<b>POS</b>	Packet Over SONET. A high-speed means of transmitting data over a SONET fiber-optic transmission system through a direct fiber connection to a data switch or router. POS is a point-to-point dedicated leased-line approach intended purely for high-speed data applications. POS allows a user organization to pass data in its native format, without the addition of any significant level of overhead in the form of signaling and control information.
<b>POST</b>	Power-on self test. A set of hardware diagnostics that runs on a hardware device when that device is powered on.
<b>Power Entry Module</b>	See <a href="#">PEM</a> .
<b>Power-on self test</b>	See <a href="#">POST</a> .
<b>PPP</b>	Point-to-Point Protocol. Provides router-to-router and host-to-network connections over synchronous and asynchronous circuits.
<b>PRE</b>	Performance routing engine. The central routing unit for the Cisco 10008 router. The PRE performs all Layer 2 and Layer 3 packet manipulation related to routing and forwarding through the Cisco 10008 router. Dual PREs can be configured in a single chassis for redundancy. See also <a href="#">PXF Network Processors</a> .
<b>PXF Network Processors</b>	Parallel eXpress Forwarding network processors. A pair of programmable ASICs that perform parallel processing to support high performance Layer 3 forwarding.



---

**Q**

- QoS** Quality of service. A measure of performance for a transmission system that reflects its transmission quality and service availability.
- QPPB** QoS Policy Propagation by BGP. A feature that classifies packets by IP precedence based on BGP community lists, BGP autonomous system paths, and access lists. After a packet is classified, other quality of service features such as committed access rate (CAR) and Weighted Random Early Detection (WRED) can specify and enforce policies to fit a business model.
- Quality of Service** See [QoS](#).

---

**R**

- RAM** Random-access memory. Volatile memory that can be read and written by a microprocessor.
- Random Access Memory** See [RAM](#).
- Read only memory** See [ROM](#).
- Redundancy** In internetworking, the duplication of devices, services, or connections so that, in the event of a failure, the redundant devices, services, or connections can perform the work of those that failed.
- Remote monitoring** See [RMON](#).
- Request for comments** See [RFC](#).
- RFC** Request for comments. A document series used as the primary means for communicating information about the Internet. Some RFCs are designated by the IAB as Internet standards. Most RFCs document protocol specifications such as Telnet and FTP, but some are humorous or historical. RFCs are available online from numerous sources.
- RMON** Remote Monitoring. MIB agent specification described in RFC 1271 that defines functions for the remote monitoring of networked devices. The RMON specification provides numerous monitoring, problem detection, and reporting capabilities.
- ROM** Read only memory. Nonvolatile memory that can be read, but not written, by the microprocessor.

---

**S**

- SAR** Segmentation and reassembly. One of the two sublayers of the AAL common part convergence sublayer, responsible for dividing (at the source) and reassembling (at the destination) the protocol data units (PDUs) passed from the convergence sublayer. The SAR sublayer takes the PDUs processed by the convergence sublayer and, after dividing them into 48-byte pieces of payload data, passes them to the ATM layer for further processing. See also AAL.
- Short reach** See [SR](#).

<b>Simple Network Management Protocol</b>	See <a href="#">SNMP</a> .
<b>Single-mode fiber</b>	See <a href="#">SMF</a> .
<b>SMF</b>	Single-mode fiber. Fiber-optic cabling with a narrow core that allows light to enter only at a single angle. Such cabling has higher bandwidth than multimode fiber, but requires a light source with a narrow spectral width (for example, a laser). Also called monomode fiber. See also <a href="#">Multimode fiber</a> .
<b>SNMP</b>	Simple Network Management Protocol. Network management protocol used almost exclusively in TCP/IP networks. SNMP provides a means to monitor and control network devices, and to manage configurations, statistics collection, performance, and security. See also <a href="#">SNMP2</a> .
<b>SNMP2</b>	SNMP Version 2. Version 2 of the network management protocol. SNMP2 supports centralized as well as distributed network management strategies, and includes improvements in the SMI, protocol operations, management architecture, and security. See also <a href="#">SNMP</a> .
<b>SONET</b>	Synchronous Optical Network. High-speed synchronous network specification developed by Bellcore and designed to run on optical fiber. STS-1 is the basic building block of SONET. It was approved as an international standard in 1988.
<b>SR</b>	Short reach. SONET/SDH specification for transmit power and receive sensitivity that achieves a 1.2-mile (2 km) reach.
<b>SRAM</b>	A type of RAM that retains its contents for as long as power is supplied. SRAM does not require constant refreshing, like DRAM. Compare with <a href="#">DRAM</a> .
<b>Subrate DS3</b>	A generic term to describe a process in which the bandwidth of a clear channel DS3 is limited to a lower rate. Several proprietary formats exist.
<b>Synchronous Optical Network</b>	See <a href="#">SONET</a> .

---

<b>T</b>	
<b>T1</b>	Digital WAN carrier facility. T1 transmits DS1-formatted data at 1.544 Mbps through the telephone switching network.
<b>T3</b>	Digital WAN carrier facility. T3 transmits DS3-formatted data at 44.736 Mbps through the telephone switching network.
<b>TAC</b>	A Cisco Technical Assistance Center. There are four TACs worldwide.
<b>TACACS</b>	Terminal Access Controller Access Control System. Authentication protocol, developed by the DDN community, that provides remote access authentication and related services, such as event logging. User passwords are administered in a central database rather than in individual routers, providing an easily scalable network security solution.
<b>TACACS+</b>	Terminal Access Controller Access Control System Plus. Proprietary Cisco enhancement to Terminal Access Controller Access Control System (TACACS). Provides additional support for authentication, authorization, and accounting.

<b>TDM</b>	Time-division multiplexing. A technique in which information from multiple channels can be allocated bandwidth on a single wire based on preassigned time slots. Bandwidth is allocated to each channel regardless of whether the station has data to transmit.
<b>Telcordia</b>	Organization that performs research and development on behalf of the Regional Bell Operating Companies (RBOCs). Formerly called Bellcore.
<b>TELNET</b>	Standard terminal emulation protocol in the TCP/IP protocol stack. Telnet is used for remote terminal connection, enabling users to log in to remote systems and use resources as if they were connected to a local system. Telnet is defined in RFC 854.
<b>Terminal Access Controller Access Control System Plus</b>	See <a href="#">TACACS+</a> .
<b>TFTP</b>	Trivial File Transfer Protocol. Simplified version of FTP that allows files to be transferred from one computer to another over a network.
<b>Time-division multiplexing</b>	See <a href="#">TDM</a> .
<b>Traffic management</b>	A technique for avoiding congestion and shaping and policing traffic. It allows links to operate at high levels of utilization by scaling back lower-priority, delay-tolerant traffic at the edge of the network when congestion begins to occur.
<b>Traffic shaping</b>	Use of queues to limit surges that can congest a network. Data is buffered and then sent into the network in regulated amounts to ensure that the traffic will fit within the promised traffic envelope for the particular connection. Traffic shaping is used in ATM, Frame Relay, and other types of networks. Also known as metering, shaping, or smoothing.

---

**U**

**Unchannelized DS3** See [Clear channel DS3](#).

**Unicast** A message sent to a single network destination. Compare with [Broadcast](#) and [Multicast](#).

---

**V**

**Virtual Private Network** See [VPN](#).

**VLAN** Virtual LAN. A group of devices on one or more LANs that are configured (using management software) so that they can communicate as if they were attached to the same wire, when in fact they are located on a number of different LAN segments. Because VLANs are based on logical instead of physical connections, they are extremely flexible.

**VoIP** Voice over IP. Voice over IP enables a router to carry voice traffic (for example, telephone calls and faxes) over an IP network.

**VPN** Virtual private network. A secure, end-to-end private network constructed over a third-party or public network such as the Internet.

**VT-*n*** Virtual tributary level *n*. The SONET format for mapping a lower-rate signal into a SONET payload. For example, VT-1.5 is used to transport a DS1 signal. See also [DS1](#) and [SONET](#).

---

**W**

**WAN** Wide-area network. A data communications network that serves users across a broad geographic area and often uses transmission devices provided by a common carrier (such as a telephone company or service provider).

**Weighted Fair Queuing** See [WFQ](#).

**Weighted Random Early Detection** See [WRED](#).

**WFQ** Weighted Fair Queuing. Congestion management algorithm that identifies conversations (in the form of traffic streams), separates packets that belong to each conversation, and ensures that capacity is shared fairly between these individual conversations. WFQ is an automatic way of stabilizing network behavior during congestion and results in better performance and fewer retransmissions.

**Wide-area network** See [WAN](#).

**WRED** Weighted Random Early Detection. RED uses an algorithm to randomly discard packets. The result of the drop is that the source detects the dropped traffic and slows its transmission. WRED combines the capabilities of the RED algorithm with IP precedence. This combination provides for preferential traffic handling for higher-priority packets. It can selectively discard lower-priority traffic when the interface starts to get congested and provide differentiated performance characteristics for different classes of service.





## INDEX

---

### Numerics

19-inch rack [3-3](#)

---

### A

AC/DC power [1-3](#)

AC PEM

description [1-7](#)

air filter, replacing [5-7](#)

airflow [A-1](#)

cautions [3-2](#)

chassis clearance [2-9, 2-10](#)

alarm block terminals

common [5-35](#)

normally closed [5-35](#)

normally open [5-35](#)

alarm indicators

connecting [5-32](#)

Critical [5-32](#)

Major [5-32](#)

Minor [5-32](#)

alphanumeric display on PRE [1-11](#)

altitude [2-2](#)

altitude, specifications [A-1](#)

application specific integrated circuits (ASICs) [1-8](#)

automatic protection switching (APS) [1-1](#)

---

### B

Bellcore GR-63 [A-1](#)

BGP peers [1-2](#)

blower module

description [1-6](#)

replacing [5-10](#)

troubleshooting [5-11](#)

BNC connectors [1-3](#)

boot

command [4-11](#)

configuration file [4-9](#)

bootflash, secondary [4-7](#)

boot loader [1-3](#)

boot status messages [1-11](#)

brackets, selecting [3-1](#)

Break function [4-9](#)

BTUs, maximum [2-2](#)

buffer

size, changing [4-9](#)

---

### C

cable length, factors determining [2-5](#)

cable-management kit [3-1](#)

using [3-2](#)

cables

crossover [3-30](#)

straight-through Ethernet [3-33](#)

chassis

air circulation [3-2](#)

center-mounting (19 in. rack) [3-5](#)

center-mounting (23 in. rack) [3-7](#)

components [1-6](#)

connecting to ground [3-13](#)

flush-mounting (19 in. rack) [3-3](#)

front view [1-4](#)

ground connection description [2-4](#)

- grounding lugs [3-14](#)
  - line card slots [1-1](#)
  - module compartment [1-8](#)
  - non-rack installation [3-11](#)
  - preventing overheating [2-9, 3-2](#)
  - rack-mounting procedures [3-2](#)
  - rear view [1-3](#)
  - circuit requirements [2-3](#)
  - circuitry [viii](#)
  - Cisco 10000 Series edge services router (ESR)
    - powerup [4-11](#)
  - Cisco 10008 router
    - basic setup [4-4](#)
    - Ethernet port [4-5](#)
    - features [1-2](#)
    - hardware description [1-3](#)
    - setup facility [4-3](#)
    - software description [1-3](#)
  - CLI
    - file system names [4-7](#)
  - CLI, setup facility [4-2](#)
  - coaxial cable [2-5](#)
  - command prompt [4-6](#)
  - commands
    - boot [4-11](#)
    - config register value [4-10](#)
    - copy [4-8, 5-3](#)
    - copy startup config running config [4-8](#)
    - del [4-8](#)
    - dir [4-8](#)
    - no shutdown [4-5](#)
    - privileged EXEC [4-8](#)
    - reload [4-10](#)
    - service compress-config global configuration [4-8](#)
    - setup [4-6](#)
    - show environment [2-9](#)
    - show facility-alarm status [4-12](#)
    - show version [4-10](#)
  - compliance information [xi](#)
  - config register value command [4-10](#)
  - configuration setup [4-4](#)
  - connectors
    - 20A [3-22](#)
    - AC power cord [3-26](#)
    - DB-25 serial [3-31](#)
    - DB-9 serial [3-31](#)
    - DS3 [3-32](#)
    - RJ-45 [4-5](#)
  - console port [4-2](#)
    - problems [4-14](#)
  - copper conductors [2-4](#)
  - copy command [4-8, 5-3](#)
  - copy startup-config running-config command [4-8](#)
  - CT3 line card
    - See channelized T3 line card
- 
- ## D
- DB-25 serial connector [3-31](#)
  - DB-9 serial connector [3-31](#)
  - DC PEM
    - description [1-6](#)
    - power connectors [3-17](#)
  - default
    - filename [4-11](#)
  - DIMMs
    - handling [5-49](#)
    - replacing [5-47](#)
    - troubleshooting [5-49](#)
  - display on PRE [1-11](#)
- 
- ## E
- electrical wiring requirements [2-3](#)
  - electromagnetic interference shielding [2-12](#)
  - electromagnetic pulse
    - See EMP



EMI

- predict and remedy [2-6](#)
- shielding [2-12](#)

EMP, avoiding [2-6](#)

ESD

- prevention guidelines [2-12](#)
- wrist strap [2-12](#)

Ethernet

- 10BASE-T [3-32](#)
- cable [3-33](#)
- cable requirements [3-32](#)
- connection to 10BASE-T [3-32](#)
- hub [3-33](#)
- LAN connections [3-33](#)
- straight-through cable [3-33](#)

Ethernet port [4-5](#)

---

**F**

Fast Ethernet

- 100BASE-T connection [3-33](#)
- cable requirements [3-33](#)

fast Ethernet port [4-11](#)

field replaceable unit

- See FRU

files

- compressing [4-8](#)
- managing [4-8](#)
- storing remotely [4-7](#)

file systems, managing [4-7](#)

filter, replacing [5-1](#)

Flash cards and disks, formatting [4-6](#)

Flash disk, storing files [4-9](#)

Flash memory

- ATA disk [4-7](#)
- cards [4-7](#)
- single inline memory module [4-11](#)

Frame Relay sessions [1-2](#)

front cover

- removing [5-4](#)
- replacing [5-6](#)

front view of chassis [1-4](#)

FRU

- removing and replacing [5-3](#)
- troubleshooting [4-12](#)

FTP protocol [4-7](#)

---

## G

grounding lug

- Burndy # YA8CL2TC10 [3-14](#)
- Panduit # LCD8-10-AL [3-14](#)
- Thomas & Betts # 54204 [3-14](#)

---

## H

half-height line card subslot designations [1-3](#)

hex values [4-11](#)

high-speed trunk interface [1-1](#)

hot-swapping [1-1](#)

humidity [2-2](#)

- specifications [A-1](#)

---

## I

installing [5-44](#)

- AC PEM [5-24](#)
- air filter [5-7](#)
- blower module [5-10](#)
- DC PEM [5-12](#)
- DIMMs [5-47](#)
- front cover [5-6](#)
- general guidelines [3-2](#)
- lifting chassis [2-15](#)
- PRE [5-36](#)

interface cable [3-1](#)

interference

radio frequency [2-6](#)

IOS command line interface

See CLI

IP

address [4-14](#)

router address [4-2](#)

routing command [4-6](#)

subnet mask [4-5](#)

ISP, requirements [1-1](#)

---

## L

Layer 3 router [1-1](#)

LEDs

fan failure [4-13](#)

fault [4-12](#)

LNK [4-13](#)

major, minor, critical [4-12](#)

miswire [4-12](#)

power [4-12](#)

line cards

channelized T3 [1-2](#)

failure [1-2](#)

hot swapping [5-1](#)

initialization [4-2](#)

making connections [3-32](#)

shutting down [5-1](#)

lithium battery on PRE [1-11](#)

loss of service [5-3](#)

low-speed circuits [1-1](#)

---

## M

modem connections [3-35](#)

---

## N

no shutdown command [4-5](#)

NVRAM

file system [4-7](#)

ignoring contents [4-9](#)

size [4-8](#)

---

## O

operating conditions, chassis [2-5](#)

optical network interfaces [1-1](#)

---

## P

Parallel eXpress Forwarding [1-8](#)

password

secret [4-4](#)

Telnet [4-4](#)

PCMCIA

backing up [5-3](#)

card slots [1-10](#)

flash cards [1-10, 5-44](#)

PCMCIA flash cards [5-44](#)

PEM

AC

description [1-7](#)

installing second [5-24](#)

replacing [5-28](#)

specifications [A-2](#)

DC [5-20](#)

description [1-6](#)

installing second [5-12](#)

power leads [5-17](#)

replacing [5-20](#)

specifications [A-2](#)

performance routing engine

See PRE

pinouts [4-14](#)

ports

CON [A-3](#)

- Ethernet [4-13](#)
- PRE auxiliary [1-9, A-3](#)
- PRE console [1-9](#)
- PRE Ethernet [1-9, A-3](#)
- RJ-45 [3-34](#)
- power
  - AC/DC [1-3](#)
  - surge suppression [2-6](#)
- power cord [3-22](#)
- powerup [4-11](#)
- PPP sessions [1-2](#)
- PRE
  - alphanumeric display [1-11](#)
  - auxiliary port [1-9](#)
  - console port [1-9](#)
  - description [1-8](#)
  - disposing [1-11](#)
  - Ethernet port [1-9](#)
  - front panel [1-9](#)
  - hot-swapping [1-9](#)
  - PCMCIA card slots [1-10](#)
  - replacing [5-36](#)
  - replacing DIMMs [5-47](#)
  - specifications [A-3](#)
- product disposal [1-11](#)
- protocols
  - FTP [4-7](#)
  - RCP [4-7](#)
  - TFTP [4-7](#)
- PXF [1-8](#)

---

## R

- rack-mounting the unit [3-1](#)
- RCP protocol [4-7](#)
- rear view of chassis [1-3](#)
- redundancy [1-2, 5-2](#)
- regulatory information [xi](#)
- reload command [4-10](#)

- remote devices [4-5](#)
- RJ-45 connectors [2-6](#)
- rommon boot command [4-11](#)
- ROM monitor/boot loader [1-3](#)
- router [viii](#)
  - rebooting [4-10](#)
- RS-232 asynchronous data [2-6](#)

---

## S

- safety
  - warning definition [x](#)
- safety guidelines
  - electricity [2-13](#)
  - preventing electrostatic discharge damage [2-12](#)
- safety information [xi](#)
- scalability [1-2](#)
- SDRAM
  - configurations [5-46](#)
  - upgrading [5-46](#)
- secondary bootflash [4-7](#)
- service compress-config global configuration command [4-8](#)
- setup command [4-6](#)
- show environment command [2-9](#)
- show facility-alarm status command [4-12](#)
- show int fast0/0/0 command [4-14](#)
- show version command [4-10](#)
- SIMM [4-11](#)
- single inline memory module [4-11](#)
- SONET
  - 1+1 automatic protection switching [1-1](#)
- spare parts [5-2](#)
- squeeze command [4-8](#)
- status messages [1-11](#)
- subnet mask [4-5](#)
- subslot designations for half-height line cards [1-3](#)
- system configuration dialog [4-4](#)
- system shutdown [5-3](#)

---

**T**

T1 connections [1-2](#)

telco

environment [1-1](#)

rack [3-1](#)

Telnet

connection [4-13](#)

session [4-4](#)

temperature [2-2](#)

warning messages [2-9](#)

terminal server connections [4-2](#)

TFTP

protocol [4-7](#)

server [4-11](#)

tie wraps [5-18, 5-36](#)

tools and supplies [3-18](#)

tools for maintenance [5-3](#)

twisted-pair cabling [2-6](#)

work during lightening activity [2-14](#)

warning, description [x](#)

wiring

practices [viii](#)

safety (warning) [2-4](#)

---

**U**

undelete command [4-8](#)

---

**V**

voltage [2-2](#)

---

**W**

warning [1-11](#)

chassis installation [3-3, 3-5, 3-7](#)

disconnect device [2-5](#)

installation instructions [2-14](#)

jewelry removal [2-14, 3-17](#)

qualified personnel [2-12](#)

short-circuit protection [3-18](#)

two-person lifting [2-15, 3-12](#)