



Cisco 7206 Installation and Configuration Guide

Corporate Headquarters
Cisco Systems, Inc.
170 West Tasman Drive
San Jose, CA 95134-1706
USA
<http://www.cisco.com>
Tel: 408 526-4000
800 553-NETS (6387)
Fax: 408 526-4100

Customer Order Number:
Text Part Number: OL-5102-02



THE SPECIFICATIONS AND INFORMATION REGARDING THE PRODUCTS IN THIS MANUAL ARE SUBJECT TO CHANGE WITHOUT NOTICE. ALL STATEMENTS, INFORMATION, AND RECOMMENDATIONS IN THIS MANUAL ARE BELIEVED TO BE ACCURATE BUT ARE PRESENTED WITHOUT WARRANTY OF ANY KIND, EXPRESS OR IMPLIED. USERS MUST TAKE FULL RESPONSIBILITY FOR THEIR APPLICATION OF ANY PRODUCTS.

THE SOFTWARE LICENSE AND LIMITED WARRANTY FOR THE ACCOMPANYING PRODUCT ARE SET FORTH IN THE INFORMATION PACKET THAT SHIPPED WITH THE PRODUCT AND ARE INCORPORATED HEREIN BY THIS REFERENCE. IF YOU ARE UNABLE TO LOCATE THE SOFTWARE LICENSE OR LIMITED WARRANTY, CONTACT YOUR CISCO REPRESENTATIVE FOR A COPY.

The following information is for FCC compliance of Class A devices: This equipment has been tested and found to comply with the limits for a Class A digital device, pursuant to part 15 of the FCC rules. These limits are designed to provide reasonable protection against harmful interference when the equipment is operated in a commercial environment. This equipment generates, uses, and can radiate radio-frequency energy and, if not installed and used in accordance with the instruction manual, may cause harmful interference to radio communications. Operation of this equipment in a residential area is likely to cause harmful interference, in which case users will be required to correct the interference at their own expense.

The following information is for FCC compliance of Class B devices: The equipment described in this manual generates and may radiate radio-frequency energy. If it is not installed in accordance with Cisco's installation instructions, it may cause interference with radio and television reception. This equipment has been tested and found to comply with the limits for a Class B digital device in accordance with the specifications in part 15 of the FCC rules. These specifications are designed to provide reasonable protection against such interference in a residential installation. However, there is no guarantee that interference will not occur in a particular installation.

Modifying the equipment without Cisco's written authorization may result in the equipment no longer complying with FCC requirements for Class A or Class B digital devices. In that event, your right to use the equipment may be limited by FCC regulations, and you may be required to correct any interference to radio or television communications at your own expense.

You can determine whether your equipment is causing interference by turning it off. If the interference stops, it was probably caused by the Cisco equipment or one of its peripheral devices. If the equipment causes interference to radio or television reception, try to correct the interference by using one or more of the following measures:

- Turn the television or radio antenna until the interference stops.
- Move the equipment to one side or the other of the television or radio.
- Move the equipment farther away from the television or radio.
- Plug the equipment into an outlet that is on a different circuit from the television or radio. (That is, make certain the equipment and the television or radio are on circuits controlled by different circuit breakers or fuses.)

Modifications to this product not authorized by Cisco Systems, Inc. could void the FCC approval and negate your authority to operate the product.

The Cisco implementation of TCP header compression is an adaptation of a program developed by the University of California, Berkeley (UCB) as part of UCB's public domain version of the UNIX operating system. All rights reserved. Copyright © 1981, Regents of the University of California.

NOTWITHSTANDING ANY OTHER WARRANTY HEREIN, ALL DOCUMENT FILES AND SOFTWARE OF THESE SUPPLIERS ARE PROVIDED "AS IS" WITH ALL FAULTS. CISCO AND THE ABOVE-NAMED SUPPLIERS DISCLAIM ALL WARRANTIES, EXPRESSED OR IMPLIED, INCLUDING, WITHOUT LIMITATION, THOSE OF MERCHANTABILITY, FITNESS FOR A PARTICULAR PURPOSE AND NONINFRINGEMENT OR ARISING FROM A COURSE OF DEALING, USAGE, OR TRADE PRACTICE.

IN NO EVENT SHALL CISCO OR ITS SUPPLIERS BE LIABLE FOR ANY INDIRECT, SPECIAL, CONSEQUENTIAL, OR INCIDENTAL DAMAGES, INCLUDING, WITHOUT LIMITATION, LOST PROFITS OR LOSS OR DAMAGE TO DATA ARISING OUT OF THE USE OR INABILITY TO USE THIS MANUAL, EVEN IF CISCO OR ITS SUPPLIERS HAVE BEEN ADVISED OF THE POSSIBILITY OF SUCH DAMAGES.

CCIP, CCSP, the Cisco Arrow logo, the Cisco *Powered* Network mark, Cisco Unity, Follow Me Browsing, FormShare, and StackWise are trademarks of Cisco Systems, Inc.; Changing the Way We Work, Live, Play, and Learn, and iQuick Study are service marks of Cisco Systems, Inc.; and Aironet, ASIST, BPX, Catalyst, CCDA, CCDP, CCIE, CCNA, CCNP, Cisco, the Cisco Certified Internetwork Expert logo, Cisco IOS, the Cisco IOS logo, Cisco Press, Cisco Systems, Cisco Systems Capital, the Cisco Systems logo, Empowering the Internet Generation, Enterprise/Solver, EtherChannel, EtherFast, EtherSwitch, Fast Step, GigaDrive, GigaStack, HomeLink, Internet Quotient, IOS, IP/TV, iQ Expertise, the iQ logo, iQ Net Readiness Scorecard, LightStream, Linksys, MeetingPlace, MGX, the Networkers logo, Networking Academy, Network Registrar, *Packet*, PIX, Post-Routing, Pre-Routing, ProConnect, RateMUX, Registrar, ScriptShare, SlideCast, SMARTnet, StrataView Plus, SwitchProbe, TeleRouter, The Fastest Way to Increase Your Internet Quotient, TransPath, and VCO are registered trademarks of Cisco Systems, Inc. and/or its affiliates in the United States and certain other countries.

All other trademarks mentioned in this document or Website are the property of their respective owners. The use of the word partner does not imply a partnership relationship between Cisco and any other company. (0403R)



Preface vii

Audience	vii
Organization	viii
Document Conventions	ix
Warning Definition	x
Terms and Acronyms	xiii
Related Documentation	xiv
Obtaining Documentation	xiv
Cisco.com	xiv
Ordering Documentation	xv
Documentation Feedback	xv
Obtaining Technical Assistance	xv
Cisco Technical Support Website	xvi
Submitting a Service Request	xvi
Definitions of Service Request Severity	xvi
Obtaining Additional Publications and Information	xvii

CHAPTER 1

Product Overview 1-1

Physical Description	1-2
System Specifications	1-5
Software Requirements	1-6
Field-Replaceable Units	1-7
Network Processing Engine	1-7
Input/Output Controller	1-14
LED Descriptions	1-18
Port Adapters and Service Adapters	1-24
Power Supplies	1-24
Chassis	1-26
Flash Disks and Flash Memory Cards	1-27
Rack-Mount and Cable-Management Kit	1-28
Functional Overview	1-28
Port Adapter Slot and Logical Interface Numbering	1-28
MAC Address	1-30

- Online Insertion and Removal 1-30
- Environmental Monitoring and Reporting Functions 1-31
 - Environmental Monitoring 1-31
 - Reporting Functions 1-33
 - Fan Failures 1-35

CHAPTER 2

- Preparing for Installation 2-1**
 - Electrical Equipment Guidelines 2-1
 - Preventing Electrostatic Discharge Damage 2-2
 - Site Requirements 2-2
 - AC and DC Power 2-2
 - Plant Wiring Guidelines 2-2
 - Interference Considerations 2-2
 - Distance Limitations and Interface Specifications 2-3
 - Equipment Racks 2-4
 - Site Environment 2-6
 - Preventive Site Configuration: Maintaining Normal Operation 2-6
 - General Precautions 2-8
 - Power Considerations 2-8
 - Tools for Installation 2-8
 - Initial Configuration Information 2-9
 - Cisco 7206 Installation Checklist 2-10
 - Checking the Shipping Container Contents 2-11
 - Site Log 2-12

CHAPTER 3

- Installing the Cisco 7206 3-1**
 - Rack-Mounting the Cisco 7206 3-2
 - Attaching the Chassis Rack-Mount and Cable-Management Brackets 3-5
 - Installing the Brackets on the Front of the Chassis 3-6
 - Installing Brackets on the Rear of the Chassis 3-7
 - Installing the Chassis in the Rack 3-9
 - General Tabletop or Workbench Installation 3-9
 - Installing the Cable-Management Brackets 3-10
 - Securing the Port Adapter Cables 3-11
 - Providing a Chassis Ground Connection for the Router Chassis 3-12
 - Connecting Port Adapter Cables 3-14
 - Connecting I/O Controller Cables 3-14
 - Console and Auxiliary Port Connection Equipment 3-14

Console Port Signals	3-15
Auxiliary Port Signals	3-16
Fast Ethernet Connection Equipment	3-16
Fast Ethernet MII Connection Equipment	3-17
Ethernet and Fast Ethernet RJ-45 Connection Equipment	3-18
Connecting Power	3-20
Connecting AC-Input Power	3-20
Connecting DC-Input Power	3-21
Starting the Cisco 7206	3-24

CHAPTER 4

Performing a Basic Configuration of the Cisco 7206	4-1
Using the Enable Secret and the Enable Password	4-1
Configuring the Cisco 7206	4-2
Configuring the Cisco 7206 Using AutoInstall	4-2
Configuring the Cisco 7206 Manually Using the Setup Facility	4-3
Configuring Global Parameters	4-3
Configuring Interfaces	4-6
Configuring the Cisco 7206 Using Configuration Mode	4-9
Saving Your Settings to NVRAM	4-10
Checking Your Settings and Reviewing Your Configuration Changes	4-10
Performing Other Configuration Tasks	4-10
Performing a Complex Configuration	4-11

CHAPTER 5

Maintaining the Cisco 7206	5-1
Viewing Your System Configuration	5-1
Replacing a Port Adapter or Service Adapter	5-4
Removing a Port or Service Adapter	5-4
Installing a Port Adapter or Service Adapter	5-5
Installing and Removing a Flash Memory Card	5-7
Inserting a Flash Memory Card	5-7
Removing a Flash Memory Card	5-9
Formatting a New Flash Memory Card	5-9
Copying a Bootable Image onto a Flash Memory Card	5-10
Copying Bootable Images between Flash Memory Cards	5-11
Reformatting a Flash Memory Card	5-12
Replacing or Recovering a Lost Password	5-14
Overview of the Password Recovery Procedure	5-14
Details of the Password Recovery Procedure	5-15

CHAPTER 6

Troubleshooting the Installation 6-1

- Contacting a Customer Service Representative 6-1
- Troubleshooting Overview 6-2
 - Using a Subsystems Approach to Problem Solving 6-3
 - Identifying Startup Problems 6-3
- Troubleshooting the Power Subsystem 6-5
- Troubleshooting the Processor Subsystem 6-6
 - Troubleshooting the I/O Controller 6-6
 - Troubleshooting the Network Processing Engine 6-7
 - Troubleshooting the Port Adapter and Service Adapters 6-7
- Troubleshooting the Cooling Subsystem 6-7

APPENDIX A

Industry-Standard Wiring Plans 1

APPENDIX B

Configuration Register Information B-1

- Configuration Bit Meanings B-1
 - Bits 0–3 B-2
 - Bit 6 B-3
 - Bit 7 B-3
 - Bit 8 B-4
 - Bit 10 and Bit 14 B-4
 - Bit 11 and Bit 12 B-4
 - Bit 13 B-4
 - Bit 15 B-5
- Displaying the Configuration Register While Running Cisco IOS B-5
- Displaying the Configuration Register While Running ROM Monitor B-5
- Setting the Configuration Register While Running Cisco IOS B-6
- Setting the Configuration Register While Running ROM Monitor B-6

INDEX



Preface

This preface explains the objectives, intended audience, and organization of the *Cisco 7206 Installation and Configuration Guide*, and defines the conventions used to convey instructions and information.



Note

The Cisco 7206 is also available as a router shelf in a Cisco AS5800 Universal Access Server. If your Cisco 7206 is installed as a router shelf in a Cisco AS5800 Universal Access Server, use this configuration note in conjunction with the *Cisco AS5800 Universal Access Server Hardware Installation and Configuration Guide* and the *Cisco AS5800 Universal Access Server Software Installation and Configuration Guide* that shipped with your Cisco AS5800 Universal Access Server.

Audience

To use this publication, you should be familiar with Cisco router hardware and cabling, electronic circuitry and wiring practices, and preferably have experience as an electronic or electromechanical technician.

Organization

The major sections of this guide are as follows:

Chapter	Title	Description
Chapter 1	Product Overview	This chapter describes the physical properties of the Cisco 7206 and provides a functional overview of the router.
Chapter 2	Preparing for Installation	This chapter is a preparatory section that describes safety considerations, tools required, an overview of the installation, and procedures you should perform <i>before</i> the actual installation.
Chapter 3	Installing the Cisco 7206	This chapter provides instructions for installing the hardware and connecting the external network interface cables.
Chapter 4	Performing a Basic Configuration of the Cisco 7206	This chapter provides simple procedures for completing a basic system configuration and for checking and saving this configuration to system memory.
Chapter 5	Maintaining the Cisco 7206	This chapter provides simple maintenance procedures that you might need to perform after you have installed your Cisco 7206.
Chapter 6	Troubleshooting the Installation	This chapter provides guidelines for troubleshooting the hardware installation.
Appendix A	Industry-Standard Wiring Plans	This appendix lists the telephone industry color-code scheme for 25-pair wires including the pin numbers.
Appendix B	Configuration Register Information	This appendix provides configuration register information.

(DRAFT LABEL) ALPHA DRAFT - CISCO CONFIDENTIAL

Document Conventions

This publication uses the following conventions:

Examples that contain system prompts denote interactive sessions, indicating the commands that you should enter at the prompt. The system prompt indicates the current level of the EXEC command interpreter. For example, the prompt `router>` indicates that you should be at the *user* level, and the prompt `router#` indicates that you should be at the *privileged* level. Access to the privileged level usually requires a password. Refer to the related software configuration and reference documentation listed in the “[Related Documentation](#)” section on page [xiv](#) for additional information.

Other command descriptions use the following conventions:

boldface font	Commands and keywords are in boldface.
<i>italic font</i>	Arguments for which you supply values are in <i>italic</i> font.
[]	Elements in square brackets ([]) are optional.
{ x y z }	Alternative but required keywords are grouped in braces ({ }) and separated by vertical bars ().

Screen examples use the following conventions:

screen font	Terminal sessions and sample console screen displays are in screen font.
boldface screen font	Information you enter is in boldface screen font.
< >	Nonprinting characters, such as passwords, are in angle brackets (< >).
[]	Default responses to system prompts are in square brackets ([]).
^	The symbol ^ represents the key labeled Control . For example, the key combination ^z means hold down the Control key while you press the z key.
(!)	Exclamation points (!) at the beginning of a line indicate a comment line.



Caution

Means *reader be careful*. You are capable of doing something that might result in equipment damage or loss of data.



Note

Means *reader take note*. Notes contain helpful suggestions or references to materials not contained in this manual.

Warning Definition



Warning

IMPORTANT SAFETY INSTRUCTIONS

This warning symbol means danger. You are in a situation that could cause bodily injury. Before you work on any equipment, be aware of the hazards involved with electrical circuitry and be familiar with standard practices for preventing accidents. To see translations of the warnings that appear in this publication, refer to the translated safety warnings that accompanied this device.

Note: SAVE THESE INSTRUCTIONS

Note: This documentation is to be used in conjunction with the specific product installation guide that shipped with the product. Please refer to the Installation Guide, Configuration Guide, or other enclosed additional documentation for further details.

Waarschuwing

BELANGRIJKE VEILIGHEIDSINSTRUCTIES

Dit waarschuwingssymbool betekent gevaar. U verkeert in een situatie die lichamelijk letsel kan veroorzaken. Voordat u aan enige apparatuur gaat werken, dient u zich bewust te zijn van de bij elektrische schakelingen betrokken risico's en dient u op de hoogte te zijn van de standaard praktijken om ongelukken te voorkomen. Voor een vertaling van de waarschuwingen die in deze publicatie verschijnen, dient u de vertaalde veiligheidswaarschuwingen te raadplegen die bij dit apparaat worden geleverd.

Opmerking BEWAAR DEZE INSTRUCTIES.

Opmerking Deze documentatie dient gebruikt te worden in combinatie met de installatiehandleiding voor het specifieke product die bij het product wordt geleverd. Raadpleeg de installatiehandleiding, configuratiehandleiding of andere verdere ingesloten documentatie voor meer informatie.

Varoitus

TÄRKEITÄ TURVALLISUUTEEN LIITTYVIÄ OHJEITA

Tämä varoitusmerkki merkitsee vaaraa. Olet tilanteessa, joka voi johtaa ruumiinvammaan. Ennen kuin työskentelet minkään laitteiston parissa, ota selvää sähkökytkentöihin liittyvistä vaaroista ja tavanomaisista onnettomuuksien ehkäisykeinoista. Tässä asiakirjassa esitettyjen varoitusten käännökset löydät laitteen mukana toimitetuista ohjeista.

Huomautus SÄILYTÄ NÄMÄ OHJEET

Huomautus Tämä asiakirja on tarkoitettu käytettäväksi yhdessä tuotteen mukana tulleen asennusoppaan kanssa. Katso lisätietoja asennusoppaasta, kokoonpano-oppaasta ja muista mukana toimitetuista asiakirjoista.

(DRAFT LABEL) ALPHA DRAFT - CISCO CONFIDENTIAL**Attention IMPORTANTES INFORMATIONS DE SÉCURITÉ**

Ce symbole d'avertissement indique un danger. Vous vous trouvez dans une situation pouvant causer des blessures ou des dommages corporels. Avant de travailler sur un équipement, soyez conscient des dangers posés par les circuits électriques et familiarisez-vous avec les procédures couramment utilisées pour éviter les accidents. Pour prendre connaissance des traductions d'avertissements figurant dans cette publication, consultez les consignes de sécurité traduites qui accompagnent cet appareil.

Remarque CONSERVEZ CES INFORMATIONS

Remarque Cette documentation doit être utilisée avec le guide spécifique d'installation du produit qui accompagne ce dernier. Veuillez vous reporter au Guide d'installation, au Guide de configuration, ou à toute autre documentation jointe pour de plus amples renseignements.

Warnung WICHTIGE SICHERHEITSANWEISUNGEN

Dieses Warnsymbol bedeutet Gefahr. Sie befinden sich in einer Situation, die zu einer Körperverletzung führen könnte. Bevor Sie mit der Arbeit an irgendeinem Gerät beginnen, seien Sie sich der mit elektrischen Stromkreisen verbundenen Gefahren und der Standardpraktiken zur Vermeidung von Unfällen bewusst. Übersetzungen der in dieser Veröffentlichung enthaltenen Warnhinweise sind im Lieferumfang des Geräts enthalten.

Hinweis BEWAHREN SIE DIESE SICHERHEITSANWEISUNGEN AUF

Hinweis Dieses Handbuch ist zum Gebrauch in Verbindung mit dem Installationshandbuch für Ihr Gerät bestimmt, das dem Gerät beiliegt. Entnehmen Sie bitte alle weiteren Informationen dem Handbuch (Installations- oder Konfigurationshandbuch o. Ä.) für Ihr spezifisches Gerät.

Figyelem FONTOS BIZTONSÁGI ELOÍRÁSOK

Ez a figyelmeztető jel veszélyre utal. Sérülésveszélyt rejtő helyzetben van. Mielőtt bármely berendezésen munkát végezte, legyen figyelemmel az elektromos áramkörök okozta kockázatokra, és ismerkedjen meg a szokásos balesetvédelmi eljárásokkal. A kiadványban szereplő figyelmeztetések fordítása a készülékhez mellékelte biztonsági figyelmeztetések között található; a fordítás az egyes figyelmeztetések végén látható szám alapján kereshető meg.

ORIZZE MEG EZEKET AZ UTASÍTÁSOKAT!**Avvertenza IMPORTANTI ISTRUZIONI SULLA SICUREZZA**

Questo simbolo di avvertenza indica un pericolo. La situazione potrebbe causare infortuni alle persone. Prima di intervenire su qualsiasi apparecchiatura, occorre essere al corrente dei pericoli relativi ai circuiti elettrici e conoscere le procedure standard per la prevenzione di incidenti. Per le traduzioni delle avvertenze riportate in questo documento, vedere le avvertenze di sicurezza che accompagnano questo dispositivo.

Nota CONSERVARE QUESTE ISTRUZIONI

Nota La presente documentazione va usata congiuntamente alla guida di installazione specifica spedita con il prodotto. Per maggiori informazioni, consultare la Guida all'installazione, la Guida alla configurazione o altra documentazione acclusa.

Advarsel VIKTIGE SIKKERHETSINSTRUKSJONER

Dette varselssymbolet betyr fare. Du befinner deg i en situasjon som kan forårsake personskade. Før du utfører arbeid med utstyret, bør du være oppmerksom på farene som er forbundet med elektriske kretssystemer, og du bør være kjent med vanlig praksis for å unngå ulykker. For å se oversettelser av advarslene i denne publikasjonen, se de oversatte sikkerhetsvarslene som følger med denne enheten.

Merk TA VARE PÅ DISSE INSTRUKSJONENE

Merk Denne dokumentasjonen skal brukes i forbindelse med den spesifikke installasjonsveiledningen som fulgte med produktet. Vennligst se installasjonsveiledningen, konfigureringsveiledningen eller annen vedlagt tilleggsdokumentasjon for detaljer.

Aviso INSTRUÇÕES IMPORTANTES DE SEGURANÇA

Este símbolo de aviso significa perigo. O utilizador encontra-se numa situação que poderá ser causadora de lesões corporais. Antes de iniciar a utilização de qualquer equipamento, tenha em atenção os perigos envolvidos no manuseamento de circuitos eléctricos e familiarize-se com as práticas habituais de prevenção de acidentes. Para ver traduções dos avisos incluídos nesta publicação, consulte os avisos de segurança traduzidos que acompanham este dispositivo.

Nota GUARDE ESTAS INSTRUÇÕES

Nota Esta documentação destina-se a ser utilizada em conjunto com o manual de instalação incluído com o produto específico. Consulte o manual de instalação, o manual de configuração ou outra documentação adicional inclusa, para obter mais informações.

¡Advertencia! INSTRUCCIONES IMPORTANTES DE SEGURIDAD

Este símbolo de aviso indica peligro. Existe riesgo para su integridad física. Antes de manipular cualquier equipo, considere los riesgos de la corriente eléctrica y familiarícese con los procedimientos estándar de prevención de accidentes. Vea las traducciones de las advertencias que acompañan a este dispositivo.

Nota GUARDE ESTAS INSTRUCCIONES

Nota Esta documentación está pensada para ser utilizada con la guía de instalación del producto que lo acompaña. Si necesita más detalles, consulte la Guía de instalación, la Guía de configuración o cualquier documentación adicional adjunta.

Varning! VIKTIGA SÄKERHETSANVISNINGAR

Denna varningssignal signalerar fara. Du befinner dig i en situation som kan leda till personskada. Innan du utför arbete på någon utrustning måste du vara medveten om farorna med elkretsar och känna till vanliga förfaranden för att förebygga olyckor. Se översättningarna av de varningsmeddelanden som finns i denna publikation, och se de översatta säkerhetsvarningarna som medföljer denna anordning.

OBS! SPARA DESSA ANVISNINGAR

OBS! Denna dokumentation ska användas i samband med den specifika produktinstallationshandbok som medföljde produkten. Se installationshandboken, konfigurationshandboken eller annan bifogad ytterligare dokumentation för närmare detaljer.

*(DRAFT LABEL) ALPHA DRAFT - CISCO CONFIDENTIAL***Предупреждение** **ВАЖНЫЕ СВЕДЕНИЯ ПО БЕЗОПАСНОСТИ**

Этот символ предупреждает о наличии опасности. При неправильных действиях возможно получение травм. Перед началом работы с любым оборудованием необходимо ознакомиться с ситуациями, в которых возможно поражение электротоком, и со стандартными действиями для предотвращения несчастных случаев. Переведенный текст предупреждений содержится в соответствующем документе, поставляемом вместе с устройством.

Примечание **СОХРАНЯЙТЕ ЭТУ ИНСТРУКЦИЮ**

Примечание Эта инструкция должна использоваться вместе с руководством по установке конкретного изделия, входящим в комплект поставки. Дополнительные сведения см. в руководстве по установке, руководстве по настройке и другой документации, поставляемой с изделием.

警告 **有关安全的重要说明**

这个警告符号指有危险。您所处的环境可能使身体受伤。操作设备前必须意识到电流的危险性，务必熟悉操作标准，以防发生事故。如果需要了解本说明中出现的警告符号的译文，请参阅本装置所附之安全警告译文。

注意 保存这些说明

注意 本文件应与本产品附带的特定安装说明一并阅读。如欲了解详情，请参阅《安装说明》、《配置说明》或所附的其他文件。

警告 **安全上の重要な注意事項**

「危険」の意味です。人身事故を予防するための注意事項が記述されています。装置の取り扱い作業を行うときは、電気回路の危険性に注意し、一般的な事故防止対策に留意してください。このマニュアルに記載されている警告の各国語版は、装置に付属の「Translated Safety Warnings」を参照してください。

注 これらの注意事項を保管しておいてください。

注 この資料は、製品に付属のインストレーション ガイドと併用してください。詳細は、インストレーション ガイド、コンフィギュレーション ガイド、または添付されているその他のマニュアルを参照してください。

Terms and Acronyms

To fully understand the content of this user guide, you should be familiar with the following terms and acronyms:

- DMA—Direct memory access
- DRAM—Dynamic random-access memory
- DCE—Data communications equipment
- DTE—Data terminal equipment
- EPROM—Erasable programmable read-only memory
- FRU—Field-replaceable unit (router components that do not require replacement by a Cisco-certified service provider)

- Gbps—Gigabits per second
- MB—Megabyte
- NVRAM—Nonvolatile random-access memory
- OIR—Online insertion and removal
- PCI—Peripheral component interconnect
- PCMCIA—Personal Computer Memory Card International Association
- RFI—Radio frequency interference
- RISC—Reduced instruction set computing
- SIMM—Single in-line memory module
- SNMP—Simple Network Management Protocol
- SRAM—Static random-access memory
- TFTP—Trivial File Transfer Protocol

Related Documentation

Your Cisco 7206 router and the Cisco IOS software running on it contain extensive features and functionality, which are documented in the following resources:

- *Cisco 7200 Series Routers Documentation Roadmap* at <http://www.cisco.com/univercd/cc/td/doc/product/core/7200vx/ol3512.htm> for a list of all Cisco 7200 series routers documentation and troubleshooting tools and information.
- *Cisco 7200 Series Routers Port Adapter Documentation Roadmap* at <http://www.cisco.com/univercd/cc/td/doc/product/core/7200vx/ol3530.htm> for a list of all Cisco 7200 series routers-supported port adapter documentation.
- *Cisco 7200 Series Routers Troubleshooting Documentation Roadmap* at <http://www.cisco.com/univercd/cc/td/doc/product/core/7200vx/ol3518.htm> for links to troubleshooting tools, utilities, and Tech Notes.

Obtaining Documentation

Cisco documentation and additional literature are available on Cisco.com. Cisco also provides several ways to obtain technical assistance and other technical resources. These sections explain how to obtain technical information from Cisco Systems.

Cisco.com

You can access the most current Cisco documentation at this URL:

<http://www.cisco.com/univercd/home/home.htm>

You can access the Cisco website at this URL:

<http://www.cisco.com>

(DRAFT LABEL) ALPHA DRAFT - CISCO CONFIDENTIAL

You can access international Cisco websites at this URL:

http://www.cisco.com/public/countries_languages.shtml

Ordering Documentation

You can find instructions for ordering documentation at this URL:

http://www.cisco.com/univercd/cc/td/doc/es_inpk/pdi.htm

You can order Cisco documentation in these ways:

- Registered Cisco.com users (Cisco direct customers) can order Cisco product documentation from the Ordering tool:

<http://www.cisco.com/en/US/partner/ordering/index.shtml>

- Nonregistered Cisco.com users can order documentation through a local account representative by calling Cisco Systems Corporate Headquarters (California, USA) at 408 526-7208 or, elsewhere in North America, by calling 800 553-NETS (6387).

Documentation Feedback

You can send comments about technical documentation to bug-doc@cisco.com.

You can submit comments by using the response card (if present) behind the front cover of your document or by writing to the following address:

Cisco Systems
Attn: Customer Document Ordering
170 West Tasman Drive
San Jose, CA 95134-9883

We appreciate your comments.

Obtaining Technical Assistance

For all customers, partners, resellers, and distributors who hold valid Cisco service contracts, Cisco Technical Support provides 24-hour-a-day, award-winning technical assistance. The Cisco Technical Support Website on Cisco.com features extensive online support resources. In addition, Cisco Technical Assistance Center (TAC) engineers provide telephone support. If you do not hold a valid Cisco service contract, contact your reseller.

Cisco Technical Support Website

The Cisco Technical Support Website provides online documents and tools for troubleshooting and resolving technical issues with Cisco products and technologies. The website is available 24 hours a day, 365 days a year at this URL:

<http://www.cisco.com/techsupport>

Access to all tools on the Cisco Technical Support Website requires a Cisco.com user ID and password. If you have a valid service contract but do not have a user ID or password, you can register at this URL:

<http://tools.cisco.com/RPF/register/register.do>

Submitting a Service Request

Using the online TAC Service Request Tool is the fastest way to open S3 and S4 service requests. (S3 and S4 service requests are those in which your network is minimally impaired or for which you require product information.) After you describe your situation, the TAC Service Request Tool automatically provides recommended solutions. If your issue is not resolved using the recommended resources, your service request will be assigned to a Cisco TAC engineer. The TAC Service Request Tool is located at this URL:

<http://www.cisco.com/techsupport/servicerequest>

For S1 or S2 service requests or if you do not have Internet access, contact the Cisco TAC by telephone. (S1 or S2 service requests are those in which your production network is down or severely degraded.) Cisco TAC engineers are assigned immediately to S1 and S2 service requests to help keep your business operations running smoothly.

To open a service request by telephone, use one of the following numbers:

Asia-Pacific: +61 2 8446 7411 (Australia: 1 800 805 227)

EMEA: +32 2 704 55 55

USA: 1 800 553 2447

For a complete list of Cisco TAC contacts, go to this URL:

<http://www.cisco.com/techsupport/contacts>

Definitions of Service Request Severity

To ensure that all service requests are reported in a standard format, Cisco has established severity definitions.

Severity 1 (S1)—Your network is “down,” or there is a critical impact to your business operations. You and Cisco will commit all necessary resources around the clock to resolve the situation.

Severity 2 (S2)—Operation of an existing network is severely degraded, or significant aspects of your business operation are negatively affected by inadequate performance of Cisco products. You and Cisco will commit full-time resources during normal business hours to resolve the situation.

Severity 3 (S3)—Operational performance of your network is impaired, but most business operations remain functional. You and Cisco will commit resources during normal business hours to restore service to satisfactory levels.

Severity 4 (S4)—You require information or assistance with Cisco product capabilities, installation, or configuration. There is little or no effect on your business operations.

(DRAFT LABEL) ALPHA DRAFT - CISCO CONFIDENTIAL

Obtaining Additional Publications and Information

Information about Cisco products, technologies, and network solutions is available from various online and printed sources.

- Cisco Marketplace provides a variety of Cisco books, reference guides, and logo merchandise. Visit Cisco Marketplace, the company store, at this URL:
<http://www.cisco.com/go/marketplace/>
- The Cisco *Product Catalog* describes the networking products offered by Cisco Systems, as well as ordering and customer support services. Access the Cisco Product Catalog at this URL:
<http://cisco.com/univercd/cc/td/doc/pcat/>
- *Cisco Press* publishes a wide range of general networking, training and certification titles. Both new and experienced users will benefit from these publications. For current Cisco Press titles and other information, go to Cisco Press at this URL:
<http://www.ciscopress.com>
- *Packet* magazine is the Cisco Systems technical user magazine for maximizing Internet and networking investments. Each quarter, Packet delivers coverage of the latest industry trends, technology breakthroughs, and Cisco products and solutions, as well as network deployment and troubleshooting tips, configuration examples, customer case studies, certification and training information, and links to scores of in-depth online resources. You can access Packet magazine at this URL:
<http://www.cisco.com/packet>
- *iQ Magazine* is the quarterly publication from Cisco Systems designed to help growing companies learn how they can use technology to increase revenue, streamline their business, and expand services. The publication identifies the challenges facing these companies and the technologies to help solve them, using real-world case studies and business strategies to help readers make sound technology investment decisions. You can access iQ Magazine at this URL:
<http://www.cisco.com/go/iqmagazine>
- *Internet Protocol Journal* is a quarterly journal published by Cisco Systems for engineering professionals involved in designing, developing, and operating public and private internets and intranets. You can access the Internet Protocol Journal at this URL:
<http://www.cisco.com/ipj>
- World-class networking training is available from Cisco. You can view current offerings at this URL:
<http://www.cisco.com/en/US/learning/index.html>



Product Overview

This chapter provides physical and functional overviews of the Cisco 7206 router. It contains physical descriptions of the router hardware and major components, and functional descriptions of hardware-related features. Descriptions and examples of software commands are included only when they are necessary for replacing, installing, configuring, or maintaining the router hardware.

The following sections describe the Cisco 7206:

- [Physical Description, page 1-2](#)
- [System Specifications, page 1-5](#)
- [Software Requirements, page 1-6](#)
- [Field-Replaceable Units, page 1-7](#)
- [Functional Overview, page 1-28](#)



Note

The Cisco 7206 is also available as a router shelf in a Cisco AS5800 Universal Access Server. For information about the Cisco 7206 as a router shelf in a Cisco AS5800 Universal Access Server, refer to the Cisco AS5800 Universal Access Server documentation listed in the Preface, “[Related Documentation](#)” section on page xiv.

The Cisco 7206 is part of the Cisco 7200 series routers, which consists of the 2-slot Cisco 7202, 4-slot Cisco 7204 and Cisco 7204VXR, and 6-slot Cisco 7206 and Cisco 7206VXR. The Cisco 7206 supports multiprotocol, multimedia routing and bridging over a wide variety of LAN and WAN interface types.

Network interfaces reside on port adapters that provide the connection between the router’s three Peripheral Component Interconnect (PCI) buses and external networks. The Cisco 7206 has six slots (slot 1 through slot 6) for the port adapters, one slot for an input/output (I/O) controller, and one slot for a network processing engine. You can place the port adapters in any of the six available slots.

There are bays for up to two AC-input or DC-input power supplies. The Cisco 7206 will operate with one power supply. While a second power supply is not required, it allows load sharing and increased system availability.



Note

The Cisco 7206 does not support a mixture of AC- and DC-input power.

The Cisco 7206 provides the following features:

- Online insertion and removal (OIR)—Allows you to add, replace, or remove port adapters without interrupting the system or entering any console commands.
- Dual hot-swappable, load-sharing power supplies—Provide system power redundancy; if one power supply or power source fails, the other power supply maintains system power without interruption. Also, when one power supply is powered off and removed from the router, the second power supply immediately takes over the router's power requirements without interrupting normal operation of the router.
- Environmental monitoring and reporting functions—Allow you to maintain normal system operation by resolving adverse environmental conditions prior to loss of operation.
- Downloadable software—Allows you to load new images into Flash memory remotely, without having to physically access the Cisco 7206 router, for fast, reliable upgrades.

Physical Description

The front of the Cisco 7206 provides access to an I/O controller and up to six network interface port adapters (see [Figure 1-1](#)). The I/O controller contains the following: a local console port for connecting a data terminal (or data terminal equipment [DTE]) and an auxiliary port for connecting a modem (or other data communications equipment [DCE]) or other devices for configuring and managing the router; two PC Card slots for Flash memory cards; an optional Fast Ethernet port. The Fast Ethernet port provides a 100-Mbps connection to the network.



Note

The I/O controller is available with or without a Fast Ethernet port. The I/O controller with a Fast Ethernet port is equipped with either a single MII port or an MII port and an RJ-45 port (only one port can be used at a time). Although still supported by Cisco Systems, the I/O controller equipped with the single MII port was discontinued as an orderable product in May 1998.

Figure 1-1 Cisco 7206 Router—Front View

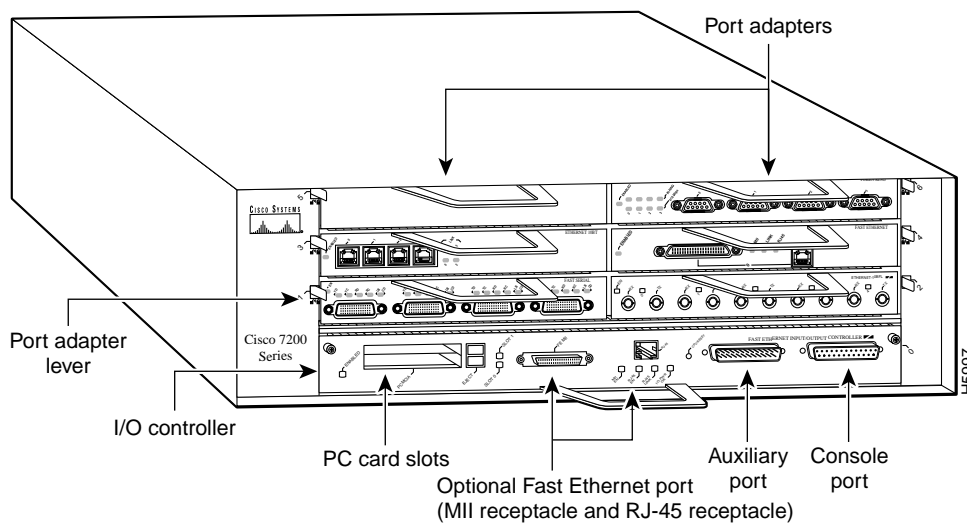

The port adapters installed in the Cisco 7206 are of the same type as those installed on the second-generation Versatile Interface Processors (VIP2s) in the Cisco 7500 series routers, in Cisco 7000 series routers using the 7000 Series Route Switch Processor (RSP7000) and 7000 series Chassis Interface (RSP7000CI), and in the Cisco uBR7200 series routers. The port adapters installed in the Cisco 7206 support OIR. For an explanation of OIR, refer to the “[Online Insertion and Removal](#)” section on page 1-30.

**Note**

The I/O controller does not support OIR. You *must* power down the Cisco 7206 before removing the I/O controller from the router.

Port adapter slots in the Cisco 7206 router are numbered from left to right, beginning with port adapter slot 1 and continuing through port adapter slot 6. Port adapter slot 0 is the Fast Ethernet port on the I/O controller (refer to [Figure 1-2](#)).

**Note**

In [Figure 1-1](#) and [Figure 1-2](#), a blank port adapter is installed in slot 5. To ensure adequate airflow across the port adapters, each port adapter slot must be filled with either a port adapter or a blank port adapter.

Figure 1-2 Port Adapter Slot Numbering

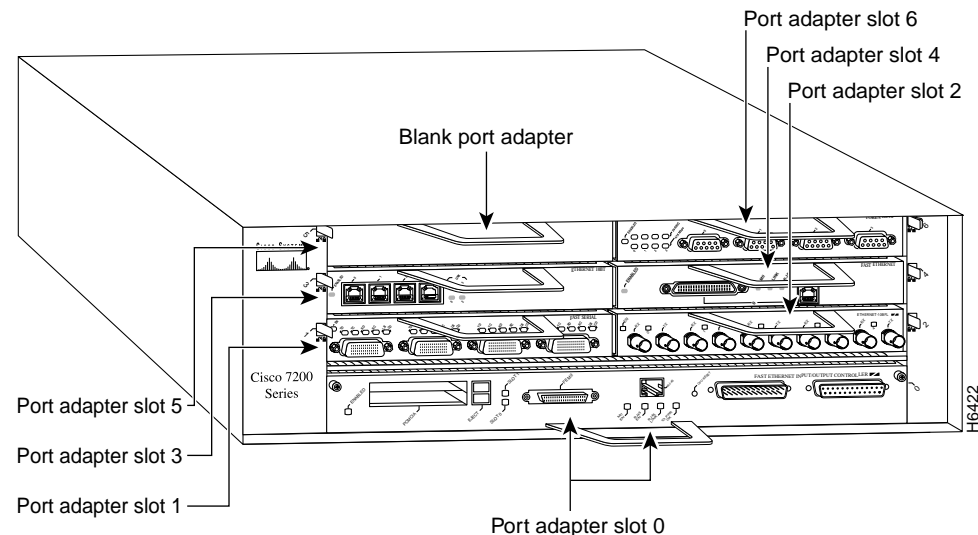

The rear of the Cisco 7206 router provides access to the network processing engine and up to two power supplies (refer to [Figure 1-3](#)).

Figure 1-3 Cisco 7206 Router—Rear View

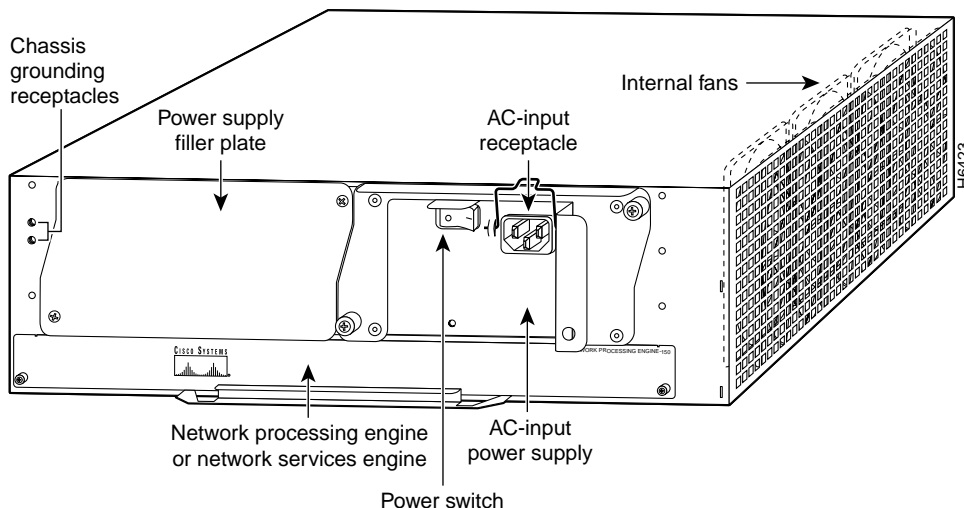
**Note**

The network processing engine does not support OIR. You *must* power down the Cisco 7206 before removing the network processing engine from the router.

The network processing engine has no external connectors or LEDs. There is a handle for removing and installing the network processing engine and two captive installation screws for securing it to the chassis.

The Cisco 7206 router comes equipped with one 280W AC-input or one 280W DC-input power supply. A fully configured Cisco 7206 router operates with only one installed power supply; however, a second, optional power supply of the same type provides hot-swappable, load-sharing, redundant power.

Figure 1-3 shows the rear of a Cisco 7206 router configured with a single AC-input power supply. (A power supply filler plate is installed over the second power supply bay.)

**Caution**

Do not mix power supplies in the Cisco 7206. In dual power supply router configurations, both power supplies *must* be of the same type (two AC-input power supplies or two DC-input power supplies).

The power supply has the router's main power switch and either an AC-input power receptacle or a hardwired DC-input power cable (depending on the type of installed power supply).

Adjacent to the power supply bays are two chassis grounding receptacles that provide a chassis ground connection for ESD equipment or a two-hole grounding lug (refer to Figure 1-3).

Three internal fans draw cooling air into the chassis and across internal components to maintain an acceptable operating temperature. (Refer to Figure 1-3.) The three fans are enclosed in a tray that is located in the subchassis.

**Caution**

To ensure the proper flow of cooling air across the internal components, make sure blank port adapters are installed in unoccupied port adapter slots, and power supply filler plates are installed in unoccupied power supply bays.

The I/O controller, port adapters, power supplies, and network processing engine slide into their respective chassis slots and connect directly to the router midplane; there are no internal cables to connect. The midplane distributes DC power from the power supplies to the I/O controller, port adapters, fan tray, and network processing engine.

The midplane also senses OIR of the port adapters, bridges the PCI buses from the port adapters to packet static random-access memory (SRAM) on the network processing engine, arbitrates traffic across the PCI buses, and generates the clock signals for the port adapters on each PCI bus.

The Cisco 7206 operates as either a tabletop or rack-mounted unit. A rack-mount kit is standard equipment included with all Cisco 7206 routers when they are shipped from the factory. The kit provides the hardware needed to mount the router in a standard 19-inch equipment rack or a 2-post rack. Steps for installing the Cisco 7206 router in an equipment rack are explained in [Chapter 3, “Installing the Cisco 7206,”](#) the [“Rack-Mounting the Cisco 7206”](#) section on page 3-2. If you are not rack-mounting your Cisco 7206, place it on a sturdy tabletop or platform.

A fully configured Cisco 7206, with two installed power supplies and all chassis slots filled, weighs approximately 50 pounds (22.7 kilograms [kg]). For clearance requirements and rack-mount installation considerations, refer to [Chapter 2, “Preparing for Installation,”](#) the [“Site Requirements”](#) section on page 2-2.

System Specifications

[Table 1-1](#) lists the Cisco 7206 router physical specifications and power requirements.

Table 1-1 Cisco 7206 Physical Specifications

Description	Specification
Midplane	Two primary PCI buses and one secondary PCI bus with an aggregate bandwidth of 600 Mbps ¹
Dimensions (H x W x D)	5.25 in. x 16.8 in. x 17 in. (13.34 cm x 42.67 cm x 43.18 cm)
Weight	Chassis fully configured with a network processing engine, I/O controller, 6 port adapters, 2 power supplies, and a fan tray: ~ 50 lb (22.7 kg)
Heat dissipation	370W (1262 Btu ²)
AC-input voltage rating	100–240 VAC ³ wide input with power factor correction
AC-input current rating	5A ⁴ at 100–240 VAC with the chassis fully configured
AC-input frequency rating	50/60 Hz ⁵
AC-input cable	18 AWG ⁶ three-wire cable, with a three-lead IEC-320 receptacle on the power supply end, and a country-dependent plug on the power source end
DC-output power	280W maximum (with either a single or a dual power supply configuration)
DC-input voltage rating	–48 VDC ⁷ nominal in North America –60 VDC nominal in the European Union
DC-input current rating	13A at –48 VDC (370W/–48 VDC = 7.7A typical draw) 8A at –60 VDC (370W/–60 VDC = 6.2A typical draw)

Table 1-1 Cisco 7206 Physical Specifications (continued)

Description	Specification
DC voltages supplied and maximum, steady-state current ratings	+5.2V @ 30A +12.2V @ 9A -12.0V @ 1.5A +3.5V @ 13A
DC-input cable	In accordance with local and national wiring regulations
Airflow	~80 cfm ⁸
Temperature	32 to 104°F (0 to 40°C) operating; -4 to 149°F (-20 to 65°C) nonoperating
Humidity	10 to 90% noncondensing

1. Mbps = megabits per second.
2. Btu = British thermal units.
3. VAC = volts alternating current.
4. A = amperes.
5. Hz = hertz.
6. AWG = American Wire Gauge.
7. VDC = volts direct current.
8. cfm = cubic feet per minute.

**Note**

For a chassis footprint, additional dimensions, and clearance requirements for the Cisco 7206 perimeter, refer to [Chapter 2, “Preparing for Installation,”](#) the “Site Requirements” section on page 2-2.

Software Requirements

Cisco IOS requirements for the Cisco 7206 are listed below:

- Cisco IOS Release 11.1(17)CA or a later release of Cisco IOS 11.1 CA
- Cisco IOS Release 11.2(12)P or a later release of Cisco IOS 11.2 P
- Cisco IOS Release 11.3(2)T or a later release of Cisco IOS 11.3 T
- Cisco IOS Release 12.0(3)T or a later release of Cisco IOS 12.0 T

**Note**

For software information for the Cisco AS5800 Universal Access Server, refer to the Cisco AS5800 Universal Access Server documentation listed on Cisco.com at http://www.cisco.com/univercd/cc/td/doc/product/access/acs_serv/as5800/index.htm.

Field-Replaceable Units

The Cisco 7206 router is easy to service; all its major components are field replaceable units (FRUs). The following sections describe Cisco 7206 FRUs:

- [Network Processing Engine, page 1-7](#)
- [Input/Output Controller, page 1-14](#)
- [LED Descriptions, page 1-18](#)
- [Port Adapters and Service Adapters, page 1-24](#)
- [Power Supplies, page 1-24](#)
- [Chassis, page 1-26](#)
- [Flash Disks and Flash Memory Cards, page 1-27](#)
- [Rack-Mount and Cable-Management Kit, page 1-28](#)

**Note**

Instructions for removing and replacing FRUs are contained in separate documents. For example, if you need to replace the network processing engine (NPE) in your Cisco 7206 router, refer to the *Network Processing Engine and Network Services Engine Installation and Configuration* document that accompanies every NPE shipped from the factory as a FRU. The document is available on Cisco.com

For ordering information, contact a customer service representative.

Network Processing Engine

The network processing engine maintains and executes the system management functions for the Cisco 7206 router. The network processing engine also shares the system memory and environmental monitoring functions with the I/O controller.

**Note**

Detailed instructions for removing and replacing the network processing engine are contained in the document *Network Processing Engine and Network Services Engine Installation and Configuration* document which is available on Cisco.com.

Cisco 7206 routers support five versions of the network processing engine: NPE-100, NPE-150, NPE-175, NPE-200, and NPE-225. These network processing engines have the same functionality; however, the performance differs because of the microprocessor type and the type of memory for packet data (SRAM and DRAM, or SDRAM) each network processing engine provides.

The NPE-175 and NPE-225 consist of two modular boards: the processor engine board and the network controller board. SRAM is not included in the NPE-175 or NPE-225.

**Note**

The NPE-100, although still supported, is no longer an orderable product as of May 1999.

**Note**

The Cisco 7206 as a router shelf in a Cisco AS5800 Universal Access Server only supports the NPE-200.

The network processing engines consist of the following components:

- Reduced instruction set computing (RISC) microprocessor
 - The NPE-100 and NPE-150 have an R4700 microprocessor that operates at an internal clock speed of 150 MHz.
 - The NPE-175 has an RM5270 microprocessor that operates at an internal clock speed of 200 MHz.
 - The NPE-200 has an R5000 microprocessor that operates at an internal clock speed of 200 MHz.
 - The NPE-225 has an RM5271 microprocessor that operates at an internal clock speed of 262 MHz.
- System controller
 - The NPE-100, NPE-150, and NPE-200 have a system controller that uses direct memory access (DMA) to transfer data between DRAM and packet SRAM on the network processing engine.
 - The NPE-175 and NPE-225 have one system controller that provides processor access to the two midplane and single I/O controller PCI buses. The system controller also allows port adapters on either of the two midplane PCI buses to access SDRAM.
- Upgradable memory modules
 - The NPE-100, NPE-150, and NPE-200 use DRAM for storing routing tables, network accounting applications, packets of information in preparation for process switching, and packet buffering for SRAM overflow (except in the NPE-100, which contains no packet SRAM). The standard configuration is 32 MB, with up to 128 MB available through single in-line memory module (SIMM) upgrades.
 - The NPE-175 and NPE-225 use SDRAM for providing code, data, and packet storage.
- Packet SRAM for storing packets of information in preparation for fast switching
 - The NPE-100 does not have packet SRAM.
 - The NPE-150 has 1 MB of SRAM.
 - The NPE-175 does not have packet SRAM.
 - The NPE-200 has 4 MB of SRAM.
 - The NPE-225 does not have packet SRAM.
- Cache memory
 - The NPE-100, NPE-150, and NPE-200 have unified cache SRAM that functions as the secondary cache for the microprocessor. (The primary cache is within the microprocessor.)
 - The NPE-175 and NPE-225 have two levels of cache: a primary that is internal to the processor and a secondary, 2-MB external cache that provides additional high-speed storage for data and instructions.
- Two environmental sensors for monitoring the cooling air as it leaves the chassis
- Boot ROM for storing sufficient code for booting the Cisco IOS software; the NPE-175, NPE-200, and NPE-225 have a boot ROM

The network processing engines perform the following system management functions:

- Sending and receiving routing protocol updates
- Managing tables, caches, and buffers
- Monitoring interface and environmental status
- Providing Simple Network Management Protocol (SNMP) management through the console and Telnet interface
- Accounting for and switching of data traffic
- Booting and reloading images
- Managing port adapters (recognition and initialization during online insertion and removal)

Figure 1-4 shows the NPE-100, Figure 1-5 shows the NPE-150, Figure 1-6 shows the NPE-175, Figure 1-7 shows the NPE-200, and Figure 1-8 shows the NPE-225.

Figure 1-4 NPE-100

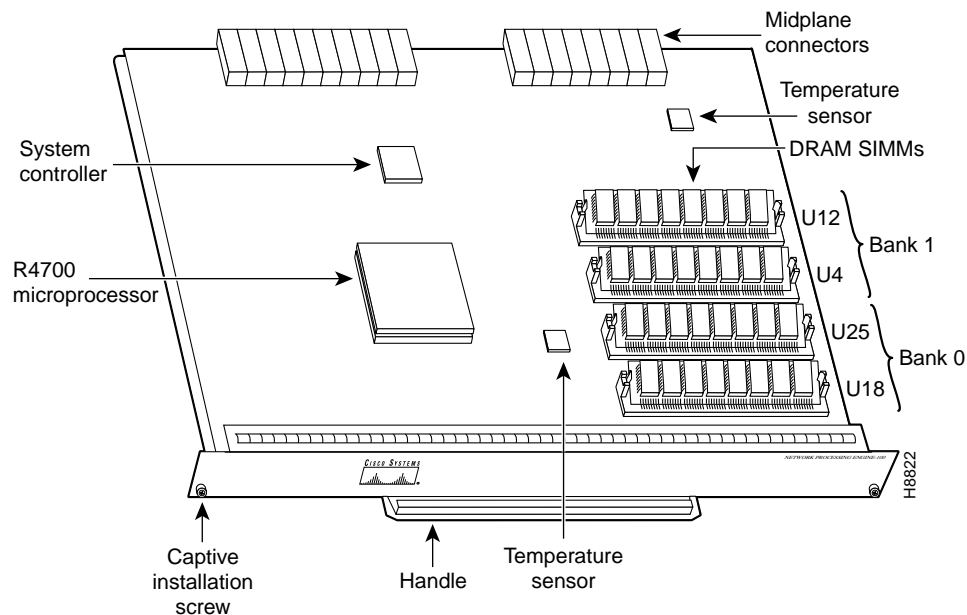

Figure 1-5 NPE-150

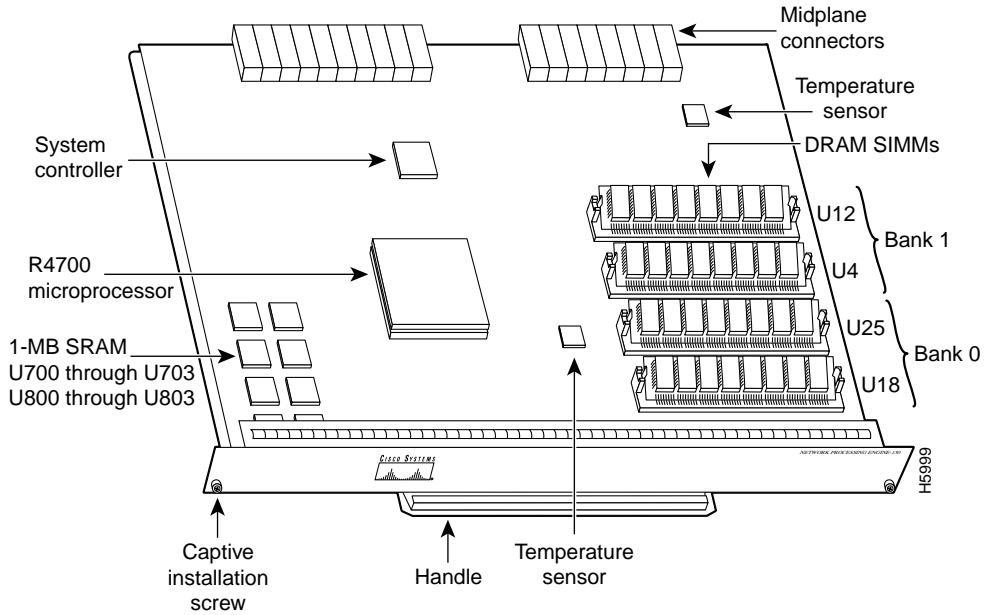

Figure 1-6 NPE-175

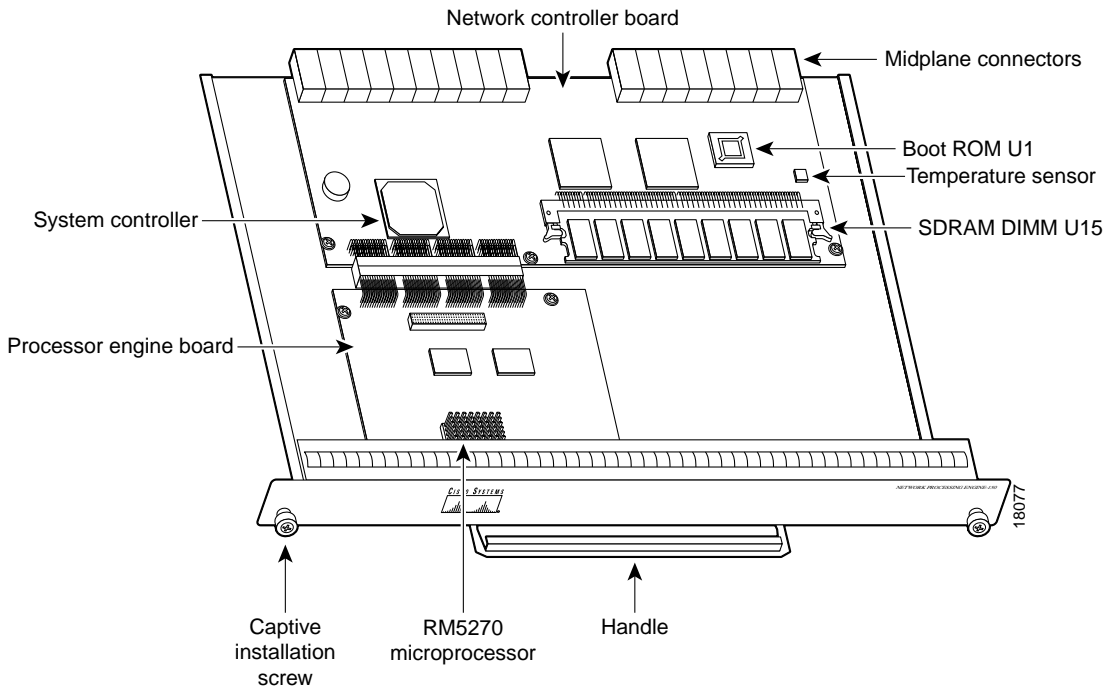

Figure 1-7 NPE-200

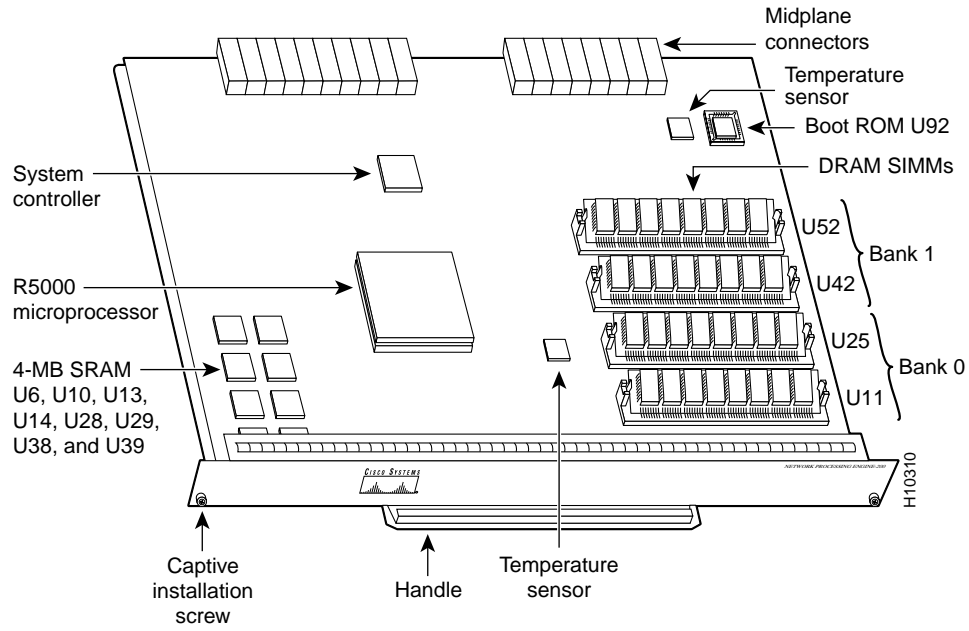

Figure 1-8 NPE-225

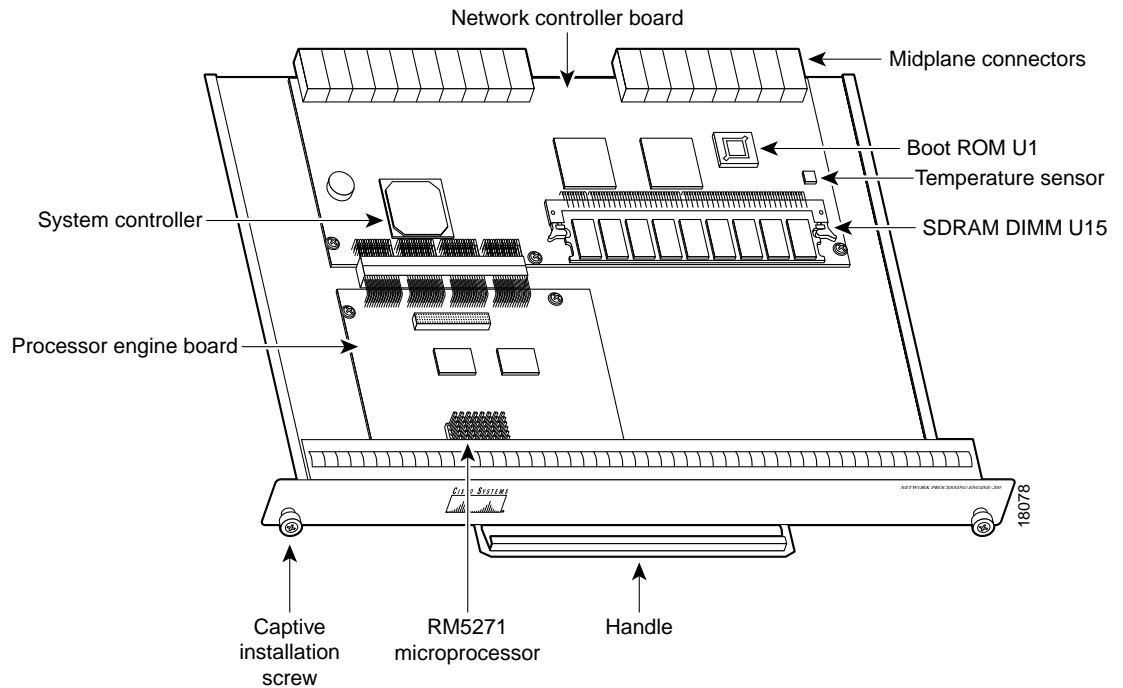

Table 1-2 lists the NPE-100, NPE-150, and NPE-200 network processing engine memory specifications.

Table 1-2 Network Processing Engine Memory Specifications (NPE-100, NPE-150, and NPE-200)

Memory Type	Size	Quantity	Description	Location
DRAM	32 to 128 MB	2 to 4	16- or 32-MB SIMMs (based on maximum DRAM required)	Bank 0: U18 and U25 or U11 and U25 ¹ Bank 1: U4 and U12 or U42 and U52 ²
SRAM				
NPE-150	1 MB	8	8 chips, each being 128K words x 9 bits wide	U700 through U703 U800 through U803
NPE-200	4 MB	8	8 chips, each being 512K words x 8 bits wide	U6, U10, U13, U14, U28, U29, U38, and U39
Boot ROM ³				
NPE-200	256 KB	1	EPROM for the ROM monitor program	U92
Primary cache	—	—	R4700 processor, internal cache R5000 processor, internal cache	NPE-100, NPE-150: U201 NPE-200: U44
Secondary cache	512 KB	4	R4700, unified external cache R5000, unified external cache	NPE-100 and NPE-150: U2, U10, U14, and U26 NPE-200: U16, U9, U109, and U107

1. The sockets for bank 0 on the NPE-100 and the NPE-150 are numbered U18 and U25. The same sockets on the NPE-200 are numbered U11 and U25.
2. The sockets for bank 1 on the NPE-100 and the NPE-150 are numbered U4 and U12. The same sockets on the NPE-200 are numbered U42 and U52.
3. ROM = read-only memory. The NPE-100 and NPE-150 use the boot ROM present on the I/O controller.

**Note**

To prevent DRAM errors in the NPE-100, NPE-150, or NPE-200, and to ensure that your system initializes correctly at startup, DRAM bank 0 (socket U18 and U25, or U11 and U25) *must* contain no fewer than two SIMMs of the same type. You may also install two SIMMs of the same type in bank 1 (socket U4 and U12, or U42 and U52); however, bank 0 must always contain the two largest SIMMs.

Table 1-3 lists the NPE-175 and NPE-225 memory specifications.

Table 1-3 NPE-175 and NPE-225 Memory Specifications

Memory Type	Size	Quantity	Description	Location ¹
SDRAM	64 or 128 MB	1 configurable bank with 1 SDRAM slot	DIMM	U15
Boot ROM	512 KB	—	One-time programmable ROM	U1

Table 1-3 NPE-175 and NPE-225 Memory Specifications (continued)

Memory Type	Size	Quantity	Description	Location ¹
Primary cache	16 KB (instruction), 16 KB (data)	—	R527x processor primary internal cache	U4
	32 KB (instruction), 32 KB (data)	—	R527x processor primary internal cache	U4
Secondary cache	2 MB	4 chips, each 512K by 8 bits wide	R527x unified external cache	U5, U6, U7, U8

1. Located on processor engine board. (See [Figure 1-6](#) or [Figure 1-8](#).)

[Table 1-4](#) lists the NPE-100, NPE-150, and NPE-200 factory-installed DRAM configurations and their product numbers.

Table 1-4 DRAM SIMM Configurations (NPE-100, NPE-150, and NPE-200)

Total DRAM ¹	DRAM Bank 0	Quantity	DRAM Bank 1	Quantity	Product Number
32 MB	U18 and U25 or U11 and U25	2 16-MB SIMMs	U4 and U12 or U42 and U52	—	MEM-NPE-32MB ²
64 MB	U18 and U25 or U11 and U25	2 32-MB SIMMS	U4 and U12 or U42 and U52	—	MEM-NPE-64MB ²
128 MB	U18 and U25 or U11 and U25	2 32-MB SIMMs	U4 and U12 or U42 and U52	2 32-MB SIMMs	MEM-NPE-128MB ²

1. Refer to the Cisco AS5800 Universal Access Server documentation listed in the Preface, “[Related Documentation](#)” section on [page xiv](#), for Cisco AS5800 Universal Access Server DRAM options.
2. These products are also available as DRAM upgrades. For example, to upgrade a network processing engine from 32 MB to 64 MB of DRAM, order Product Number MEM-NPE-64MB=.

[Table 1-5](#) lists the NPE-175 and NPE-225 SDRAM DIMM configurations.

Table 1-5 NPE-175 and NPE-225 SDRAM DIMM Configurations

Total DRAM	DRAM Bank	Quantity	Product Number
64 MB	U15	1 64-MB DIMM	MEM-SD-NPE-64MB
128 MB	U15	1 128-MB DIMM	MEM-SD-NPE-128MB

Use the **show version** command to identify the network processing engine installed in your Cisco 7206 router. The following example shows an installed NPE-150:

```
Router> show version
Cisco Internetwork Operating System Software
IOS (tm) 7200 Software (C7200-J-M), Released Version 11.1(17)CA
Copyright (c) 1986-1996 by cisco Systems, Inc.
Compiled Sun 04-Aug-96 06:00 by biff
Image text-base: 0x60010890, data-base: 0x605F0000

(display text omitted)
```

```
cisco 7206 (NPE 150) processor with 12288K/4096K bytes of memory.
R4700 processor, Implementation 33, Revision 1.0 (Level 2 Cache)
Last reset from power-on
Bridging software.
```

(display text omitted)

Input/Output Controller

The I/O controller shares the system memory functions and the environmental monitoring functions for the Cisco 7206 router with the network processing engine. It contains the following components:

- Flash memory for storing the boot helper image
- Two PC Card slots for Flash Disks or Flash memory cards, which contain the default Cisco IOS software image
- Boot ROM for storing sufficient code for booting the Cisco IOS software
- Two environmental sensors for monitoring the cooling air as it enters and leaves the Cisco 7206 chassis



Note

Detailed instructions for removing and replacing the I/O controller are contained in the *Input/Output Controller Replacement Instructions* document. This document is available on Cisco.com.

The I/O controller is available in these versions: C7200-I/O-FE-MII, C7200-I/O-FE=.

- The C7200-I/O-FE-MII and C7200-I/O-FE= I/O controllers consists of the following components:
 - Dual EIA/TIA-232 channels for local console and auxiliary ports. The console port has full DCE functionality and a DB-25 port. The auxiliary port has full DTE functionality and a DB-25 plug.
 - An optional Fast Ethernet port that is configurable for use at 100 megabits per second (Mbps) full-duplex or half-duplex (half-duplex is the default). The Fast Ethernet port is equipped with either an MII port and an RJ-45 port (C7200-I/O-FE=) (see [Figure 1-9](#)), or a single MII port (C7200-I/O-FE-MII=) (see [Figure 1-11](#)). Although still supported by Cisco Systems, the I/O controller equipped with the single MII port (C7200-I/O-FE-MII=) is no longer an orderable product as of May 1998. The I/O controller without the Fast Ethernet port (C7200-I/O=) is shown in [Figure 1-10](#).



Note

The I/O controller with the Product Number C7200-I/O-FE-MII= has a single MII Fast Ethernet port only. The Product Number for the I/O controller with two Fast Ethernet ports, C7200-I/O-FE=, does not specify MII because both an MII and an RJ-45 port are included.



Note When you use the I/O controller that is equipped with an MII port and an RJ-45 port (C7200-I/O-FE=), only one port can be configured for use at a time.

You can install an I/O controller with or without a Fast Ethernet port in all Cisco 7200 series routers (including the Cisco 7206 and Cisco 7206VXR as router shelves in a Cisco AS5800 Universal Access Server).

- Nonvolatile random-access memory (NVRAM) for storing the system configuration and environmental monitoring logs.



Note

NVRAM uses lithium batteries to maintain its contents when disconnected from power. Some I/O controllers use an SRAM component with an external lithium battery to provide the same functionality as the NVRAM. (See the second illustration in [Figure 1-9](#) and [Figure 1-10](#).)



Note

Your I/O controller with the Fast Ethernet port that has MII and RJ-45 ports (C7200-I/O-FE=) might look like the first illustration in [Figure 1-9](#), or it might look like the second illustration in [Figure 1-9](#). There is no functional difference between these two I/O controllers with the Fast Ethernet port.

Figure 1-9 C7200-I/O-FE=—with MII and RJ-45 Fast Ethernet Ports

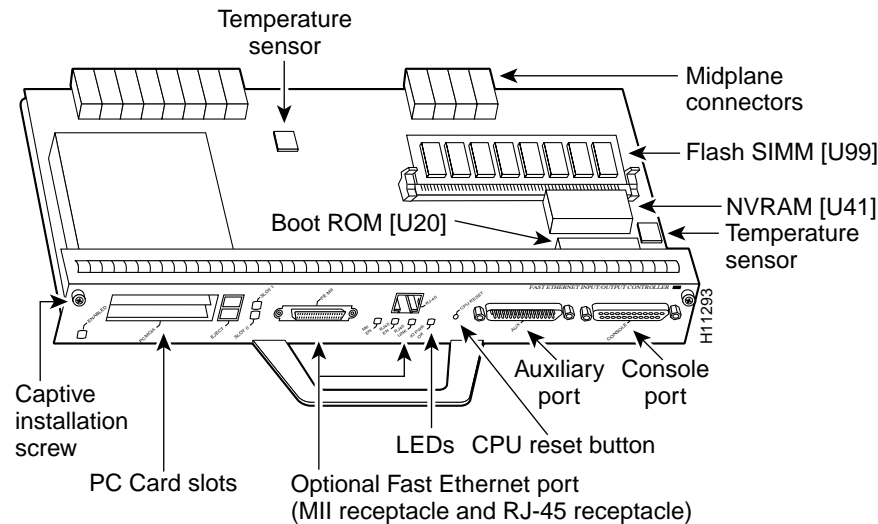

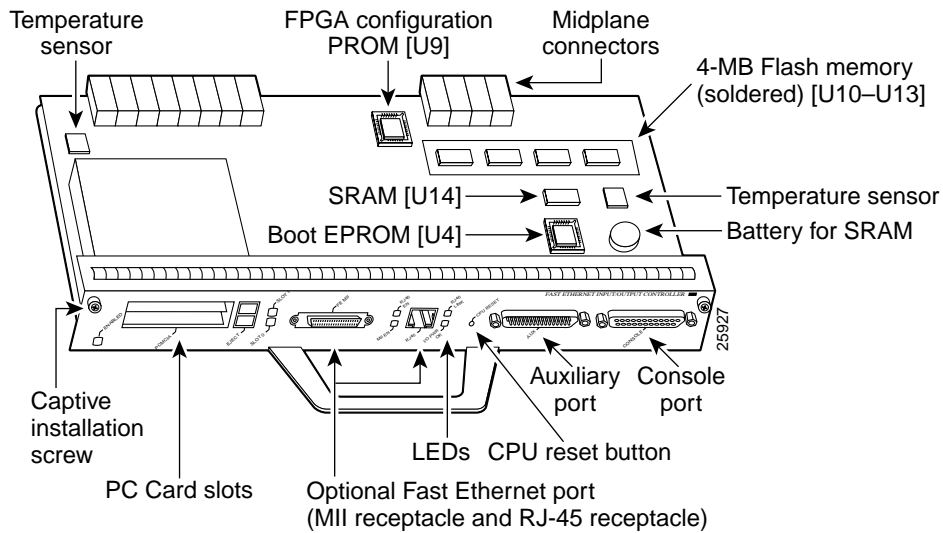
**Note**

Your I/O controller without the Fast Ethernet port (C7200-I/O=) might look like the first illustration in [Figure 1-10](#), or it might look like the second illustration in [Figure 1-10](#). There is no functional difference between these two I/O controllers without the Fast Ethernet port.

Figure 1-10 C7200-I/O=—Without Fast Ethernet Port

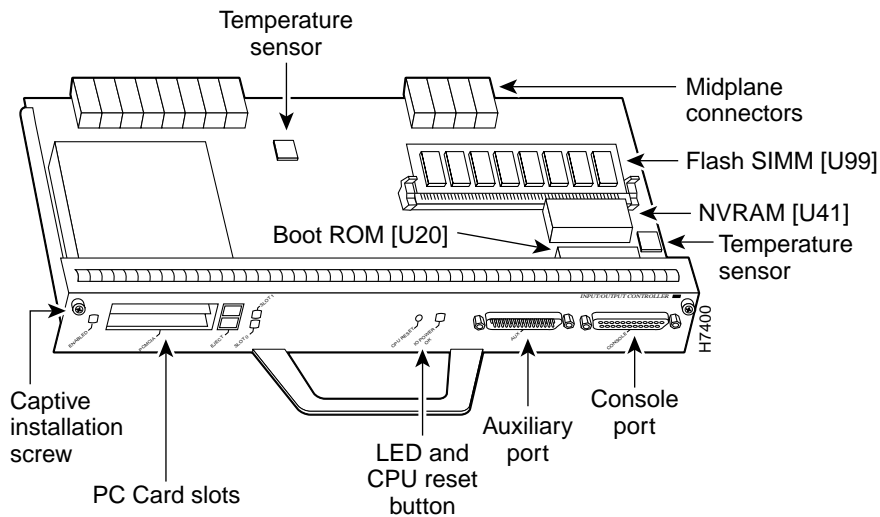

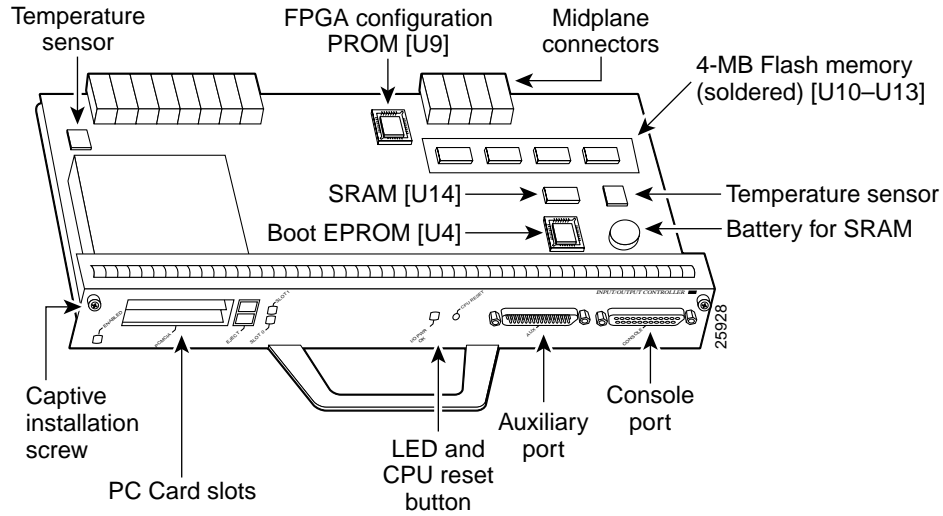

Figure 1-11 C7200-I/O-FE-MII-1 with Single MII Fast Ethernet Port

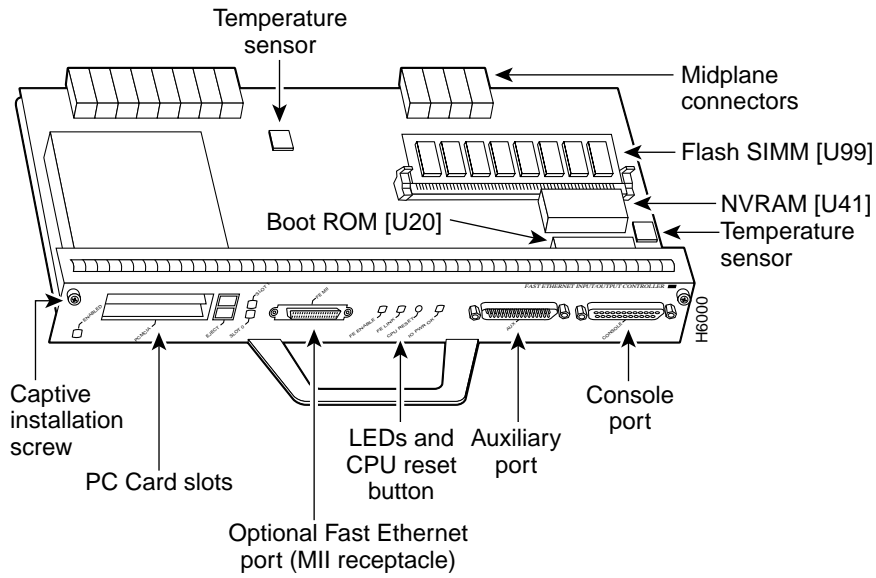

Table 1-6 lists the I/O controller memory components.

Table 1-6 I/O Controller Memory Components

Memory Type	Size	Quantity	Description	Model	Location
Boot ROM	256 KB	1	32-pin DIP-type	C7200-I/O-FE-MII	U20
			32-pin DIP-type or 32-pin PLCC-type	C7200-I/O-FE, C7200-I/O	U20 or U4
Flash memory	4 MB	1	Contains the default boot helper image	C7200-I/O-FE-MII	U99
				C7200-I/O-FE, C7200-I/O	U99 or U10, U11, U12, and U13 (soldered ¹)
Flash memory card	20 MB	Up to 2	Contains the default Cisco IOS image	All models	PC Card slot 0 and slot 1
Flash Disk	48 to 128 MB	Up to 2			
NVRAM ²	128 KB	1	Nonvolatile EPROM for the system configuration file	C7200-I/O-FE-MII	U41
				C7200-I/O-FE, C7200-I/O	U41 or U14 (soldered) ²

1. Some I/O controllers have no Flash SIMM but use a permanently fixed 4-MB Flash chip instead. (See [Figure 1-9](#).)
2. The NVRAM on some I/O controllers is replaced by a 32-pin nonsocketed SRAM component that is soldered onto the card. The SRAM component is made to act like the NVRAM by the addition of some external components, one of which is a 1-inch (2.54-cm) button-type lithium battery.

LED Descriptions

[Figure 1-12](#) shows the LEDs on the I/O controller with the Fast Ethernet port that is equipped with an MII port and an RJ-45 port. [Figure 1-13](#) shows the LEDs on the I/O controller without the Fast Ethernet port. [Figure 1-14](#) shows the LEDs on the I/O controller with the Fast Ethernet port that is equipped with a single MII port.

[Table 1-7](#) lists I/O controller LEDs and their functions. To use the LEDs for troubleshooting the I/O controller, refer to [Chapter 6, “Troubleshooting the Installation,”](#) the “[Troubleshooting the I/O Controller](#)” section on page 6-6.

A CPU reset button is located next to the IO power OK LED or the auxiliary port on the I/O controller faceplate. The CPU reset button resets the entire system.



Caution

To prevent system errors and problems, use the CPU reset button only at the direction of your service representative.

Figure 1-12 C7200-I/O-FE—LEDs and CPU Reset Button—with Fast Ethernet Port (MII and RJ-45 Ports)

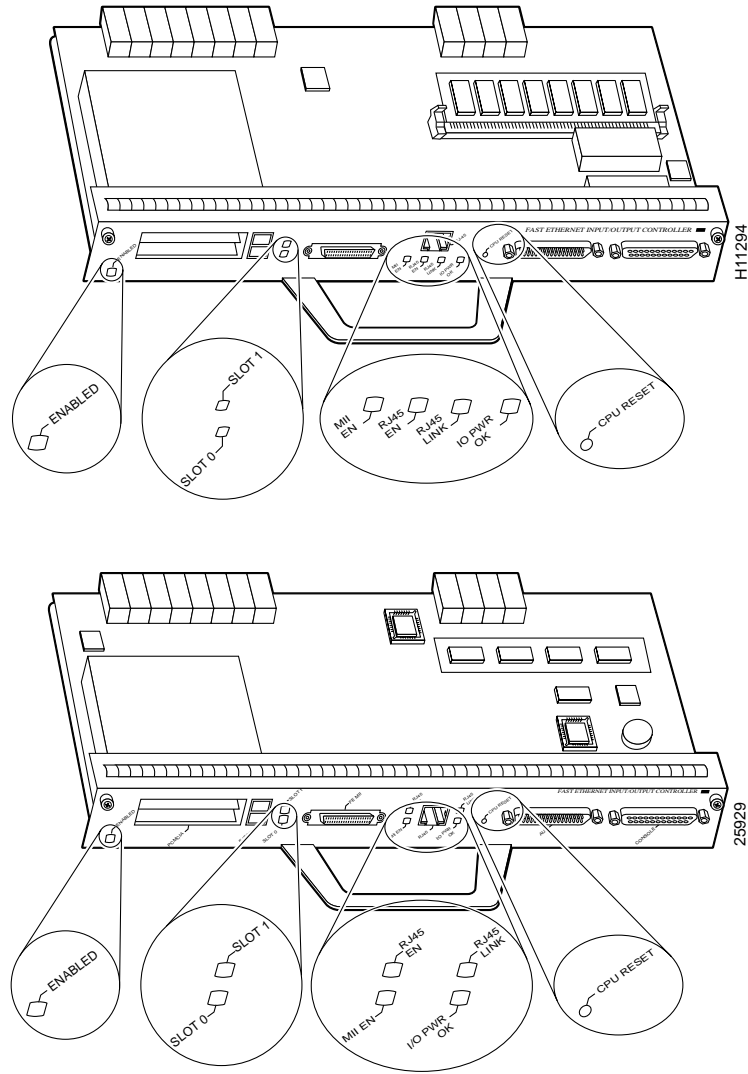

Figure 1-13 C7200-I/O—LEDs and CPU Reset Button—without Fast Ethernet Port

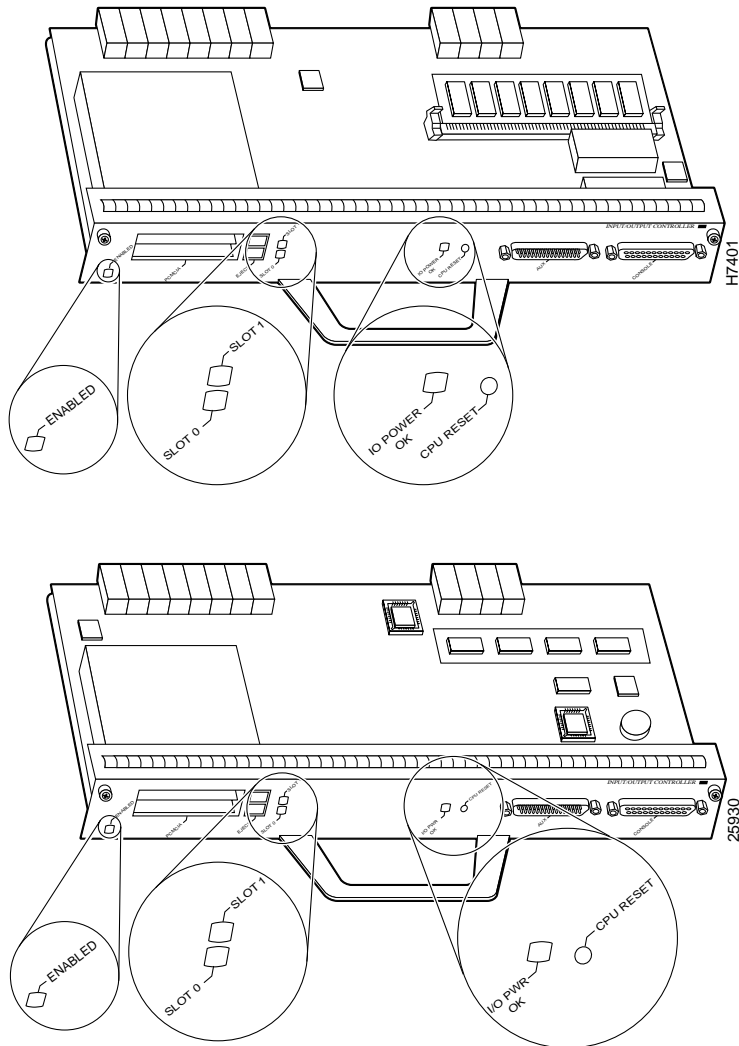
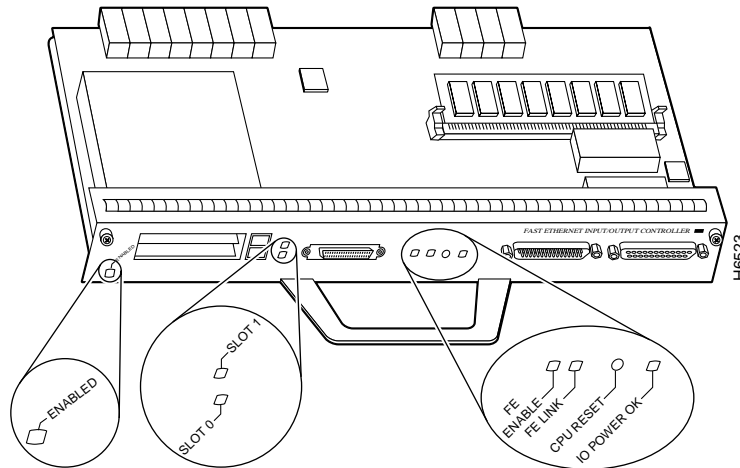

Figure 1-14 C7200-I/O-FE—LEDs and CPU Reset Button—with Fast Ethernet Port (Single MII Port)



LEDs are either on or off. The LED state (on or off), not the color, determines the status of connection as described in [Table 1-7](#). However, most LEDs are green when on, with the exception of the IO POWER OK LED, which is orange when in the on state.

Table 1-7 I/O Controller LEDs

LED	Color	Function
ENABLED	Green	Indicates that the network processing engine and the I/O controller are enabled for operation by the system; however, it does not mean that the Fast Ethernet port on the I/O controller is functional or enabled. This LED comes on during a successful router boot and remains on during normal operation of the router.
IO POWER OK	Orange	Indicates that the I/O controller is on and receiving DC power from the router midplane. This LED comes on during a successful router boot and remains on during normal operation of the router.
FE ENABLE	Green	Indicates that the Fast Ethernet port is initialized and enabled for operation by the system. This LED comes on after the I/O controller has been enabled and remains on during normal operation of the router.
FE LINK ¹	Green	Indicates that the Fast Ethernet port has established a valid link with the network. This LED remains off during normal operation of the router, unless there is an incoming carrier signal.
MII EN	Green	Indicates that the Fast Ethernet MII port is initialized and enabled by the system, and is configured for operation. This LED comes on after the I/O controller has been enabled and the MII port has been configured as the media type for the Fast Ethernet port (the RJ-45 port is the default media type for the Fast Ethernet port). This LED remains on during normal operation of the router.
RJ45 EN	Green	Indicates that the Fast Ethernet RJ-45 port (the default media type for the Fast Ethernet port) is initialized and enabled by the system. This LED comes on after the I/O controller has been enabled and remains on during normal operation of the router.

Table 1-7 I/O Controller LEDs (continued)

LED	Color	Function
RJ45 LINK	Green	Indicates that the Ethernet or Fast Ethernet RJ-45 port has established a valid link with the network. This LED remains off during normal operation of the router, unless there is an incoming carrier signal.
SLOT 0 SLOT 1	Green	Goes on to indicate which PC Card slot is in use by coming on when either slot is being accessed by the system. These LEDs remain off during normal operation of the router.

1. The FE LINK LED is only found on the I/O controller with the single MII port. (See [Figure 1-14 on page 1-21](#).)

**Note**

The I/O controller without the Fast Ethernet port does not have the FE ENABLE LED and the FE LINK LED. The I/O controller without the Fast Ethernet port and the I/O controller that is equipped with a single MII port do not have the MII EN, RJ-45 EN, and RJ-45 LINK LEDs.

**Note**

An MII LINK LED is not provided on the I/O controller because the LED is provided on external transceivers that are required for connecting to the MII port on the I/O controller. Refer to [Chapter 3, “Installing the Cisco 7206,”](#) the “Fast Ethernet Connection Equipment” section on page 3-16 for Fast Ethernet MII connection requirements.

Use the **show diag 0** command to identify the I/O controller (with or without the Fast Ethernet port) installed in your Cisco 7206 router.

**Note**

Slot 0 in Cisco 7200 series routers is always reserved for the Fast Ethernet port on the I/O controller—if present. If the I/O controller without the Fast Ethernet port is installed in your Cisco 7200 series router, the system software will not display output for the **show diag 0** command.

**Note**

Refer to the “[Port Adapter Slot and Logical Interface Numbering](#)” section on page 1-28 for information about port adapter slot numbering and logical interface numbering for the Cisco 7206 router.

The following example shows the I/O controller with the Fast Ethernet port that is equipped with an MII port and an RJ-45 port:

```
Router> show diag 0
Slot 0:
Fast-ethernet on C7200 I/O with MII or RJ45 port adapter, 1 port
  Port adapter is analyzed
  Port adapter insertion time 00:10:42 ago
  Hardware revision 2.0          Board revision A0
  Serial number 3511336         Part number 73-1537-03
  Test history 0x0             RMA number 00-00-00
  EEPROM format version 1
  EEPROM contents (hex):
    0x20: 01 14 02 00 00 35 94 28 49 06 01 03 00 00 00 00
    0x30: 50 0000 00 FF FF FF FF FF FF FF FF FF FF FF FF
```

The RJ-45 port is the default media type for the I/O controller that is equipped with an MII port and an RJ-45 port. Use the **media-type** command to change the I/O controller's media type and the **show interfaces** command to verify the change. The following example configures the MII port as the media type for the I/O controller:

```
Router# configure terminal
Enter configuration commands, one per line.  End with CNTL/Z.
Router(config)# int fastethernet 0/0
Router(config-if)# media-type mii
Router(config-if)# no shutdown
Router(config-if)# exit
Router(config)#
%LINEPROTO-5-UPDOWN: Line protocol on Interface FastEthernet0/0, changed
state to up
%LINK-3-UPDOWN: Interface FastEthernet0/0, changed state to up

Router# show interfaces fastethernet 0/0
FastEthernet0/0 is administratively up, line protocol is up

    (display text omitted)

    Encapsulation ARPA, loopback not set, keepalive not set, hdx, MII

    (display text omitted)
```

Use the **media-type 100X** command to return the media type to the RJ-45 port.

The default transmission mode for the Fast Ethernet port on the I/O controller is half-duplex. Use the **full-duplex** command to change the Fast Ethernet port's transmission mode and the **show interfaces** command to verify the change as follows:

```
Router# configure terminal
Enter configuration commands, one per line.  End with CNTL/Z.
Router(config)# int fastethernet 0/0
Router(config-if)# full-duplex
Router(config-if)# no shutdown
Router(config-if)# exit
Router(config)#
%LINEPROTO-5-UPDOWN: Line protocol on Interface FastEthernet0/0, changed
state to up
%LINK-3-UPDOWN: Interface FastEthernet0/0, changed state to up

Router# show interfaces fastethernet 0/0
FastEthernet0/0 is administratively up, line protocol is up

    (display text omitted)

    Encapsulation ARPA, loopback not set, keepalive not set, fdx, 100BaseTX

    (display text omitted)
```

Use the **no full-duplex** command to return the Fast Ethernet port on the I/O controller to half-duplex transmission mode.

Port Adapters and Service Adapters

The Cisco 7206 is shipped from the factory with up to six installed port adapters and service adapters. Port adapters provide a variety of network media types (based on your order) for the router and service adapters provide hardware-based services (such as data compression and encryption) for the port adapter media types. The port adapters and service adapters connect directly to the router's midplane. Port adapters and service adapters installed in the Cisco 7206 router support OIR.

For a description of OIR, refer to the "Online Insertion and Removal" section later in this chapter. For general instructions about how to replace a port adapter or service adapter, refer to [Chapter 5](#), "Maintaining the Cisco 7206," the "Replacing a Port Adapter or Service Adapter" section on page 5-4.

**Caution**

To ensure adequate airflow across the router's port adapters, a port adapter or a blank port adapter must be installed in each port adapter slot.

**Note**

Detailed instructions for removing, replacing, and configuring the port adapter and service adapter types supported by the Cisco 7206 are contained in the configuration note for each port adapter and service adapter. For example, if you plan to replace a PA-A3 enhanced ATM port adapter in your Cisco 7206 router, consult the configuration note *PA-A3 Enhanced ATM Port Adapter Installation and Configuration*. The configuration note is available on Cisco.com.

Power Supplies

The Cisco 7206 comes equipped with one 280W AC-input power supply or one 280W DC-input power supply. You must order the second power supply separately.

**Caution**

Do not mix power supplies in the Cisco 7206. In dual power supply configurations, both power supplies *must* be of the same type (two AC-input power supplies or two DC-input power supplies).

**Note**

Detailed instructions for handling and replacing the Cisco 7206 power supplies are contained in the configuration notes *280-Watt AC-Input Power Supply Replacement Instructions* and *280-Watt DC-Input Power Supply Replacement Instructions*. . These configuration notes are available on Cisco.com.

A handle on the AC and DC power supplies provides a grip point for removing and replacing the power supply. (Figure 1-15 shows the faceplate of the AC-input power supply. Figure 1-16 shows the faceplate of the DC-input power supply.) Two captive installation screws secure the power supply to the chassis and seat the power supply in the router midplane. A power OK LED indicates that the power supply is delivering +5 VDC to the router midplane.

The AC-input power supply has a receptacle for an AC-input power cable. A modular power cable connects the AC-input power supply to the site AC power source. A cable-retention clip secures the power cable to the AC-input power supply.

Figure 1-15 Cisco 7206 AC-Input Power Supply

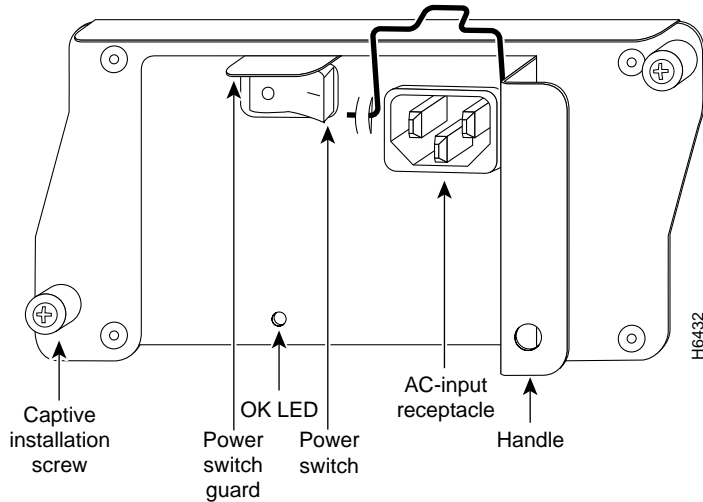

The DC-input power supply has DC-input power leads that are hardwired to a DC-input terminal block. A cable tie is shipped with each DC-input power supply to secure the leads to the power supply faceplate and provide strain relief for the leads.

Figure 1-16 Cisco 7206 DC-Input Power Supply

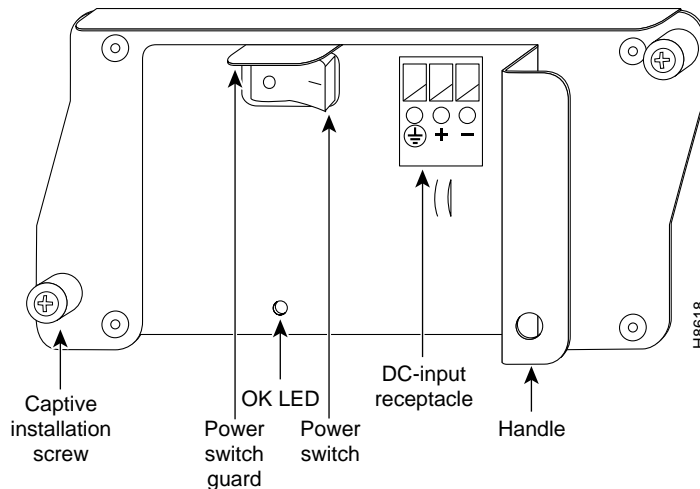

Caution

To ensure adequate airflow across the router power supplies, a power supply or a power supply filler plate must be installed in each power supply bay. [Figure 1-3](#) shows a Cisco 7206 with an installed power supply filler plate.

[Table 1-1](#) lists the AC-input and DC-input power supply system power specifications, including input voltage and operating frequency ranges.

Note

Each AC-input power supply operating at 120 VAC requires a minimum of 5A service. We recommend powering the Cisco 7206 from a 15A receptacle at the power source.

**Note**

Each DC-input power supply operating at -48 VDC in North America requires a minimum of 13A service. Each DC-input power supply operating at -60 VDC in the European Union requires a minimum of 8A service.

This product relies on the building's installation for short-circuit (overcurrent) protection. Ensure that a listed and certified fuse or circuit breaker, 20A minimum 60 VDC, is used on all current-carrying conductors.

The power OK LED goes off and the power supply shuts itself down when the internal DC voltages exceed allowable tolerances or the internal temperature of the power supply exceeds allowable tolerances. The power supply remains in a shutdown state until it is disconnected and reconnected to the source power, and then restarted with the power switch. The power switch turns the power supply on and starts the system. For a description of power supply shutdown conditions and thresholds, refer to the [“Environmental Monitoring and Reporting Functions”](#) section on page 1-31.

Chassis

The Cisco 7206 chassis, shown in [Figure 1-17](#), has six slots for the port adapters, one slot for the I/O controller, and one bay for the subchassis. To replace the chassis, you must remove all of the internal components, including the subchassis.

**Note**

To replace the chassis you must remove all of its internal components; therefore, when replacing the chassis, refer to the configuration notes that explain how to remove and replace the internal components. The configuration notes are available on [Cisco.com](#).

Figure 1-17 Cisco 7206 Chassis

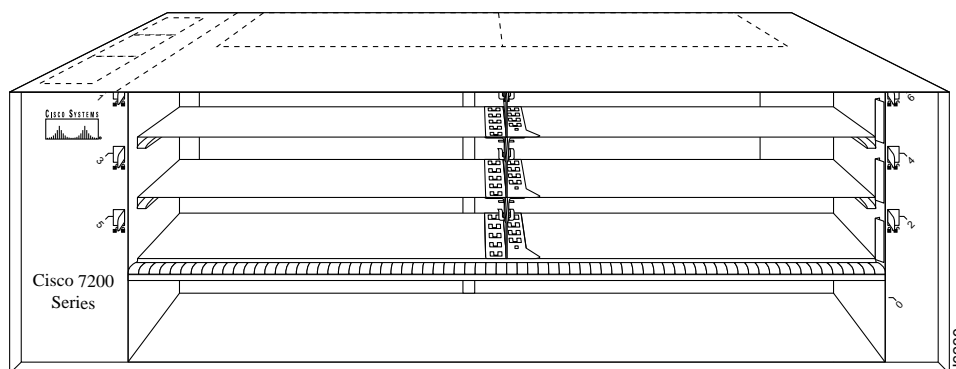

Flash Disks and Flash Memory Cards

The Cisco 7206 supports up to two installed Flash Disks or two Flash memory cards.



Note

To avoid potential problems when inserting spare Flash Disks or Flash memory cards in your Cisco 7206, we recommend that you reformat all of your Flash Disks or Flash memory cards on a Cisco 7206 that is running one of the recommended Cisco IOS software releases listed in Software Advisor. (Flash Disks should be reformatted with a Cisco IOS 12.0 T software image.) The [“Reformatting a Flash Memory Card” section on page 5-12](#) contains instructions that explain how to reformat a Flash memory card.

Flash memory (Flash Disks or Flash memory cards and the Flash SIMM on the I/O controller) allows you to remotely load and store multiple system and boot helper images. You can download a new image over the network and then add the new image to Flash memory or replace existing files. You can also transfer images between Flash Disks or Flash memory cards and the onboard Flash memory. You can then boot the router either manually or automatically from any of the stored images. Flash memory can also function as a TFTP server to allow other routers to boot remotely from stored images or copy them into their own Flash memory.



Note

For procedures that explain the use of the Flash Disk, refer to the *Using the Flash Disk* document that accompanies every Flash Disk shipped from the factory.

For procedures that explain how to replace main, Flash, and ROM monitor memory in Cisco 7200 series routers, refer to the *Memory Replacement Instructions for the Network Processing Engine or Network Services Engine and Input/Output Controller* document that accompanies every memory option (main, Flash, and ROM monitor) that is shipped from the factory as a FRU.

The preceding documents are also available on Cisco.com. Instructions for installing and removing a Flash memory card are also contained in the section [“Installing and Removing a Flash Memory Card” section on page 5-7](#) in [Chapter 5, “Maintaining the Cisco 7206.”](#)

[Table 1-8](#) lists the factory-installed Flash memory card options and their product numbers.

Table 1-8 Flash Memory Card Options

Memory Size	Product Number
20 MB	MEM-I/O-FLC20M ¹

1. This product is also available as a Flash Card upgrade. To order an upgrade, add an equal sign (=) after the product number, for example, MEM-I/O-FLC20M=.

Table 1-9 lists the factory-installed Flash Disk options and their product numbers

Table 1-9 Flash Disk Memory Options

Memory Size	Product Number
40 MB	MEM-I/O-FLD40M ¹
110 MB	MEM-I/O-FLD110M ¹

1. These products are also available as Flash Disk upgrades. To order an upgrade, add an equal sign (=) after the product number, for example, MEM-I/O-FLD110M=.

Rack-Mount and Cable-Management Kit

The rack-mount and cable-management kit for the Cisco 7206 consists of rack-mount and cable-management brackets that are designed for mounting your router in 19-inch, four-post or telco-type equipment racks and for relieving strain on port adapter interface cables that are installed on port adapters in the router. The kit is shipped with each Cisco 7206 and is also available as a single FRU.

For detailed instructions about how to install the rack-mount and cable-management brackets on your Cisco 7206, refer to [Chapter 3, “Installing the Cisco 7206,”](#) the [“Rack-Mounting the Cisco 7206”](#) section on page 3-2 and the [“General Tabletop or Workbench Installation”](#) section on page 3-9.

Functional Overview

This section provides a functional overview of the Cisco 7206. It describes the numbering and addressing scheme of the port adapters for the router, the environmental monitoring and reporting functions, and online insertion and removal (OIR). These descriptions will help you become familiar with the capabilities of the Cisco 7206 router.

Port Adapter Slot and Logical Interface Numbering

In the Cisco 7206, the port adapter slot number is the chassis slot in which a port adapter or service adapter is installed, whereas the logical interface number is the physical location of the interface port on a port adapter (service adapters do not have interface ports). Port adapter slots are numbered from 1 through 6; port adapter slot 0 is reserved for the optional Fast Ethernet port on the I/O controller—if present. (Refer to [Figure 1-2](#) for the numbering scheme of the port adapter slots.) The number of logical interfaces depends on the type of port adapter.



Note

For information about port adapter slot numbering and logical interface numbering for a Cisco 7206 as router shelf in a Cisco AS5800 Universal Access Server, refer to the Cisco AS5800 Universal Access Server documentation listed in the Preface, [“Related Documentation”](#) section on page xiv.

The Media Access Control (MAC) or hardware address is a standardized data link layer address that is required for certain network interface types. These addresses are not used by other devices in the network; they are specific and unique to each port. The Cisco 7206 uses a specific method to assign and control the MAC addresses of its port adapters. For a description of the MAC address, refer to the [“MAC Address”](#) section on page 1-30” section later in this chapter.

Port adapter slots maintain the same slot number regardless of whether other port adapters or service adapters are installed or removed. However, when you move a port adapter to a different slot, the port adapter slot number changes to reflect the new slot number.

You can identify port adapter slots by using software commands to display information about a specific port adapter or service adapter or for all port adapters and service adapters in the Cisco 7206. To display information about all port adapter slots, use the **show interfaces** command. To display information about a specific port adapter slot, use the **show interfaces** command with the port adapter type and slot number in the format **show interfaces port-adapter-type slot-number/port-number**. If you abbreviate the command (**sh int**) and do not specify port adapter type and slot number (or arguments), the system interprets the command as **show interfaces** and displays the status of all port adapters and ports.

Following is an example of how the **show interfaces** command, used without arguments, displays status information (including the physical port adapter number) for each port adapter in a Cisco 7206.

In the following example, most of the status information for each interface is omitted.

```
Router# show interfaces

FastEthernet0/0 is administratively up, line protocol is up
  Hardware is DEC21140, address is 0000.0000.0000 (bia 0000.0000.0000)
  Internet address is 10.1.1.3
  MTU 1500 bytes, BW 100000 Kbit, DLY 100 usec, rely 255/255, load 1/255

(display text omitted)

Fddi1/0 is administratively down, line protocol is down
  Hardware is MIF68840_MM, address is 0000.0000.0000 (bia 0000.0000.0000)
  Internet address is 10.1.1.0
  MTU 4470 bytes, BW 100000 Kbit, DLY 100 usec, rely 255/255, load 1/255

  (display text omitted)

Ethernet2/0 is administratively up, line protocol is up
  Hardware is AmdP2, address is 0000.0000.0000 (bia 0000.0000.0000)
  Internet address is 10.1.1.7
  MTU 1500 bytes, BW 100000 Kbit, DLY 1000 usec, rely 255/255, load 1/255

(display text omitted)
```

You can also use arguments such as the interface type (Ethernet, Token Ring, FDDI, and so forth) and the port address (*slot-number/port-number*) to display information about a specific interface only.

The following example shows the display for the first port on the Token Ring port adapter in port adapter slot 3:

```
Router# show interfaces tokenring 3/0

TokenRing3/0 is administratively down, line protocol is down
  Hardware is IBM2692, address is 0000.0000.0000 (bia 0000.0000.0000)
  Internet address is 10.1.1.8
  MTU 4464 bytes, BW 1600 Kbit, DLY 630 usec, rely 255/255, load 1/255
  Encapsulation SNAP, loopback not set, keepalive set (10 sec)
  ARP type: SNAP, ARP Timeout 04:00:00
  Ring speed: 16 Mbps

  (display text omitted)
```

For complete descriptions and instructions of the commands used to configure your Cisco 7206, refer to the *Configuration Fundamentals Configuration Guide* and *Configuration Fundamentals Command Reference* publications, which are available on Cisco.com.

MAC Address

All LAN interfaces (ports) require unique MAC addresses, also known as *hardware* addresses. Typically, the MAC address of an interface is stored on a memory component that resides directly on the interface circuitry; however, the OIR feature requires a different method. For a description of OIR, refer to the “[Online Insertion and Removal](#)” section later in this chapter.

The OIR feature allows you to remove a port adapter or service adapter and replace it with another identically configured one. If the new port adapter or service adapter matches the adapter you removed, the system immediately brings it online. In order to enable OIR, an address allocator with a unique MAC address is stored in an EEPROM on the router midplane. Each address is reserved for a specific port and slot in the router regardless of whether a port adapter or service adapter resides in that slot. The MAC addresses are assigned to the slots in sequence. The first address is assigned to slot 0, and the last address is assigned to slot 6. This address scheme allows you to remove port adapters and service adapters and insert them into other routers without causing the MAC addresses to move around the network or be assigned to multiple devices.

Note that if the MAC addresses were stored on each port adapter or service adapter, OIR would not function because you could never replace one adapter with an identical one; the MAC addresses would always be different. Also, each time a port adapter or service adapter was replaced, other devices on the network would have to update their data structures with the new address. If the other devices did not update quickly enough, the same MAC address could appear in more than one device at the same time.

**Note**

Storing the MAC addresses for every slot in one central location means the addresses stay with the memory device on which they are stored.

Online Insertion and Removal

All port adapters and service adapters in the Cisco 7206 support online insertion and removal (OIR). This function allows you to install and replace port adapters and service adapters while the router is operating; you do not need to notify the software or shut down the system power. This provides a method that is seamless to end users on the network, maintains all routing information, and preserves sessions.

The following is a functional description of OIR for background information only; for specific procedures for installing and replacing a port adapter or service adapter in a Cisco 7206 router, refer to the configuration note that ships with each port adapter or service adapter.

**Caution**

The network processing engine and the I/O controller are required system components that cannot be removed if the router is operating. Removing the network processing engine or the I/O controller while the router is operating will cause the router to shut down or crash, and might damage or destroy memory files.

Each port adapter and service adapter has a bus connector that connects it to the router midplane. Each midplane connector has a set of tiered pins in three lengths that send specific signals to the system as they make contact with the port or service adapter. The system assesses the signals it receives and the order in which it receives them to determine if a port adapter or service adapter is being removed or inserted into the midplane. From these signals, the system determines whether to reinitialize a new interface or shut down a removed interface. For example, when you insert a port or service adapter, the longest pins make contact with the port or service adapter first, and the shortest pins make contact last. The system recognizes the signals and the sequence in which it receives them.

When you remove or insert a port adapter or service adapter in a Cisco 7206 router, the midplane pins send signals to notify the system, which then performs as follows:

1. Rapidly scans the midplane for configuration changes.
2. Initializes all newly inserted port adapters and service adapters, noting any removed port adapter interfaces and placing them in the administratively shutdown state.
3. Brings all previously configured interfaces on the port adapter back to the state they were in when they were removed (service adapters do not have interfaces). Any newly inserted interfaces are put in the administratively shutdown state, as if they were present (but not configured) at boot time. If a similar port adapter type is reinserted into a slot, its ports are configured and brought online up to the port count of the original port adapter. (A service adapter has no configurable ports.)

Environmental Monitoring and Reporting Functions

Environmental monitoring and reporting functions are controlled by the network processing engine and allow you to maintain normal system operation by identifying and resolving adverse conditions prior to loss of operation. The environmental monitoring functions constantly monitor the internal chassis air temperature and DC supply voltages and currents. Each power supply monitors its own voltage and temperature and shuts itself down if it detects a critical condition within the power supply. If conditions reach shutdown thresholds, the system shuts down to avoid equipment damage from excessive heat. The reporting functions periodically log the values of measured parameters so that you can retrieve them for analysis later, and the reporting functions display warnings on the console if any of the monitored parameters exceed defined thresholds.

Environmental Monitoring

The environmental monitoring functions use four sensors, two on the network processing engine and two on the I/O controller, to monitor the temperature of the cooling air as it moves through the chassis.

[Table 1-10](#) lists the temperature thresholds for each network processing engine type.

If the air temperature exceeds a defined threshold, the system controller displays warning messages on the console terminal and, if the temperature exceeds the shutdown threshold, the system controller shuts down the system. The system stores the present parameter measurements for both temperature and DC voltage in NVRAM, so that you can retrieve them later as a report of the last shutdown parameters.

The power supplies monitor internal power supply temperature and voltages. A power supply is either within tolerance (normal) or out of tolerance (critical). If an internal power supply temperature or voltage reaches a critical level, the power supply shuts down without any interaction with the system processor.

Table 1-10 Typical Processor-Monitored Temperature Thresholds

Parameter	High Warning	High Critical	Shutdown
NPE-100 or NPE-200			
Chassis inlet	104°F (40°C)	122°F (50°C)	–
Chassis outlet 1	109°F (43°C)	127°F (53°C)	136°F (58°C)
Chassis outlet 2	167°F (75°C)	167°F (75°C)	–
Chassis outlet 3	122°F (50°C)	140°F (60°C)	149°F (65°C)

Table 1-10 Typical Processor-Monitored Temperature Thresholds (continued)

Parameter	High Warning	High Critical	Shutdown
NPE-150			
Chassis inlet	104°F (40°C)	122°F (50°C)	–
Chassis outlet 1	109°F (43°C)	127°F (53°C)	136°F (58°C)
Chassis outlet 2	167°F (75°C)	167°F (75°C)	–
Chassis outlet 3	131°F (55°C)	149°F (65°C)	158°F (70°C)
NPE-175 and NPE-225			
Chassis inlet	104°F (40°C)	122°F (50°C)	–
Chassis outlet 1	109°F (43°C)	127°F (53°C)	136°F (58°C)
Chassis outlet 2	109°F (43°C)	127°F (53°C)	–
Chassis outlet 3	131°F (55°C)	149°F (65°C)	158°F (70°C)

Table 1-11 lists the DC power thresholds for the normal, warning, and critical (power supply-monitored) levels.

- Normal—All monitored parameters are within normal tolerances.
- Warning—The system has exceeded a specified threshold. The system continues to operate, but operator action is recommended to bring the system back to a normal state.
- Critical—An out-of-tolerance temperature or voltage condition exists. The system continues to operate; however, the system is approaching shutdown. Immediate operator action is required.
- Shutdown—The processor has detected a temperature condition that could result in physical damage to system components and has disabled DC power to all internal components. This condition requires immediate operator action. All DC power remains disabled until you toggle the power switch. Before any shutdown, the system logs the status of monitored parameters in NVRAM so you can retrieve it later to help determine the cause of the problem.
- Power supply shutdown—The power supply detected an internal out-of-tolerance overvoltage, overcurrent, or temperature condition and shut itself down. All DC power will remain disabled until you toggle the power switch.

Table 1-11 Typical Power Supply-Monitored DC-Voltage Thresholds

Parameter	Low Critical	Low Warning	High Warning	High Critical
+3.45V	+3.26V	+3.34V	+3.55V	+3.63V
+5.15V	+4.86V	+4.99V	+5.31V	+5.43V
+12.15V	+11.39V	+11.67	+12.62V	+12.91V
–11.95V	–9.52V	–10.73	–13.16V	–14.38V

**Note**

A low warning or high warning message does not mean that the router is at risk of malfunctioning or being damaged.

The low warning and high warning ranges in [Table 1-11](#) are informational and if a low warning or high warning message appears, the warning message does *not* signify that an error or hazard is occurring. A high warning message sometimes appears in a lightly loaded chassis, especially if the router is running without port adapters or with dual power supplies. Adding current load to the router may remove the warning; this can easily be achieved by installing one or more port adapters.

Below are sample high warning messages from chassis with 3V and 5V power supplies:

```
Router(boot)#
00:00:44:%ENVM-4-ENVWARN:+3.45 V measured at +3.57
```

```
Router(boot)#
00:04:49:%ENVM-4-ENVWARN:+5.15 V measured at +5.33
```



Note

Low critical or high critical warning messages should be addressed immediately through the normal field support procedures.

Below are sample high critical messages from chassis with 3V and 5V power supplies:

```
Router(boot)#
00:02:47:%ENVM-2-ENVCRIT:+3.45 V measured at +3.66
```

```
Router(boot)#
00:06:51:%ENVM-2-ENVCRIT:+5.15 V measured at +5.47
```

Reporting Functions

The Cisco 7206 displays warning messages on the console if chassis interface-monitored parameters exceed a defined threshold. You can also retrieve and display environmental status reports with the **show environment**, **show environment all**, **show environment last**, and **show environment table** commands. Parameters are measured and reporting functions are updated every 60 seconds. A brief description of each of these commands follows.



Caution

To prevent overheating the chassis, ensure that your system is drawing cool inlet air. Overtemperature conditions can occur if the system is drawing in the exhaust air of other equipment. Ensure adequate clearance around the sides of the chassis so that cooling air can flow through the chassis interior unimpeded and exhaust air exits the chassis and is not drawn into the inlet vent of another device.

The **show environment** command display reports the current environmental status of the system. The report displays parameters that are out of the normal values. No parameters are displayed if the system status is normal. The example that follows shows the display for a system in which all monitored parameters are within normal range:

```
Router# show environment

All measured values are normal
```

If the environmental status is *not* normal, the system reports the worst-case status level. Following is a sample overvoltage warning:

```
Router# show environment

Warning: +3.45 V measured at +3.83 V
```

The **show environment last** command retrieves and displays the NVRAM log, which shows the reason for the last system shutdown (if the shutdown was related to voltage or temperature) and the environmental status at that time. Air temperature is measured and displayed, and the DC voltage supplied by the power supply is also displayed.

Following is sample output of the **show environment last** command:

```
Router# show environment last

Temperature readings:
  chassis inlet previously measured at 27C/80F
  chassis outlet 1 previously measured at 31C/87F
  chassis outlet 2 previously measured at 37C/98F
  chassis outlet 3 previously measured at 45C/113F

Voltage readings:
  +3.45 V previously measured at +3.51 V
  +5.2 V previously measured at +5.19 V
  +12.2 V previously measured at +12.42 V
  -12.2 V previously measured at -12.14 V

Reason for last shutdown:
  power supply
```

The **show environment table** command displays the temperature and voltage thresholds for each temperature sensor and for each monitored status level, which are related to those thresholds listed in [Table 1-10](#) and [Table 1-11](#). The display also lists the shutdown threshold for the system.

Following is sample output of the **show environment table** command for a Cisco 7206 that has an installed NPE-150:

```
Router# show environment table

Sample Point      LowCritical      LowWarning      HighWarning      HighCritical
chassis inlet          40C/104F        50C/122F
chassis outlet 1      43C/109F        53C/127F
chassis outlet 2      75C/167F        75C/167F
chassis outlet 3      55C/131F        65C/149F
+3.45 V              +3.26           +3.34           +3.55            +3.63
+5.15 V              +4.86           +4.99           +5.31            +5.43
+12.15 V             +11.39          +11.67          +12.62           +12.91
-11.95 V             -9.52           -10.73          -13.16           -14.38
System shutdown for chassis outlet 1 58C/136F
System shutdown for chassis outlet 3 70C/158F
```

Following is sample output of the **show environment table** command for a Cisco 7206 that has an installed NPE-100 or NPE-200:

```
Router# show environment table

Sample Point      LowCritical      LowWarning      HighWarning      HighCritical
chassis inlet          40C/104F        50C/122F
chassis outlet 1      43C/109F        53C/127F
chassis outlet 2      75C/167F        75C/167F
chassis outlet 3      50C/122F        60C/140F
+3.45 V              +3.26           +3.34           +3.55            +3.63
+5.15 V              +4.86           +4.99           +5.31            +5.43
+12.15 V             +11.39          +11.67          +12.62           +12.91
-11.95 V             -9.52           -10.73          -13.16           -14.38
System shutdown for chassis outlet 1 58C/136F
System shutdown for chassis outlet 3 65C/149F
```

**Note**

Temperature ranges and values are subject to change.

The **show environment all** command displays an extended report that includes temperature readings and voltage readings. The **show environment all** command also displays a report showing which power supply slots are occupied and which are empty.

Following is sample output of the **show environment all** command:

```
Router# show environment all
```

```
Power Supplies:
```

```
Power supply 1 is Zytek AC Power Supply. Unit is on.  
Power supply 2 is Zytek AC Power Supply. Unit is on.
```

```
Temperature readings:
```

```
chassis inlet      measured at 47C/116F:Temperature in Warning range!  
chassis outlet 1 measured at 49C/120F:Temperature in Warning range!  
chassis outlet 2 measured at 55C/131F  
chassis outlet 3 measured at 58C/136F:Temperature in Warning range!
```

```
Voltage readings:
```

```
+3.45 V measured at +3.51 V  
+5.2 V  measured at +5.19 V  
+12.2 V measured at +12.42 V  
-12.2 V measured at -12.14 V
```

Fan Failures

When the system power is on, all three fans should be operational. The system continues to operate if a fan fails; however, if the air temperature exceeds a defined threshold, the system controller displays warning messages on the console terminal and, if the temperature exceeds the shutdown threshold, it shuts down the system.

If the system does shut down because the temperature exceeded the shutdown threshold, the system displays the following message on the console screen and in the environment display when the system restarts:

```
Queued messages:
```

```
%ENVM-1-SHUTDOWN: Environmental Monitor initiated shutdown
```

For complete descriptions and instructions of the environmental monitor commands refer to the *Configuration Fundamentals Configuration Guide* and *Configuration Fundamentals Command Reference* publications.



Preparing for Installation

Before installing your Cisco 7206 you should consider the power and cabling requirements that must be in place at your installation site, the equipment you will need to install the router, and the environmental conditions your installation site must meet to maintain normal operation. This chapter guides you through the process of preparing for your router installation.

This chapter describes the equipment and site requirements for installing the Cisco 7206. The chapter contains the following sections:

- [Electrical Equipment Guidelines, page 2-1](#)
- [Site Requirements, page 2-2](#)
- [Tools for Installation, page 2-8](#)
- [Initial Configuration Information, page 2-9](#)
- [Cisco 7206 Installation Checklist, page 2-10](#)
- [Checking the Shipping Container Contents, page 2-11](#)
- [Site Log, page 2-12](#)



Note

For equipment and site requirements when preparing to install a Cisco 7206 as a router shelf in a Cisco AS5800 Universal Access Server, refer to the Cisco AS5800 Universal Access Server documentation listed in the Preface, “[Related Documentation](#)” section on page xiv.



Warning

Before your install, operate, or service the system, read the *Site Preparation and Safety Guide*. This guide contains important safety information you should know before working with the system.

Electrical Equipment Guidelines

The port adapters and power supplies are designed to be removed and replaced while the system is operating without presenting an electrical hazard or damage to the system. However, you *must* power down the system before removing or replacing the I/O controller and network processing engine (NPE).



Caution

Always tighten the captive installation screws on the network processing engine or network services engine and I/O controller. These screws prevent accidental removal, provide proper grounding for the system, and help ensure that the bus connectors are properly seated in the midplane.

Preventing Electrostatic Discharge Damage

Electrostatic discharge (ESD) damage, which occurs when electronic cards or components are improperly handled, can result in complete or intermittent system failures. The network processing engine, I/O controller, and each port adapter consists of a printed circuit board that is fixed in a metal carrier. Electromagnetic interference (EMI) shielding, connectors, and a handle are integral components of the carrier. Although the carrier helps protect the boards, use an antistatic strap whenever handling the network processing engine, I/O controller, and port adapters. Handle the carriers by the handle and the carrier edges only; never touch the boards or connector pins.

**Caution**

Always tighten the captive installation screws on the network processing engine and I/O controller. (See [Figure 1-4](#) and [Figure 1-9](#).) These screws prevent accidental removal, provide proper grounding for the system, and help ensure that the bus connectors are properly seated in the midplane.

Site Requirements

Use this section for obtaining information about site requirements.

AC and DC Power

The AC-input power supply uses a power factor corrector that allows the Cisco 7206 to operate on input voltage and frequency within the ranges of 100 to 240 VAC and 50 to 60 Hz.

**Note**

We recommend attaching dual power supplies to independent power sources for full redundancy. We also recommend an uninterruptible power source to protect against power failures at your site.

The DC-input power supply allows the Cisco 7206 router to operate at –48 VDC nominal in North America and –60 VDC in Europe.

Refer to [Table 1-1](#) in [Chapter 1, “Product Overview”](#) for system power specifications, including input voltage and operating frequency ranges.

Plant Wiring Guidelines

Following are guidelines for setting up the plant wiring and cabling at your site. When planning the location of the new system, consider the distance limitations for signaling, EMI, and connector compatibility, as described in the following sections.

Interference Considerations

When wires are run for any significant distance in an electromagnetic field, interference can occur between the field and the signals on the wires. This fact has two implications for the construction of plant wiring:

- Bad wiring practice can result in radio interference emanating from the plant wiring.

- Strong EMI, especially when it is caused by lightning or radio transmitters, can destroy the signal drivers and receivers in the Cisco 7206, and can even create an electrical hazard by conducting power surges through lines and into equipment. (Review the safety warnings in the *Site Preparation and Safety Guide*.)

**Note**

To predict and remedy strong EMI, you may also need to consult experts in radio frequency interference (RFI).

If you use twisted-pair cable in your plant wiring with a good distribution of grounding conductors, the plant wiring is unlikely to emit radio interference. If you exceed the recommended distances, use a high-quality twisted-pair cable with one ground conductor for each data signal when applicable.

If wires exceed recommended distances, or if wires pass between buildings, give special consideration to the effect of a lightning strike in your vicinity. The electromagnetic pulse caused by lightning or other high-energy phenomena can easily load enough energy into unshielded conductors to destroy electronic devices. If you have had problems of this sort in the past, you may want to consult experts in electrical surge suppression and shielding.

Distance Limitations and Interface Specifications

The size of your networks and the distances between connections depend on the type of signal, the signal speed, and the transmission media (the type of cabling used to transmit the signals). For example, standard coaxial cable has a greater channel capacity than twisted-pair cabling. The distance and rate limits in the following descriptions are the IEEE-recommended maximum speeds and distances for signaling; however, you can usually get good results at speeds and distances far greater than these. For example, the recommended maximum rate for V.35 is 2 Mbps, but it is commonly used at 4 Mbps without any problems. If you understand the electrical problems that might arise and can compensate for them, you should get good results with rates and distances greater than those shown here; however, do so at your own risk.

**Note**

We recommend that you do not exceed specified transmission rate and distance limits.

When preparing your site for network connections to the Cisco 7206, you must consider a number of factors related to each type of interface:

- The type of cabling required for each type (fiber, thick or thin coaxial, shielded twisted-pair, or unshielded twisted-pair cabling)
- Distance limitations for each signal type
- The specific cables you need to connect each interface
- Any additional interface equipment you need, such as transceivers, hubs, switches, modems, channel service units (CSUs), or data service units (DSUs)
- Cable pinouts if you plan to build your cables

The information listed above is contained in the documentation that is shipped with each port adapter. For example, if you need ATM distance limitations and pinouts, refer to the configuration note *PA-A3 Enhanced ATM Port Adapter Installation and Configuration*. This configuration note accompanies each PA-A3 enhanced ATM port adapter that is shipped from the factory as an installed item in a Cisco 7206 and as a FRU.

Before installing the Cisco 7206, have all additional external equipment and cables on hand. For ordering information, contact a customer service representative.

Equipment Racks

The rack-mounting hardware included with the Cisco 7206 is suitable for most 19-inch equipment racks and telco-type racks. To easily access FRUs while the router is installed in a rack, make certain you have access to the front and rear of the router.

Before using a particular rack, check for obstructions (such as a power strip) that could impair rack-mount installation. If a power strip does impair a rear rack-mount installation, remove the power strip before installing the Cisco 7206 in the rack, and then replace it after the chassis is installed. As an alternative, you can mount the Cisco 7206 on an equipment shelf provided that the rack dimensions allow you to secure the router to the shelf, and the overall configuration permits safe installation and access. However, we recommend rack-mounting the Cisco 7206. [Figure 2-1](#) shows the Cisco 7206 footprint and outer dimensions.

To use the rack-mounting hardware provided with the Cisco 7206, consider the following guidelines:

- To mount the router between two posts or rails using the brackets, the inner clearance (the width between the *inner* sides of the two posts or rails) must be at least 17 inches (43.18 cm).
- The height of the chassis is 5.25 inches (13.34 cm).
- When mounting the router in either four-post or telco-type racks, be sure to use all the screws and the brackets provided to secure the chassis to the rack posts.

Figure 2-1 Cisco 7206 Footprint and Outer Dimensions

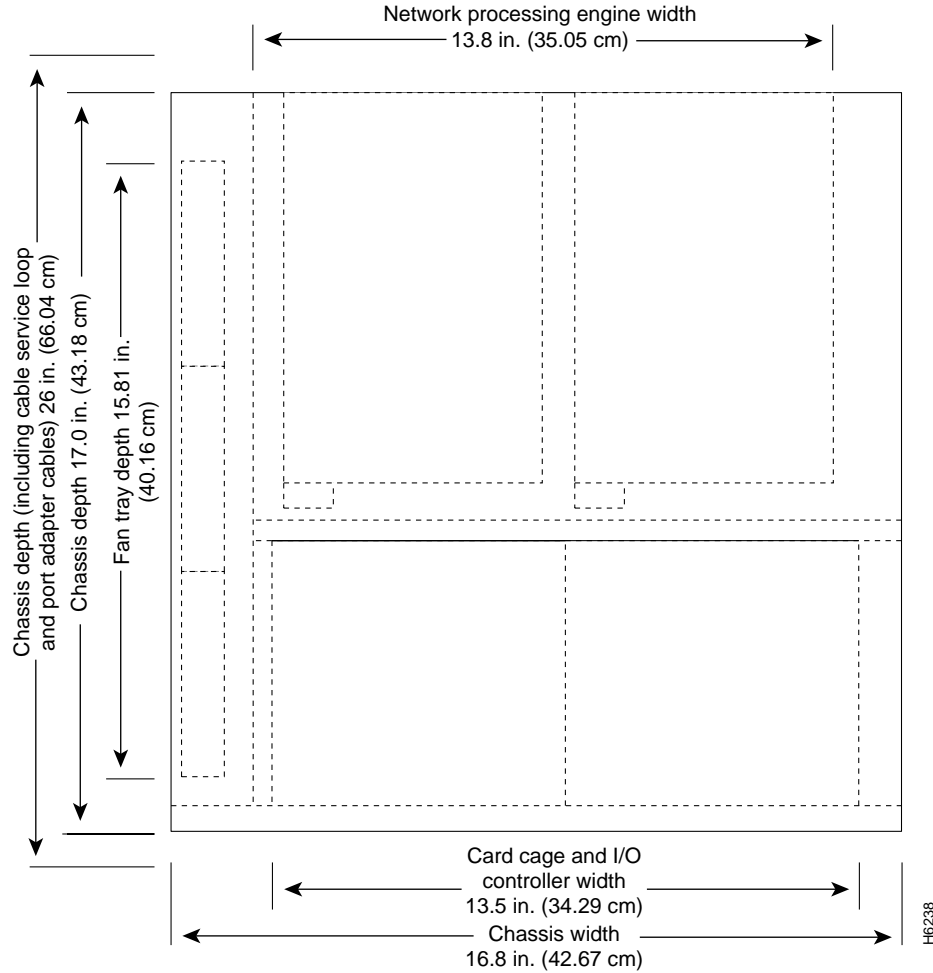

When planning your rack installation, consider the following guidelines:

- Install the Cisco 7206 in an open rack whenever possible. If installation in an enclosed rack is unavoidable, ensure that the rack has adequate ventilation.



Note To prevent chassis overheating, never install the Cisco 7206 in an enclosed rack or room that is not properly ventilated or air conditioned.

- If you plan to use an equipment shelf, ensure that the shelf is constructed to support the weight and dimensions of the chassis. [Figure 2-1](#) shows the chassis footprint, which you will need if you are designing a customized shelf. We recommend that you use the rack-mount kit designed for the Cisco 7206.
- Allow sufficient clearance around the rack for maintenance. If the rack is mobile, you can push it back near a wall or cabinet for normal operation and pull it out for maintenance (installing or moving port adapters, connecting cables, or replacing or upgrading components). Otherwise, allow 19 inches (48.3 cm) of clearance to remove Cisco 7206 FRUs.

- If you are planning to install the cable-management brackets on a Cisco 7206 that you are rack-mounting from the front, you *must* install the cable-management brackets and the rack-mount brackets *before* you install the chassis in the rack.
- Provide an adequate chassis ground (earth) connection for your router chassis.



Note We strongly recommend that you provide a chassis ground connection. Refer to [Chapter 3, “Installing the Cisco 7206,”](#) the “[Providing a Chassis Ground Connection for the Router Chassis](#)” section on page 3-12 for instructions.

To properly install the Cisco 7206 chassis in a rack, refer to the instructions in [Chapter 3, “Installing the Cisco 7206.”](#)

Site Environment

[Table 2-1](#) lists the operating and nonoperating environmental site requirements. The ranges listed are those within which the Cisco 7206 will continue to operate; however, a measurement that is approaching the minimum or maximum of a range indicates a potential problem. You can maintain normal operation by anticipating and correcting environmental anomalies before they approach a maximum operating range.

Table 2-1 Specifications for Operating and Nonoperating Environments

Specification	Minimum	Maximum
Temperature, ambient operating	32°F (0°C)	104°F (40°C)
Temperature, ambient nonoperating and storage	–4°F (–20°C)	149°F (65°C)
Humidity, ambient (noncondensing) operating	10%	90%
Humidity, ambient (noncondensing) nonoperating and storage	5%	95%
Altitude, operating and nonoperating	Sea level	10,000 ft. (3050 m)
Vibration, operating	5–200 Hz, 0.5 g (1 octet/min.)	–
Vibration, nonoperating	5–200 Hz, 1 g (1 octet/min.) 200–500 Hz, 2 g (1 octet/min.)	–

Preventive Site Configuration: Maintaining Normal Operation

Planning a proper location for the Cisco 7206 and the layout of your equipment rack or wiring closet are essential for successful system operation. Equipment placed too close together or inadequately ventilated can cause system overtemperature conditions. In addition, chassis panels made inaccessible by poor equipment placement can make system maintenance difficult. Following are precautions that can help avoid problems during installation and ongoing operation.

When you plan the location and layout of your equipment rack or wiring closet, you need to consider how air flows through your router. The Cisco 7206 draws cooling air in through the intake vent on the right side of the chassis (when you view the router from the front), and moves the air across the internal components and out the exhaust vent on the left side of the chassis.

Temperature sensors on the network processing engine and I/O controller monitor the internal air temperature and send warning messages when the internal air temperature approaches a specified threshold. If the internal temperature exceeds the specified threshold, the system environmental monitor shuts down all internal power to prevent equipment damage from excessive heat. (See [Chapter 1, “Product Overview,”](#) the [“Environmental Monitoring and Reporting Functions”](#) section on page 1-31 for temperature threshold information.)

[Figure 2-2](#) shows the airflow through the router.

Figure 2-2 Internal Airflow—Top View

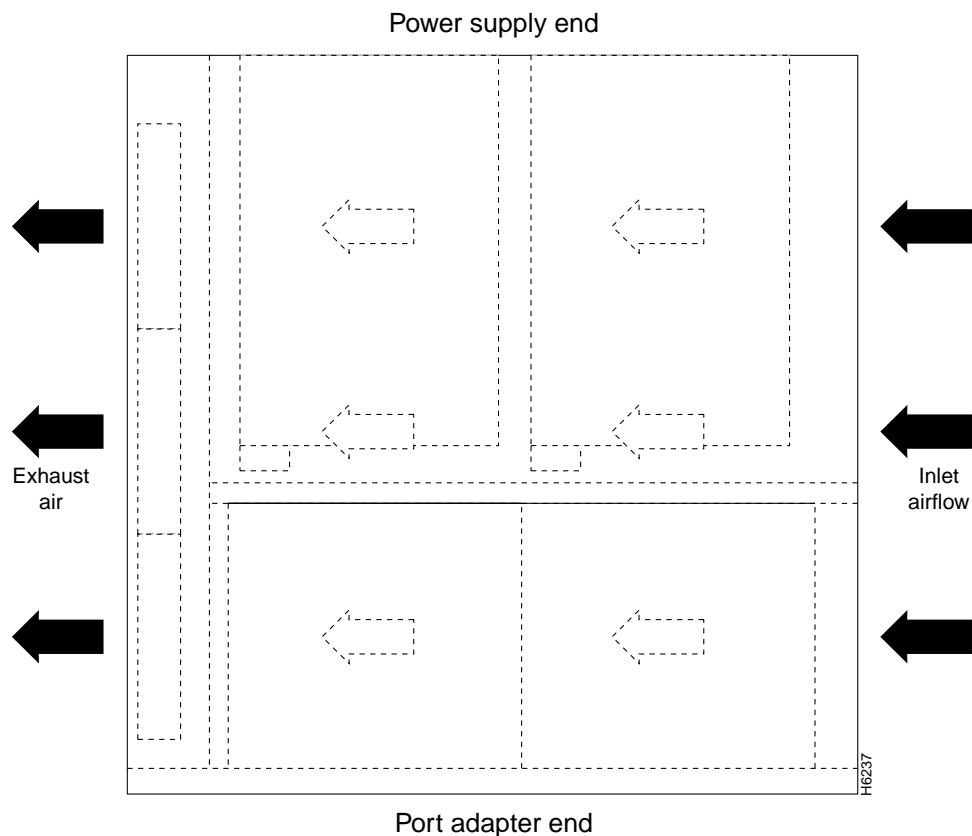

The left and right sides of the chassis must remain unobstructed to ensure adequate airflow and prevent overheating inside the chassis; we recommend at least 3 in. (7.62 cm) of clearance.

General Precautions

Follow these general precautions when planning your equipment locations and connections:

- Use the **show environment** command regularly to check the internal system status. The environmental monitor continually checks the interior chassis environment; it provides warnings for high temperature and maximum and minimum voltages and creates reports on any occurrences. If warning messages are displayed, take immediate action to identify the cause and correct the problem.
- We recommend keeping the Cisco 7206 off the floor and out of any area that tends to collect dust.
- Follow ESD prevention procedures to avoid damage to equipment. Damage from static discharge can cause immediate or intermittent equipment failure.
- Ensure that the network processing engine, I/O controller, port adapters, any blank port adapters, power supplies, and any power supply filler plates are in place and secure. The fans direct cooling air throughout the chassis interior; a loose component or empty slot can redirect the airflow away from active components.

Power Considerations

Follow these precautions and recommendations when planning power connections to the Cisco 7206:

- Check the power at your site before installation and periodically after installation to ensure that you are receiving clean power. Install a power conditioner if necessary.
- Install proper grounding to avoid damage from lightning and power surges.



Note

The Cisco 7206 installation must comply with all applicable codes and is approved for use with copper conductors only. The ground bond fastening hardware should be of compatible material and preclude loosening, deterioration, and electrochemical corrosion of hardware and joined material. Attachment of the chassis ground to a central office or other interior ground system should be made with a 6-AWG, copper ground conductor at a minimum.

The Cisco 7206 chassis employs two threaded M5 chassis grounding receptacles, located on the rear of the chassis, which are intended to be bonded directly to the central offices or other interior ground system. The chassis ground requires M5 screws and locking hardware, which are not included. (For instructions on how to properly ground the chassis, refer to [Chapter 3, “Installing the Cisco 7206,”](#) the [“Providing a Chassis Ground Connection for the Router Chassis”](#) section on page 3-12.)

Tools for Installation

Your Cisco 7206 chassis is fully assembled at the factory; no assembly is required. However, you will need the following tools and equipment to install the chassis and the rack-mount and cable-management kit:

- Number 2 Phillips screwdriver
- A 3/16-inch flat-blade screwdriver
- Tape measure (optional)
- Level (optional)

The rack-mount and cable-management kit includes the following parts:

- Two rack-mount brackets for mounting the chassis in the rack
- Four M4 x 8-mm Phillips flathead screws to secure the rack-mount brackets to the chassis
- Six 10-32 x 3/8-inch slotted binderhead screws to secure the rack-mount brackets to the rack rails
- Two cable-management brackets to relieve the strain on installed port adapter interface cables
- Four M4 x 8-mm Phillips flathead screws to secure the cable-management brackets to the chassis or the rack-mount brackets

In addition, you might need the following external equipment:

- Data service unit (DSU) to connect each serial port to an external network
- One serial port adapter cable for each serial port to connect the port with the remote device or network.
- T1 channel service unit/data service unit (CSU/DSU) that converts the High-Level Data Link Control (HDLC) synchronous serial data stream into a T1 data stream with the correct framing and ones density to connect a serial port to a T1 network. (Some telephone systems require a minimum number of 1 bits per time unit in a data stream, called *ones density*.) Several T1 CSU/DSU devices are available as additional equipment, and most provide either a V.35, EIA/TIA-449, or EIA-530 electrical interface.
- Ethernet transceiver
- Token Ring multistation access unit (MSAU)
- Optical bypass switch or concentrator for multimode Fiber Distributed Data Interface (FDDI) connections

Initial Configuration Information

After you install the chassis and verify that all the hardware is operating properly, you must configure the system and individual interfaces before you can connect your system to external networks. You can use the setup command facility or standard configuration commands to enter the configuration information.

Before you begin, you should be prepared with global (system-wide) parameters such as host names, passwords, and routing protocols, and configuration information for each interface such as addresses, rates or speeds of operation, routing protocol specifics, and so on.

Following is some of the information you are likely to need, depending on your configuration:

- Host name for the router
- Passwords to prevent unauthorized privileged-level access to the EXEC command interpreter and for individual virtual terminal lines
- Protocols you plan to route.
- Bridging configuration (if you plan to use bridging and, if so, on which interfaces)
- Internet Protocol (IP) addresses and subnet masks if you are routing IP
- Zone names, network numbers, or node numbers for the new interfaces if required
- Operating speeds for specific interfaces—for example, Token Ring interfaces operate at either 4 or 16 Mbps, and serial interfaces operate at speeds of up to 2 Mbps. The speed of an interface often depends on the speed of the remote device to which it is attached.

For complete configuration instructions, refer to the *Configuration Fundamentals Configuration Guide* and the *Configuration Fundamentals Command Reference*, which are available on Cisco.com.

Cisco 7206 Installation Checklist

To assist you with your installation and to provide a historical record of what was done by whom, use the Cisco 7206 Installation Checklist in [Table 2-2](#). Make a copy of this checklist and indicate when each procedure or verification is completed. When the checklist is completed, place it in your site log (described at the end of this chapter) along with the other records for your new router.

Table 2-2 Cisco 7206 Installation Checklist

Task	Verified by	Date
Date router received		
Router and all accessories unpacked		
Types and numbers of interfaces verified		
Safety recommendations and guidelines reviewed		
Installation Checklist copied		
Site log established and background information entered		
Site power voltages verified		
Site environmental specifications verified		
Required passwords, IP addresses, device names, and so on, available		
Required tools available		
Network connection equipment available		
Router mounted in rack (optional)		
Cable-management brackets installed (optional but recommended)		
AC power cable(s) connected to AC source(s) and router; retention clip secured		
DC power cable(s) connected to DC source(s) and router		
Captive installation screws on I/O controller and NPE checked		
Network interface cables and devices connected		
ASCII terminal attached to console port		
Console port set for 9600 baud, 8 data bits, no parity, and 2 stop bits (9600 8N2)		
System power turned on (DC OK LED is on)		
System boot complete (I/O controller enabled LED is on)		
I/O controller, network processing engine, and all port and service adapters operational (enabled LEDs on the adapters and the I/O controller are on)		
Console screen displays correct hardware configuration (displayed after system banner)		
System ready for global and interface-specific configuration		

Checking the Shipping Container Contents

Once you receive your Cisco 7206 router, use the following procedure to check the contents of the shipping container. Use the [Cisco 7206 Installation Checklist](#) in [Table 2-2](#) and the [Cisco 7206 Component List](#) in [Table 2-3](#) to ensure you received all the components you ordered.

**Note**

Do not discard the shipping container. You will need the container if you move or ship the Cisco 7206 in the future.

-
- Step 1** Verify that the following are included in the shipping container (the accessories box might be separate):
- One Cisco 7206 router, fully assembled (except the rack-mount and cable-management kit)
 - One or more accessories boxes (some or all may be shipped separately)
- Step 2** Check the contents of the accessories box against the [Cisco 7206 Component List](#) and the packing slip to verify that you received all listed equipment, which should include the following:
- One modular power cable for each AC-input power supply
 - One rack-mount and cable-management kit (four brackets and 14 mounting screws)
 - Optional equipment that you ordered, such as network interface cables, transceivers, or special connectors
 - Cisco 7206 hardware and software documentation, if ordered

**Note**

We no longer ship the entire router documentation set automatically with each system. You must specifically order the documentation as part of the sales order. If you ordered documentation and did not receive it, we will ship the documents to you within 24 hours. To order documents, contact a customer service representative.

- Step 3** Verify that the port adapters installed in your Cisco 7206 match the port adapter types on the packing list.
- Step 4** Proceed to the “[Site Log](#)” section in this chapter, and then to [Chapter 3, “Installing the Cisco 7206”](#) to begin the installation.
-

Table 2-3 Cisco 7206 Component List

Component	Description	Received
Chassis	Cisco 7206 chassis configured with a network processing engine, I/O controller, up to two AC or DC power supplies, up to six port and service adapters (blank adapters should be installed in empty port adapter slots), and up to two Flash memory cards	
Accessories:	The following accessories might arrive in separate shipping containers:	
<ul style="list-style-type: none"> • Rack-mount and cable-management kit 	Two rack-mount brackets, two cable-management brackets, eight M4 x 8-mm Phillips flathead screws, and six 10-32 x 3/8-inch slotted binderhead screws	
<ul style="list-style-type: none"> • Power cables 	Up to two power cables	
<ul style="list-style-type: none"> • Documentation 	If ordered, router hardware and software documentation ¹	

1. Titles and quantities of documents will vary. You must order the type and quantity of documentation sets when you order the hardware.

Site Log

A site log provides a historical record of all actions relevant to the Cisco 7206 operation and maintenance. Keep your site log in a common place near the chassis where anyone who performs tasks has access to it. Site log entries might include the following:

- Installation progress—Make a copy of the Cisco 7206 Installation Checklist and insert it into the site log. Make entries on this checklist as each procedure is completed.
- Upgrades and removal and replacement procedures—Use the site log as a record of system maintenance and expansion history. Each time a procedure is performed on the system, update the site log to reflect the following:
 - Port and service adapters installed, removed, or replaced
 - I/O controller removed and replaced
 - Network processing engine removed and replaced
 - Subchassis removed and replaced
 - Fan tray removed and replaced
 - Power supply removed or replaced
 - Chassis replaced
 - Configuration changed; port or service adapters moved
 - Software upgraded
 - Corrective maintenance procedures performed
 - Intermittent problems
 - Related comments

Table 2-4 shows a sample site log page. Make copies of the sample or design your own site log to meet the needs of your site and equipment.



Installing the Cisco 7206

This chapter explains the procedures for installing and starting the Cisco 7206. The chapter contains the following sections:

- [Rack-Mounting the Cisco 7206, page 3-2](#)
- [General Tabletop or Workbench Installation, page 3-9](#)
- [Providing a Chassis Ground Connection for the Router Chassis, page 3-12](#)
- [Connecting Port Adapter Cables, page 3-14](#)
- [Connecting I/O Controller Cables, page 3-14](#)
- [Connecting Power, page 3-20](#)
- [Starting the Cisco 7206, page 3-24](#)



Note

For installation and startup procedures for a Cisco 7206 as a router shelf in a Cisco AS5800 Universal Access Server, refer to the Cisco AS5800 Universal Access Server documentation listed in the Preface, “[Related Documentation](#)” section on page xiv.



Warning

Before you install, operate, or service the system, read the *Site Preparation and Safety Guide*. This guide contains important safety information you should know before working with the system.



Warning

To be installed and maintained by service personnel as defined by AS/NZS 3260. Incorrect connection of this or connected equipment to a General Purpose Outlet could result in a hazardous situation. The telecommunications lines must be disconnected before unplugging the main power connection and while the housing is open.

A rack-mount and cable-management kit is included in the shipping container. The rack-mount brackets in the kit are for mounting the Cisco 7206 in standard, 19-inch-wide, four-post equipment racks or telco-type equipment racks. The rack-mount brackets are not suitable for use with other racks, such as 23-inch telco racks. The cable-management brackets are designed to relieve the strain on port adapter interface cables that are installed on port adapters in a Cisco 7206. If you are installing an equipment shelf or using mounting hardware other than that supplied with the chassis, review the guidelines in the “[Equipment Racks](#)” section on page 2-4 in Chapter 2, “[Preparing for Installation](#),” then proceed to the section “[General Tabletop or Workbench Installation](#)” in this chapter.

If you do not plan to install your Cisco 7206 in an equipment rack, proceed to the “[General Tabletop or Workbench Installation](#)” section on page 3-9.

Rack-Mounting the Cisco 7206

The chassis mounts to two rack posts with brackets that attach to either the front or the rear sides of the chassis. The inside width between the two posts or mounting strips (left and right) must be at least 17 inches (43.18 cm).

Some equipment racks provide a power strip along the length of one of the mounting strips. [Figure 3-1](#) shows a typical four-post equipment rack with a power strip along one of the back posts. If your rack has this feature, consider the position of the strip when planning fastener points and ensure that you will be able to pull port adapters and other FRUs straight out of their respective slots.

The inlet and exhaust ports for cooling air are located on the right and left of the chassis, respectively, so multiple routers can be stacked in a rack with little or no vertical clearance.

Figure 3-1 Typical Four-Post Equipment Rack Posts and Mounting Strips

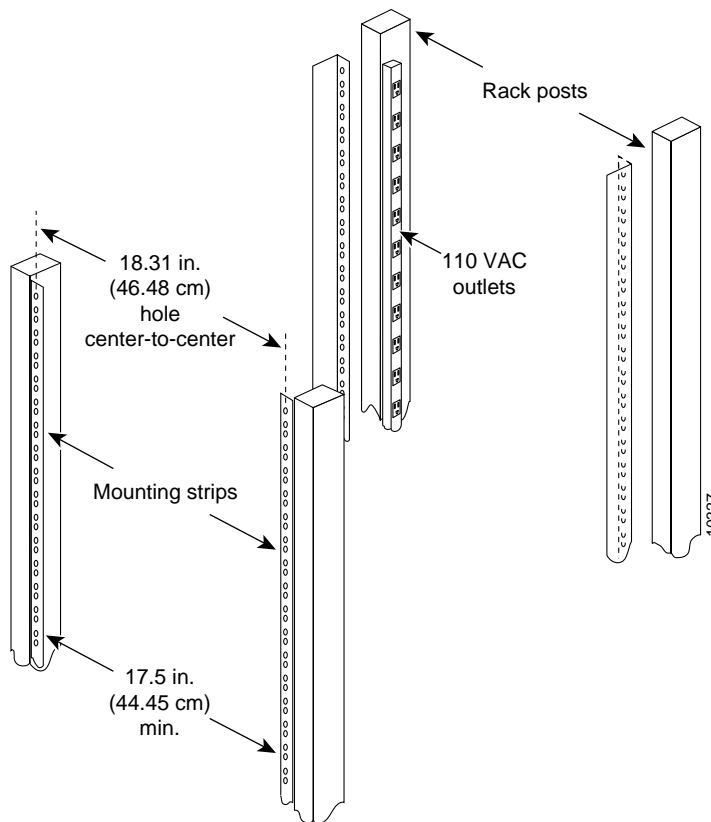

If you want the port adapter end (the front) of the chassis recessed in the rack, install the rack-mount brackets at the front or rear of the chassis in the orientation shown in [Figure 3-2](#). If you want the front of the chassis protruding from the rack, install the rack-mount brackets at the front or rear of the chassis in the orientation shown in [Figure 3-3](#).

Figure 3-2 Installing the Chassis in a Four-Post Rack—Front Installation Shown

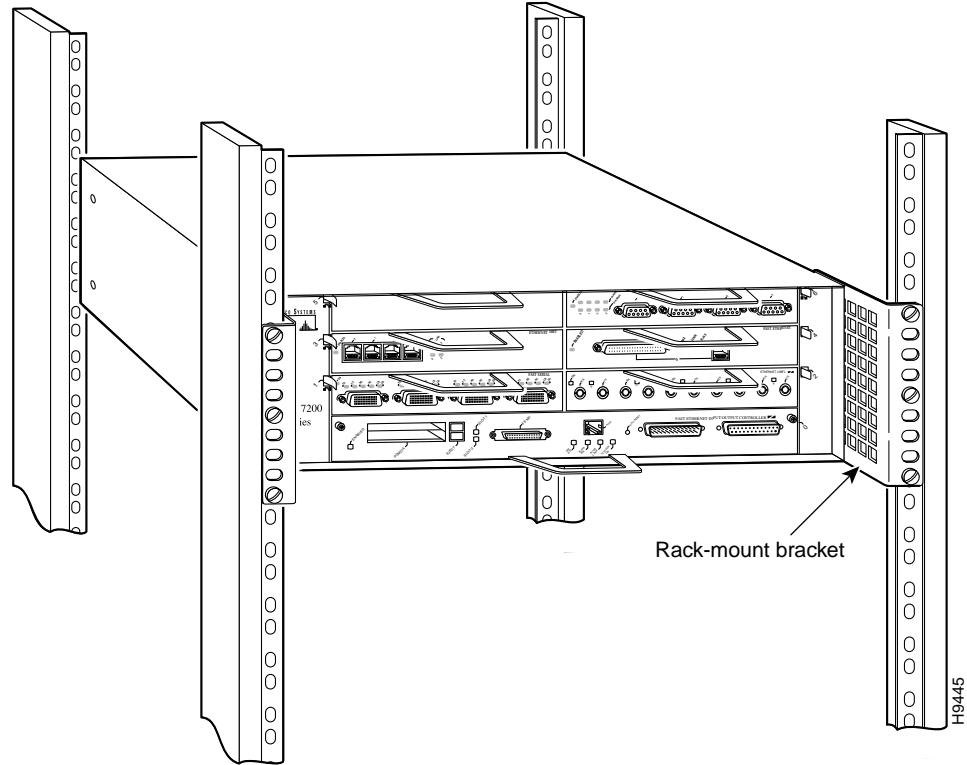
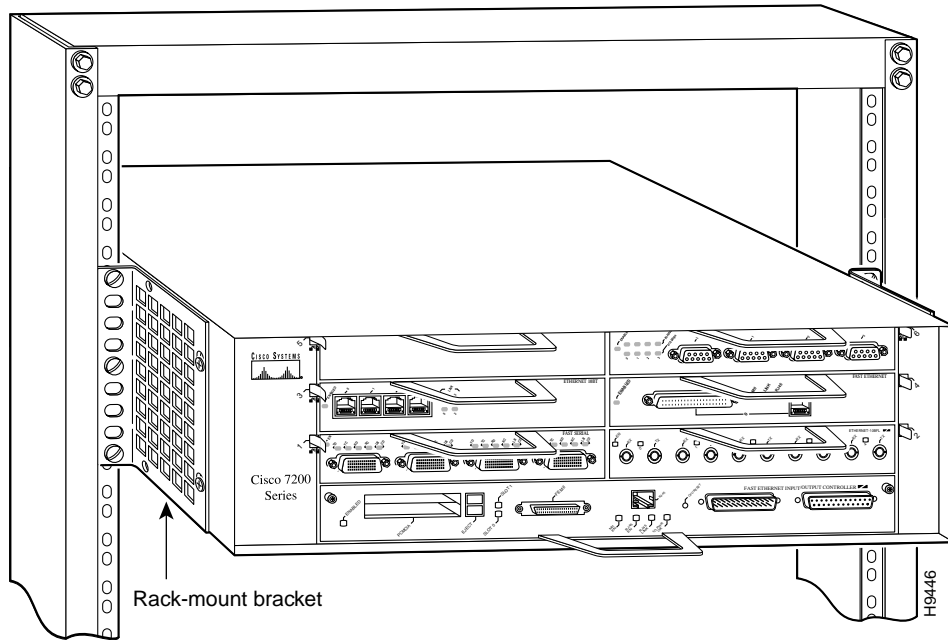

Figure 3-3 Installing the Chassis in a Telco-Type Rack—Front Installation Shown



If you plan to install the cable-management brackets on a Cisco 7206 that you are rack-mounting, you *must* install the cable-management brackets and the rack-mount brackets on the chassis *before* you install the chassis in the rack.

There are two cable-management bracket configurations when you rack-mount the Cisco 7206 from the front. In the first configuration, the cable-management brackets are installed over the rack-mount brackets, and four screws secure both sets of brackets to the chassis. (Refer to Figure 3-4.) In the second configuration, two screws secure each rack-mount bracket to the chassis, and two additional screws secure each cable-management bracket to a rack-mount bracket. (Refer to Figure 3-5.)

Figure 3-4 Rack-Mounting the Chassis in a Telco-Type Rack with Installed Cable-Management Brackets—Front Installation Shown

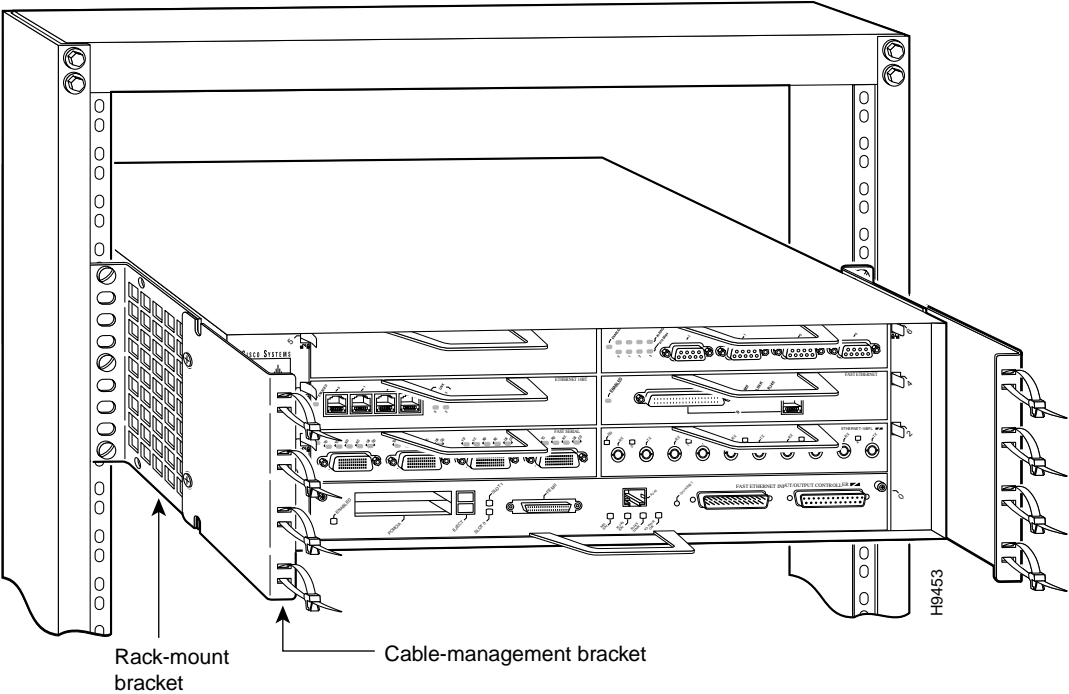
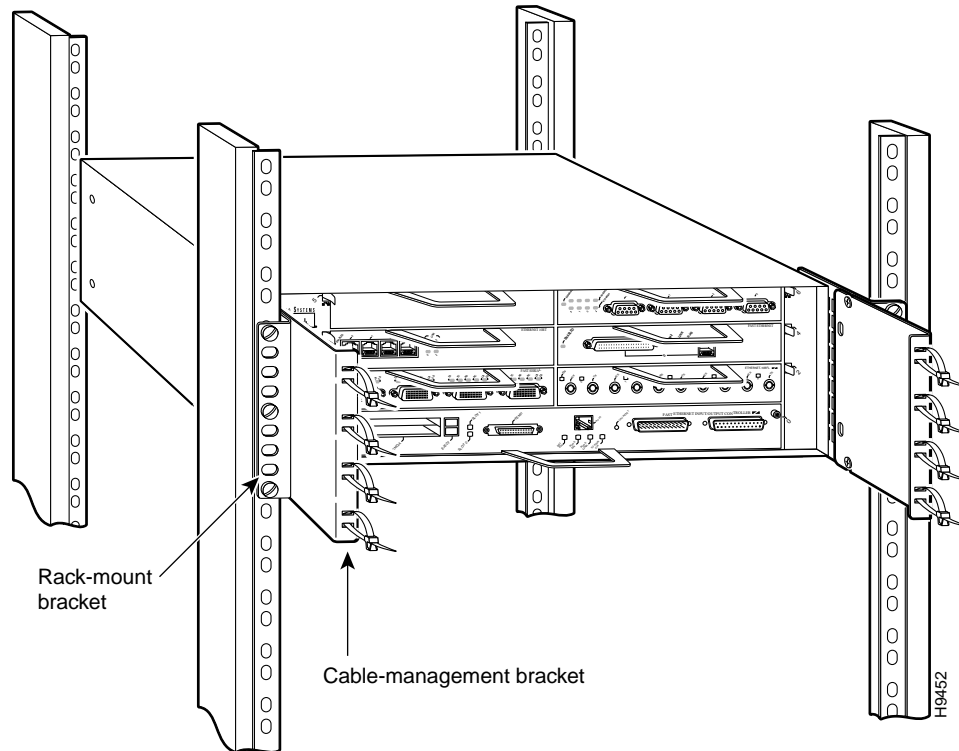

Figure 3-5 Rack-Mounting the Chassis in a Four-Post Rack with Installed Cable-Management Brackets—Front Installation Shown



If you are rack-mounting a Cisco 7206 router from the rear, the rack-mount brackets are installed at the rear of the chassis, and the cable-management brackets are installed at the front of the chassis. You must install both sets of brackets *before* you install the chassis in the rack.

Attaching the Chassis Rack-Mount and Cable-Management Brackets

This section explains how to install the rack-mount and cable-management brackets at the front and the rear of the Cisco 7206. Before installing the chassis in the rack, you must install a rack-mount bracket on each side of the front or rear of the chassis. If you are rack-mounting the chassis from the front and you plan to use the cable-management brackets, you must install the cable-management brackets when you install the rack-mount brackets on the chassis.

If you are rack-mounting the chassis from the rear, you may install the rack-mount and cable-management brackets separately; however, both sets of brackets must be installed on the chassis before the chassis is installed in the rack.

The parts and tools required for installing the rack-mount and cable-management brackets are listed in [Chapter 2, “Preparing for Installation,”](#) the [“Tools for Installation”](#) section on page 2-8.

Installing the Brackets on the Front of the Chassis

To install the rack-mount and cable-management brackets on a Cisco 7206 for a front rack-mount configuration, complete the following steps:

- Step 1** Locate the threaded holes in the front sides of the chassis. If you plan to use the cable-management brackets in your rack-mount configuration, proceed with Step 2. If you do not plan to use the cable-management brackets, skip to Step 3.
- Step 2** If you want the front of the chassis protruding from the rack, align the first rack-mount bracket and the first cable-management bracket to the threaded holes in the right side of the chassis as shown in [Figure 3-6](#).
- If you want the front of the chassis recessed in the rack, align the first rack-mount bracket to the threaded holes in the right side of the chassis as shown in [Figure 3-7](#).

Figure 3-6 *Installing the Rack-Mount Brackets on the Front of the Chassis so the Front Protrudes from the Rack*

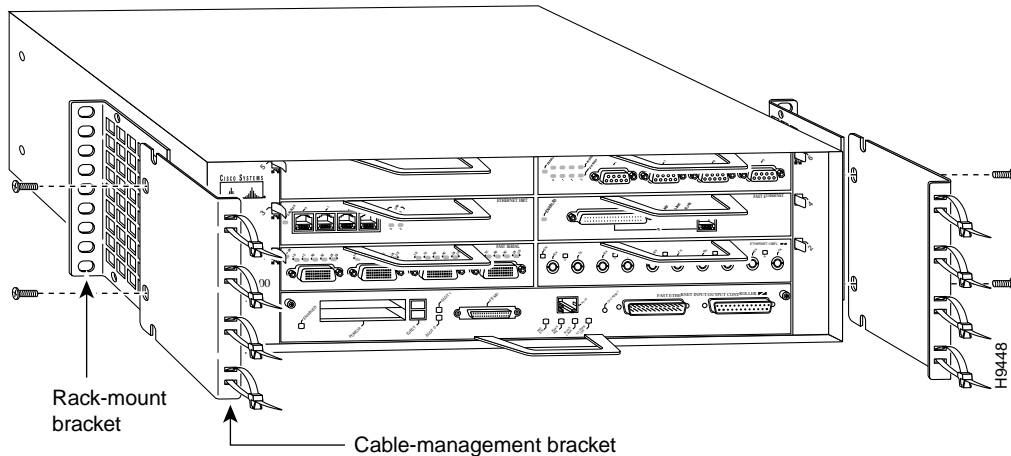
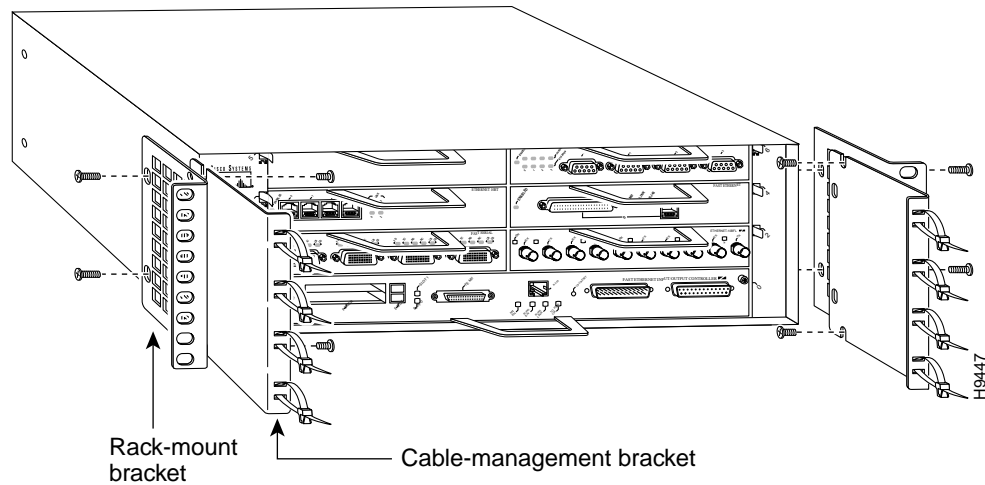

Figure 3-7 Installing the Rack-Mount Brackets on the Front of the Chassis so the Front Is Recessed in the Rack



- Step 3** If you aligned the first rack-mount bracket and cable-management bracket to the right side of the chassis, thread two M4 x 8-mm Phillips flathead screws through both brackets and into the side of the chassis. Use a number 2 Phillips screwdriver to tighten the screws. (Refer to [Figure 3-6](#).)
- If you aligned only the first rack-mount bracket to the right side of the chassis, thread two M4 x 8-mm Phillips flathead screws through the bracket into the side of the chassis and use a number 2 Phillips screwdriver to tighten the screws. Then align the first cable-management bracket to the rack-mount bracket and thread two M4 x 8-mm Phillips flathead screws through the two brackets. Use a number 2 Phillips screwdriver to tighten the screws. (Refer to [Figure 3-7](#).)
- Step 4** Repeat Step 1 through Step 3 for the other cable-management bracket (if required) and rack-mount bracket.

This completes the procedure for installing the rack-mount and cable-management brackets on a Cisco 7206 for a front rack-mount configuration.

Installing Brackets on the Rear of the Chassis

To install the rack-mount and cable-management brackets on a Cisco 7206 for a rear rack-mount configuration, complete the following steps:

- Step 1** Locate the threaded holes in the rear sides of the chassis.
- Step 2** Align the first rack-mount bracket to the threaded holes in the right side of the chassis.
- If you want the front of the chassis protruding from the rack, align the rack-mount bracket to the chassis as shown in [Figure 3-8](#). If you want the front of the chassis recessed in the rack, align the rack-mount bracket to the chassis as shown in [Figure 3-9](#).

Figure 3-8 Installing the Rack-Mount Brackets on the Rear of the Chassis so the Front Protrudes from the Rack

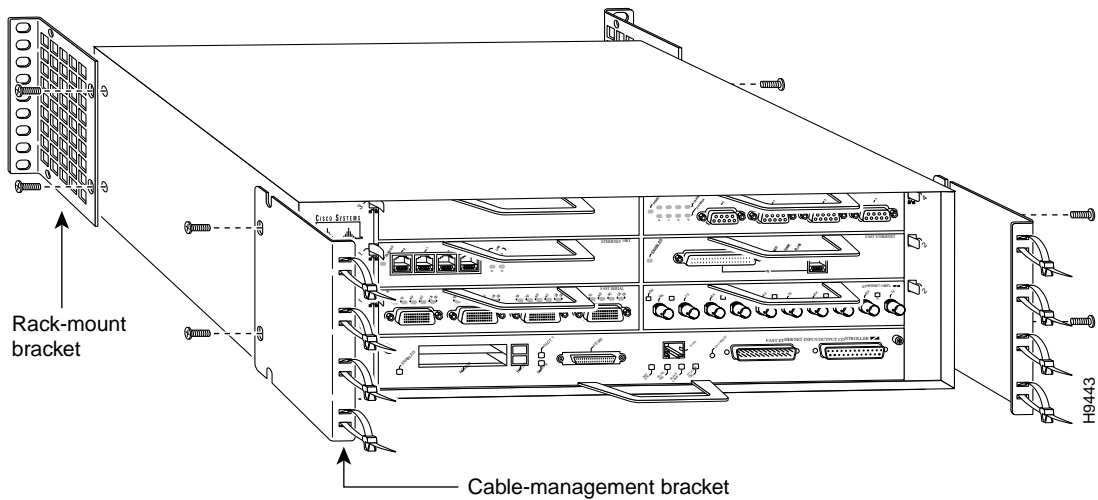
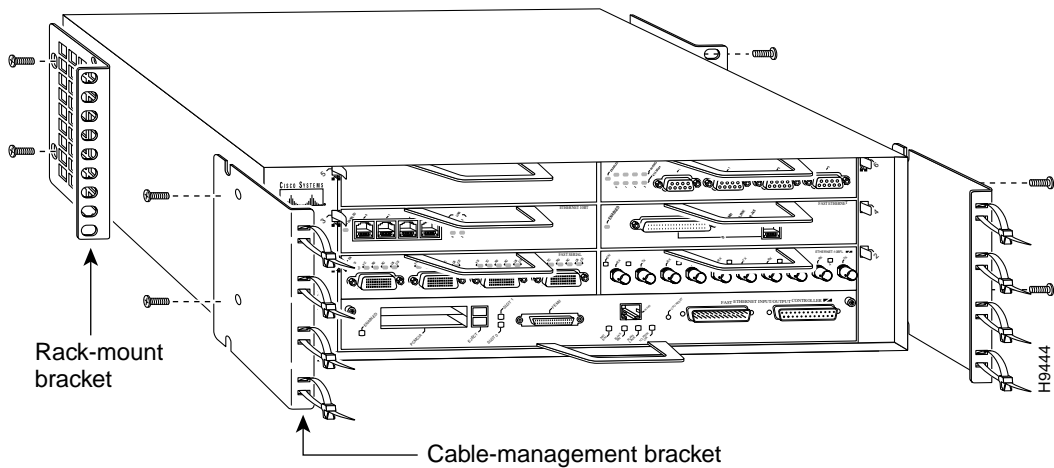

Figure 3-9 Installing the Rack-Mount Brackets on the Rear of the Chassis so the Front Is Recessed in the Rack



- Step 3** Thread two M4 x 8-mm Phillips flathead screws through the rack-mount bracket and into the side of the chassis. Use a number 2 Phillips screwdriver to tighten the screws.
- Step 4** Repeat [Step 1](#) through [Step 3](#) for the other rack-mount bracket.
- Step 5** If you plan to include the cable-management brackets in your rear rack-mount configuration, align the first cable-management bracket to the threaded holes in the front side of the chassis. (Refer to [Figure 3-8](#) and [Figure 3-9](#).)
- Step 6** Thread two M4 x 8-mm Phillips flathead screws through the bracket and into the chassis. Use a number 2 Phillips screwdriver to tighten the screws.
- Step 7** Repeat [Step 5](#) and [Step 6](#) for the other cable-management brackets.

This completes the procedure for installing the rack-mount brackets and cable-management brackets on the Cisco 7206. Proceed to the following section, “[Installing the Chassis in the Rack.](#)”

Installing the Chassis in the Rack

After installing the brackets on the chassis, mount the router by securing the rack-mount brackets to two posts or mounting strips in the rack using the six slotted screws provided. Because the brackets support the weight of the entire chassis, be sure to use all six slotted screws to fasten the two rack-mount brackets to the rack posts. [Figure 3-2](#), [Figure 3-3](#), [Figure 3-4](#), and [Figure 3-5](#) show typical installations in 19-inch, four-post and telco-type equipment racks.

We recommend that you allow at least 1 or 2 inches (2.54 or 5.08 cm) of vertical clearance between the router and any equipment directly above and below it.

To install the chassis in the rack, complete the following steps:

-
- Step 1** On the chassis, ensure that all captive screws on the network processing engine, the I/O controller, and each power supply are tightened and the port adapter levers are in the locked position.
- Step 2** Make sure that your path to the rack is unobstructed. If the rack is on wheels, ensure that the brakes are engaged or that the rack is otherwise stabilized.
-  **Note** Two people should perform Step 3 through Step 6.
-
- Step 3** Position the chassis so that the front end is closest to you. Lift the chassis and move it to the rack. To prevent injury, avoid sudden twists or moves.
- Step 4** Slide the chassis into the rack, pushing it back until the brackets (installed at the front or rear of the chassis) meet the mounting strips or posts on both sides of the equipment rack.
- Step 5** While keeping the brackets flush against the posts or mounting strips, position the router so the holes in the brackets are aligned with those in the mounting strips.
- Step 6** Insert all six 10-32 x 3/8 slotted screws (three on each side) through the brackets and into the mounting strip (use the top and bottom bracket holes, as shown in [Figure 3-2](#), [Figure 3-3](#), [Figure 3-4](#), and [Figure 3-5](#)). Using a 1/4-inch, flat-blade screwdriver, tighten all the screws.
-

This completes the procedure for installing the chassis in the rack. Proceed to the “[Connecting Port Adapter Cables](#)” section on page 3-14 to continue the installation.

General Tabletop or Workbench Installation

The router should already be in the area where you will install it, and your installation location should already be determined. If not, refer to the “[Site Requirements](#)” section on page 2-2 in [Chapter 2](#), “[Preparing for Installation.](#)”

When installing the Cisco 7206 on a workbench or tabletop, ensure that the surface is clean and in a safe location and that you have considered the following:

- The router requires at least 3 inches (7.62 cm) of clearance at the inlet and exhaust vents (the right and left sides of the router).

- The router should be installed off the floor. (Dust that accumulates on the floor is drawn into the interior of the router by the cooling fans. Excessive dust inside the router can cause overtemperature conditions and component failures.)
- There must be approximately 19 inches (48.3 cm) of clearance at the front and rear of the router for installing and replacing router FRUs, or accessing network cables or equipment.
- Port adapter and power supply filler panels are installed.
- The router will receive adequate ventilation (it is not being installed in an enclosed cabinet where ventilation is inadequate).
- If you plan to install the cable-management brackets on the front of the chassis, you have unpacked and set aside the two cable-management brackets and four M4 x 8-mm Phillips flathead screws.
- An adequate chassis ground (earth) connection for your router chassis.



Note We strongly recommend that you provide a chassis ground connection. Refer to the [“Providing a Chassis Ground Connection for the Router Chassis”](#) section on page 3-12 for instructions.

Following are the steps for installing the Cisco 7206 on a workbench or tabletop:

-
- Step 1** Remove any debris and dust from the tabletop or workbench, as well as the surrounding area. Also make sure your path between the router and its new location is unobstructed.
 - Step 2** On the chassis, ensure that all captive screws on the network processing engine, the I/O controller, and each power supply are tightened and the port adapter levers are in the locked position.
 - Step 3** Lift the chassis by placing your hands around the chassis sides and lifting the chassis from underneath. To prevent injury, avoid sudden twists or moves.
 - Step 4** Place the router on the tabletop or workbench.
 - Step 5** Ensure that there is at least 3 inches (7.62 cm) of clearance at the inlet and exhaust vents of the router and no exhaust air from other equipment will be drawn into the chassis. Also, ensure that there is approximately 19 inches (48.3 cm) of clearance at the front and rear of the chassis.
-

This completes the general installation.

Installing the Cable-Management Brackets

To install the cable-management brackets on the Cisco 7206, complete the following steps:

-
- Step 1** Locate the threaded holes in the front sides of the chassis.
 - Step 2** Align the first cable-management bracket to the threaded holes in the right side of the chassis. (Refer to [Figure 3-5](#).)
 - Step 3** Thread two M4 x 8-mm Phillips flathead screws through the bracket and into the chassis. Use a number 2 Phillips screwdriver to tighten the screws.
 - Step 4** Repeat Step 1 through Step 3 for the other cable-management bracket.
-

This completes the steps for installing the cable-management brackets on the Cisco 7206.

Securing the Port Adapter Cables

To secure port adapter interface cables to the cable-management brackets, complete the following steps:



Note

The eight removable tie wraps installed on the cable-management brackets secure port adapter interface cables to the brackets. We recommend that you use the tie wraps that shipped with the cable-management brackets. You can use standard tie wraps; however, you will have to cut and replace them with new tie wraps when you want to release or secure an interface cable to a bracket.

Step 1 Select a tie wrap and release its locking mechanism.

Step 2 Carefully lace the interface cables from a port adapter installed in the chassis between the two ends of the unlocked tie wrap.



Note Be sure to leave a small service loop in the interface cable before securing it to the cable-management bracket.

Step 3 With the interface cables between the ends of the tie wrap and the interface cables service loop in place, tighten the cable tie down around the interface cables until they are secured against the cable-management bracket. (Refer to [Figure 3-10](#).)

Figure 3-10 Securing Interface Cables to the Cable-Management Brackets

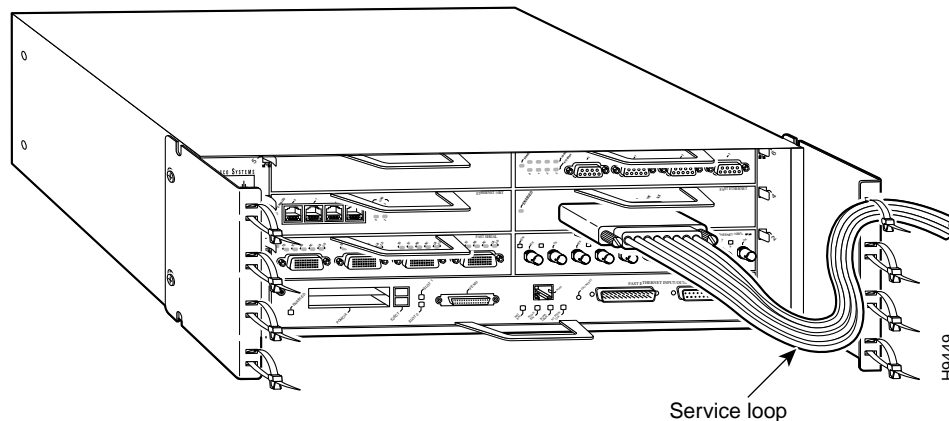

Step 4 Repeat Step 1 through Step 3 for any other port adapter interface cables installed in the router.

This completes the procedure for securing port adapter interface cables to the cable-management brackets. Proceed to the [“Providing a Chassis Ground Connection for the Router Chassis”](#) section on [page 3-12](#), to continue the installation.

Providing a Chassis Ground Connection for the Router Chassis

Before you connect power or turn on power to your router, we strongly recommend that you provide an adequate chassis ground (earth) connection for your router's chassis. Chassis grounding receptacles are provided on each Cisco 7206 router chassis. (Refer to [Figure 3-11](#).)



Note

Older Cisco 7206 router chassis do not have the grounding receptacles. If you have a Cisco 7206 chassis that does not have the grounding receptacles and you want to make appropriate ground connections to your router, you must order a Cisco 7206 router chassis that has the grounding receptacles.

To ensure the chassis grounding connection that you provide is adequate, you will need the following parts and tools:

- One grounding lug—Must have two number-10 screw holes that have a 0.63-inch (16.002-mm) spacing between them, and a wire receptacle large enough to accept a 6-AWG multistrand, copper wire. (See [Figure 3-12](#).) This grounding lug is not available from Cisco Systems; electrical-connector vendors provide this type of grounding lug.
- Two Phillips-head machine screws with locking washers—M5 (metric), 0.031-inch (0.8-mm) pitch, 0.315-inch (8-mm) length. These screws are not available from Cisco Systems; they are available from any commercial hardware vendor.
- One grounding wire—6-AWG, 0.162-inch (4.115-mm) diameter, with approximately 0.108-inch (2.743-mm) insulation, for a total wire diameter of approximately 0.27 inches (6.858 mm). The wire length is dependent on your router location and site environment. This wire is not available from Cisco Systems; it is available from any commercial cable vendor.
- Number 2 Phillips screwdriver
- Crimping tool large enough to accommodate the diameter of the wire receptacle on your grounding lug
- Wire stripper

Figure 3-11 Locating the Chassis Grounding Receptacles

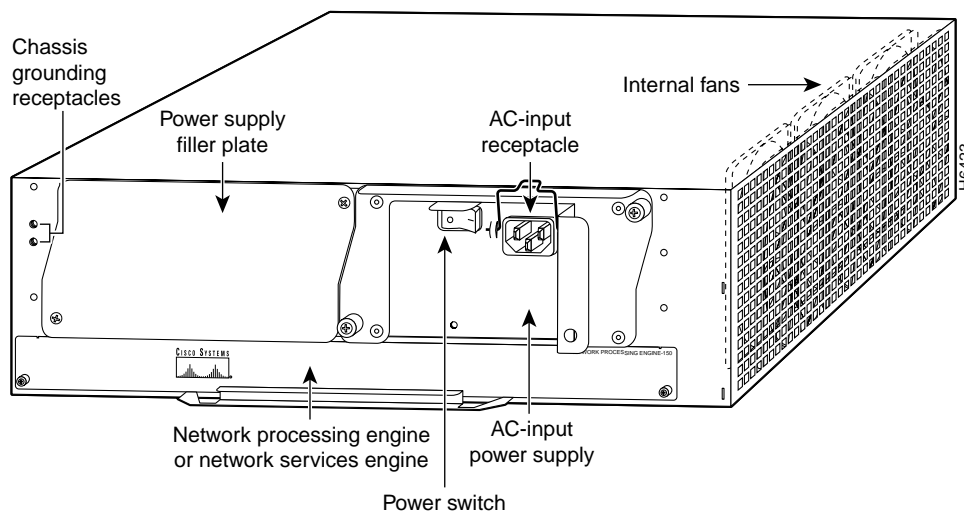

Use the following procedure to attach the grounding lug to the chassis grounding receptacles on your router chassis:

-
- Step 1** Locate the chassis grounding receptacles on your router chassis. (See [Figure 3-11](#).)
- Step 2** Insert the two screws through the holes in the grounding lug. (See [Figure 3-12](#).) Ensure that the grounding lug does not interfere with other router hardware, such as power supplies or the network processing engine.

Figure 3-12 Attaching a Grounding Lug to the Chassis Grounding Receptacles

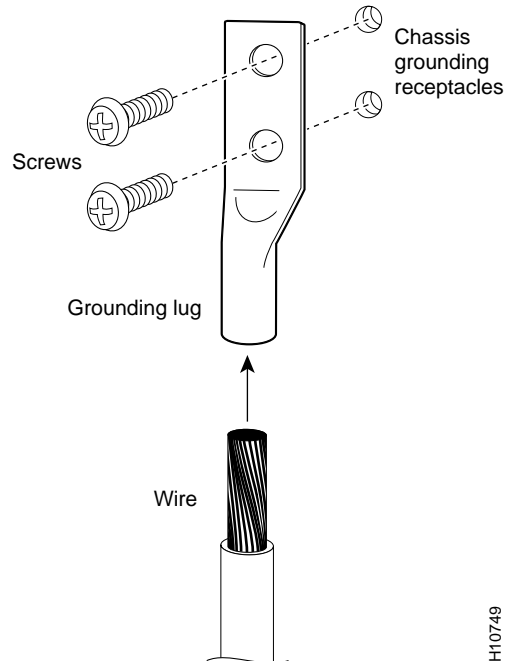

- Step 3** Use the Phillips screwdriver to carefully tighten the screws until the grounding lug is held firmly to the chassis. Do not overtighten the screws.
- Step 4** Use the wire stripper to strip one end of the 6-AWG wire approximately 0.75 inches (19.05 mm).
- Step 5** Insert the 6-AWG wire into the wire receptacle on the grounding lug. (See [Figure 3-12](#).)
- Step 6** Use the crimping tool to carefully crimp the wire receptacle around the wire; this step is required to ensure a proper mechanical connection.
- Step 7** Connect the opposite end of the grounding wire to the appropriate grounding point at your site to ensure an adequate chassis ground.
-

This completes the procedure for providing a chassis ground connection.

Connecting Port Adapter Cables

The instructions for connecting the cables for each port adapter installed in the Cisco 7206 are contained in the respective configuration note for each port adapter (service adapters do not have cables). For example, if you are connecting the cables for a PA-A3 enhanced ATM port adapter, refer to the configuration note *PA-A3 Enhanced ATM Port Adapter Installation and Configuration*. This document is available on Cisco.com.

Instructions for securing port adapter interface cables to the cable-management brackets are contained in the [“General Tabletop or Workbench Installation”](#) section on page 3-9.

Connecting I/O Controller Cables

The console and auxiliary ports for the Cisco 7206 are located on the I/O controller. The I/O controller also has an optional Fast Ethernet port (refer to [Figure 3-13](#)). This section contains connection equipment and pinout information for the console, auxiliary, and Fast Ethernet ports on the I/O controller.

Figure 3-13 Cisco 7206 I/O Controller Connections

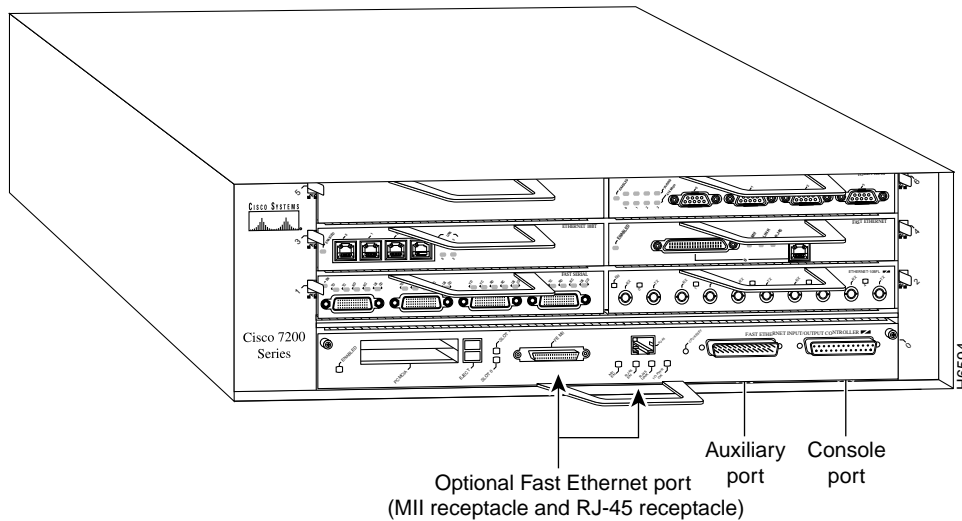

Console and Auxiliary Port Connection Equipment

The I/O controller has two EIA/TIA-232 ports: a DCE-mode console port and a DTE-mode auxiliary port. (Refer to [Figure 3-14](#).) The console port is a DCE DB-25 connector for connecting a data terminal, which you will use to configure the interfaces and bring up the router. The auxiliary port is a DTE DB-25 plug for connecting a modem or other DCE device (such as a CSU/DSU or other router) to the Cisco 7206.

**Note**

Both the console and auxiliary ports are asynchronous serial ports; any devices connected to these ports must be capable of asynchronous transmission. (Asynchronous is the most common type of serial device; for example, most modems are asynchronous devices.)

Before connecting a terminal to the console port, configure the terminal to match the router console port as follows: 9600 baud, 8 data bits, no parity, 2 stop bits (9600 8N2). You need an EIA/TIA-232 DCE console cable to connect the terminal to the console port. After you establish normal router operation, you can disconnect the terminal.

You must supply your own interface cable between the auxiliary port and the equipment you are connecting. For console and auxiliary port pinouts, refer to the following sections “[Console Port Signals](#)” and “[Auxiliary Port Signals](#).”

Figure 3-14 Console and Auxiliary Port Connections

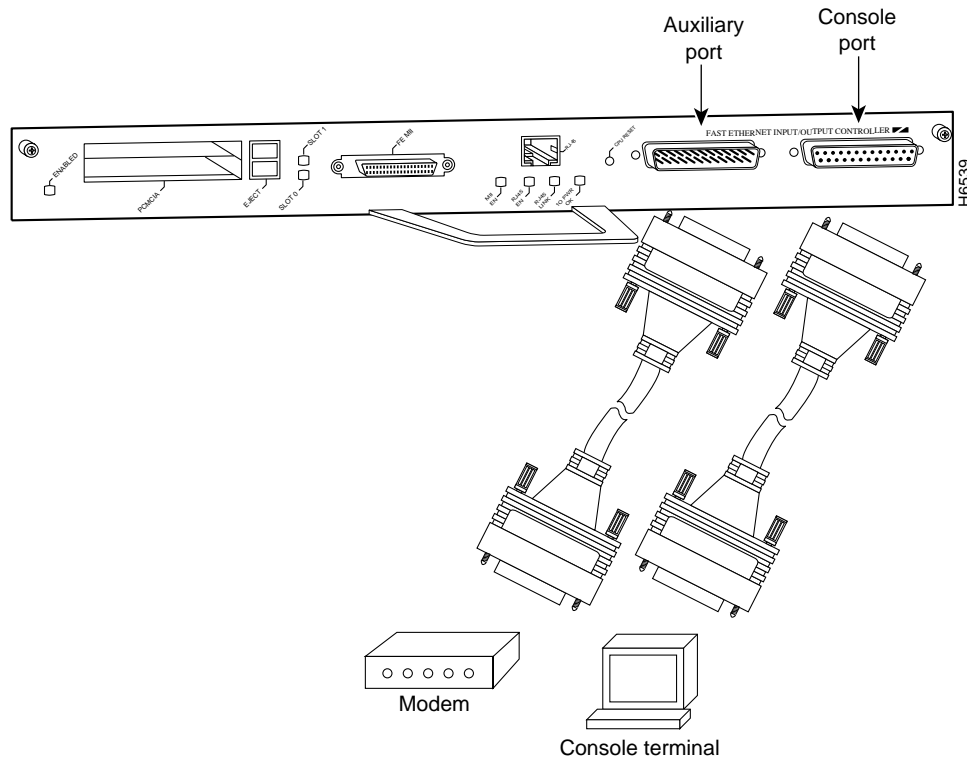

Console Port Signals

[Table 3-1](#) lists the signals used on the console port. The console port does not support modem control or hardware flow control. Both Data Set ready (DSR) and Data Carrier Detect (DCD) signals are active when the system is running. The Request To Send (RTS) signal tracks the state of the Clear to Send (CTS) input. The console port requires a straight-through EIA/TIA-232 cable.

Table 3-1 Console Port Signals

Pin	Signal	Direction	Description
1	GND	–	Ground
2	TxD	<—	Transmit Data
3	RxD	—>	Receive Data
6	DSR	—>	Data Set Ready (always on)
7	GND	–	Ground
8	DCD	—>	Data Carrier Detect (always on)

Auxiliary Port Signals

Table 3-2 lists the signals used on the auxiliary port. The auxiliary port supports hardware flow control and modem control.

Table 3-2 Auxiliary Port Signals

Pin	Signal	Direction	Description
2	TxD	—>	Transmit Data
3	RxD	<—	Receive Data
4	RTS	—>	Request To Send (used for hardware flow control)
5	CTS	<—	Clear To Send (used for hardware flow control)
6	DSR	<—	Data Set Ready
7	Signal Ground	–	Signal Ground
8	CD	<—	Carrier Detect (used for modem control)
20	DTR	—>	Data Terminal Ready (used for modem control only)

Fast Ethernet Connection Equipment

The I/O controller is available with or without a Fast Ethernet port. The I/O controller with a Fast Ethernet port is equipped with either a single MII port or an MII port and an RJ-45 port (only one port can be used at a time). Although still supported by Cisco Systems, the I/O controller equipped with the single MII port was discontinued as an orderable product in May 1998. The following sections explain Fast Ethernet MII and RJ-45 connection equipment.

Fast Ethernet MII Connection Equipment

The MII port on the I/O controller is a 40-pin, D-shell type connector that is configurable for 100 megabits per second (Mbps) full-duplex or half-duplex (half-duplex is the default). The MII port supports IEEE 802.3u interfaces compliant with the 100BASEX and 100BASET standards. The MII connection requires an external transceiver that permits connection to multimode fiber for 100BASEFX or 100BASET4 physical media (refer to [Figure 3-15](#)).

Figure 3-15 Fast Ethernet Port Connection

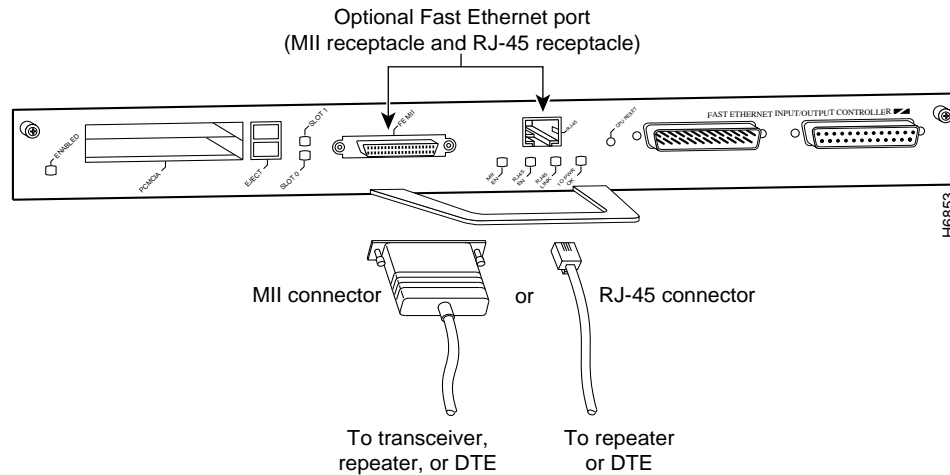

Depending on the type of media you use between the MII connection and your switch or hub, the network side of your 100BASET transceiver should be appropriately equipped with ST-type connectors (for optical fiber), BNC connectors, and so forth.

[Figure 3-16](#) shows the pin orientation of the MII port on the I/O controller.

The MII port uses two 56 screw-type locks, called jackscrews, to secure the cable or transceiver to the port. MII cables and transceivers have knurled thumbscrews that you fasten to the jackscrews on the MII connector and tighten with your fingers. Use the jackscrews to secure your MII cable to the MII port.

Figure 3-16 MII Port

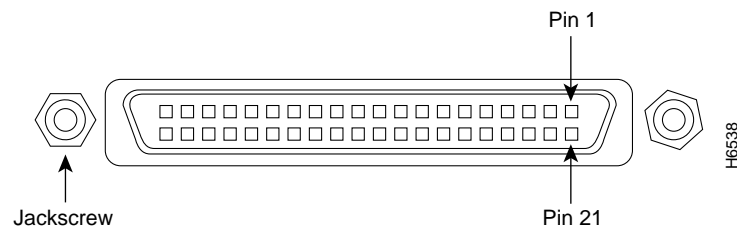

[Table 3-3](#) lists the pinouts and signals for the I/O controller MII port.

Table 3-3 MII Port Pinout

Pin ¹	In	Out	I/O	Description
14–17	–	Yes	–	Transmit Data (TxD)
12	Yes	–	–	Transmit Clock (Tx_CLK) ²
11	–	Yes	–	Transmit Error (Tx_ER)
13	–	Yes	–	Transmit Enable (Tx_EN)
3	–	Yes	–	MII Data Clock (MDC)
4–7	Yes	–	–	Receive Data (RxD)
9	Yes	–	–	Receive Clock (Rx_CLK) ²
10	Yes	–	–	Receive Error (Rx_ER)
8	Yes	–	–	Receive Data Valid (Rx_DV)
18	Yes	–	–	Collision (COL)
19	Yes	–	–	Carrier Sense (CRS)
2	–	–	Yes	MII Data Input/Output (MDIO)
22–39	–	–	–	Common (ground)
1, 20, 21, 40	–	–	–	+5.0 volts (V)

1. Any pins not indicated are not used.
2. Tx_CLK and Rx_CLK are provided by the external transceiver.

Ethernet and Fast Ethernet RJ-45 Connection Equipment

The RJ-45 port on the I/O controller is configurable for 100 Mbps full-duplex or half-duplex (half-duplex is the default) and supports IEEE 802.3 (Ethernet) and IEEE 802.3u interfaces compliant with 10BASET and 100BASETX specifications.

The RJ-45 port supports standard straight-through and crossover Category 5 unshielded twisted-pair (UTP) cables (refer to [Figure 3-15](#)). Cisco Systems does not supply Category 5 UTP cables; these cables are available commercially.

[Figure 3-17](#) shows the RJ-45 port and connector. [Table 3-4](#) lists the pinouts and signals for the RJ-45 port.

Figure 3-17 RJ-45 Port and Plug

Table 3-4 RJ-45 Port Pinout

Pin	Description
1	Receive Data + (RxD+)
2	RxD-
3	Transmit Data + (TxD+)
6	TxD-

**Note**

With reference to the RJ-45 pinout in [Table 3-4](#), proper common-mode line terminations should be used for the unused Category 5 UTP cable pairs 4/5 and 7/8. Common-mode line termination reduces electromagnetic interference (EMI).

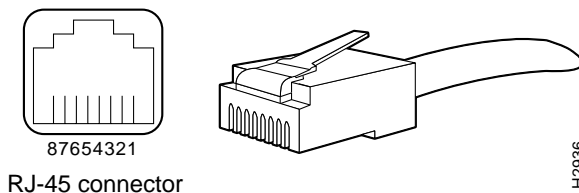
Depending on your I/O controller RJ-45 interface cabling requirements, use the pinouts shown in [Figure 3-18](#) and [Figure 3-19](#) for straight-through and crossover twisted-pair cable connections.

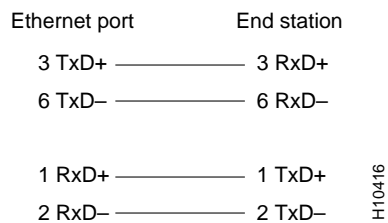
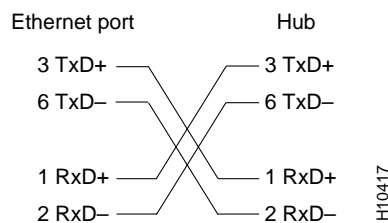
Figure 3-18 Straight-Through Cable Pinout, I/O Controller RJ-45 Connection to an End Station or DTE**Figure 3-19 Crossover Cable Pinout, I/O Controller RJ-45 Connection to an End Station or DTE**

To identify the RJ-45 cable type, hold the two ends of the cable next to each other so you can see the colored wires inside the ends, as shown in [Figure 3-20](#).

Figure 3-20 RJ-45 Cable Identification

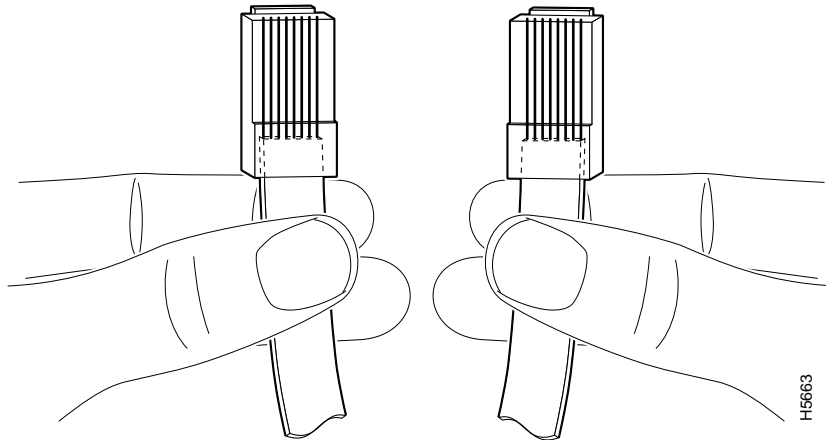

Examine the sequence of colored wires to determine the type of RJ-45 cable, as follows:

- Straight-through—The colored wires are in the same sequence at both ends of the cable.
- Crossover—The first (far left) colored wire at one end of the cable is the third colored wire at the other end of the cable, and the second colored wire at one end of the cable is the sixth colored wire at the other end of the cable.

Connecting Power



Warning

Before you install, operate, or service the system, read the *Site Preparation and Safety Guide*. This guide contains important safety information you should know before working with the system.

This section provides the procedures for connecting AC-input and DC-input power to your Cisco 7206.



Warning

This unit might have more than one power cord. To reduce the risk of electric shock, disconnect the two power supply cords before servicing the unit.



Note

Detailed instructions for handling and replacing the Cisco 7206 power supplies are contained in the configuration notes *280-Watt AC-Input Power Supply Replacement Instructions* and *280-Watt DC-Input Power Supply Replacement Instructions*. These configuration notes are available on Cisco.com.

Connecting AC-Input Power

Connect a 280W AC-input power supply as follows:

- Step 1** At the rear of the router, check that the power switch is in the off (O) position.
- Step 2** Slide the cable-retention clip up, away from the AC receptacle, and plug in the power cable.

- Step 3** Secure the cable in the power supply AC receptacle by sliding the cable-retention clip down until it fits around the connector. The cable-retention clip provides strain relief for the AC power cable (refer to [Figure 3-21](#)).



Note For additional AC power cable strain relief, secure the cable to the power supply handle by inserting a nylon cable tie through the hole in the handle and around the cable.



Warning

The AC power supply for the Cisco 7206 has double pole/neutral fusing.

Figure 3-21 Connecting AC-Input Power

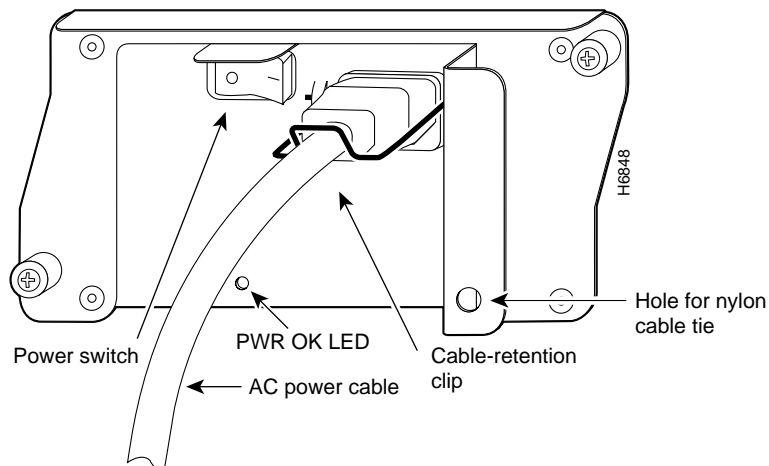

- Step 4** Plug the AC power supply cable into the AC power source.
- Step 5** Repeat Step 1 through Step 4 for the second power supply (if present).

This completes the procedure for connecting AC-input power.

Connecting DC-Input Power

Connect a 280W DC-input power supply as follows:



Note

The color coding of the DC-input power supply leads depends on the color coding of the DC power source at your site. Typically, green or green/yellow is used for ground. Make certain the lead color coding you choose for the DC-input power supply matches lead color coding used at the DC power source.

**Warning**

Before completing any of the following steps, and to prevent short-circuit or shock hazards, ensure that power is removed from the DC circuit. To ensure that all power is OFF, locate the circuit breaker on the panel board that services the DC circuit, switch the circuit breaker to the OFF position, and tape the switch handle of the circuit breaker in the OFF position.

**Warning**

When you install the unit, the ground connection must always be made first and disconnected last.

- Step 1** Ensure that no current is flowing through the DC power supply leads. To ensure that all power is OFF, locate the circuit breaker on the panel board that services the DC circuit, switch the circuit breaker to the OFF position, and tape the switch handle of the circuit breaker in the OFF position.
- Step 2** Using a wire stripper, strip approximately 0.55 inch (14 mm) from the -V, +V, and ground leads (refer to [Figure 3-22](#)).

Figure 3-22 Stripping the DC-Input Leads

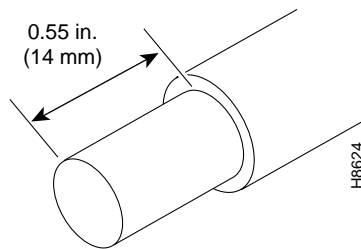

- Step 3** At the rear of the router, check that the power switch on the power supply is in the off (O) position (refer to [Figure 3-23](#)).
- Step 4** Insert the stripped end of the ground lead all the way into the ground lead receptacle on the DC-input power supply and tighten the receptacle screw using a 3/16-inch flat-blade screwdriver (refer to [Figure 3-23](#)).

Figure 3-23 Connecting DC-Input Power

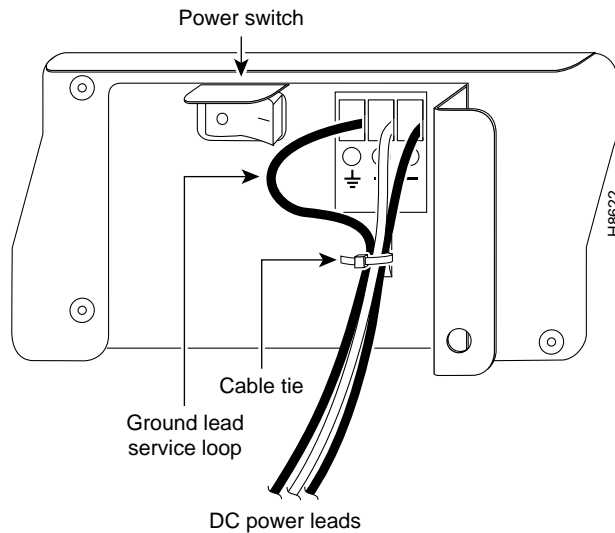

- Step 5** Insert the stripped end of the +V lead all the way into the +V lead receptacle and tighten the receptacle screw using the same 3/16-inch flat-blade screwdriver. Repeat this step for the –V lead.



Note Make sure the entire stripped end of each lead is inserted all the way into its receptacle. If any exposed wire at the stripped end of a lead is visible after inserting the lead into its receptacle, remove the lead from the receptacle, use the wire stripper to cut the stripped end of the lead, and repeat [Step 2](#) through [Step 5](#).

- Step 6** After tightening the receptacle screw for the ground, +V, and –V DC-input leads, use the cable tie (see [Figure 3-23](#)) to secure the three leads to the power supply faceplate.



Note When securing the ground, +V, and –V DC-input leads to the power supply faceplate, leave a small service loop in the ground lead to ensure that the ground lead is the last lead to disconnect from the power supply if a great deal of strain is placed on all three leads (refer to [Figure 3-23](#)).

- Step 7** Switch the circuit breaker to the ON position.



Note Each DC-input power supply operating at 24 VDC requires a minimum of 19A service. Each DC-input power supply operating at 48 VDC requires a minimum of 13A service. Each DC-input power supply operating at 60 VDC requires a minimum of 8A service.

The preceding values are absolute maximum values. Typical system configurations use substantially less. To obtain typical values for your configuration, contact your Cisco sales representative.

This product relies on the building's installation for short-circuit (overcurrent) protection. Ensure that a listed and certified fuse or circuit breaker, 35A minimum 60 VDC, is used on all current-carrying conductors. Site wiring and circuit breakers need to be sized to accommodate the maximum values for safety reasons.

This completes the procedure for connecting DC-input power. Proceed to the [“Starting the Cisco 7206” section on page 3-24](#) to start the router.

Starting the Cisco 7206

After installing your Cisco 7206 and connecting cables, start the router as follows:

-
- Step 1** Check for the following:
- Each port adapter is inserted in its slot and its respective port adapter lever is in the locked position.
 - The network processing engine and the I/O controller are inserted in their slots and their captive installation screws are tightened.
 - All network interface cables are connected to the port adapters.
 - A Flash memory card is installed in its PC card slot.
 - Each power cable is connected and secured with the cable-retention clip.
 - The console terminal is turned on.
- Step 2** At the rear of the router, place the power switch on the power supply in the on (I) position. Repeat this if a second power supply is installed. The green OK LED on the power supply turns on.
- Step 3** Listen for the fans; you should immediately hear them operating.
- Step 4** During the boot process, observe the system LEDs. The LEDs on most of the port adapters go on and off in irregular sequence. Some may go on, go out, and go on again for a short time. On the I/O controller, the IO power OK LED comes on immediately.
- Step 5** Observe the initialization process. When the system boot is complete (a few seconds), the network processing engine begins to initialize the port adapters and the I/O controller. During this initialization, the LEDs on each port adapter behave differently (most flash on and off).

The enabled LED on each port adapter goes on when initialization is completed, and the console screen displays a script and system banner similar to the following:

```
Cisco Internetwork Operating System Software
IOS (tm) 7200 Software (C7200-J-M), Version 11.1(17)CA
Copyright (c) 1986-1996 by cisco Systems, Inc.
Compiled Sun 21-Apr-96 04:10 by
```

- Step 6** When you start up the Cisco 7206 for the first time, the system automatically enters the setup command facility, which determines which port adapters are installed and prompts you for configuration information for each one. On the console terminal, after the system displays the system banner and hardware configuration, you will see the following System Configuration Dialog prompt:

```
--- System Configuration Dialog ---
```

```
At any point you may enter a questions mark '?' for help.
Use ctrl-c to abort configuration dialof at any prompt.
Default settings are in square brackets '['].
```

```
continue with configuration dialog? [yes]:
```

You have the option of proceeding with the setup command facility to configure the interfaces, or exiting from setup and using configuration commands to configure global (system-wide) and interface-specific parameters. You do not have to configure the interfaces immediately; however, you cannot enable the interfaces or connect them to any networks until you have configured them.

Many of the port adapter LEDs will not go on until you have configured the interfaces. To verify correct operation of each interface, complete the first-time startup procedures and configuration, and then refer to the configuration note for each port adapter for LED descriptions and to check the status of the interfaces.

If the system does not complete each of the steps in the startup procedure, proceed to [Chapter 6, “Troubleshooting the Installation,”](#) for troubleshooting recommendations and procedures.

Your installation is complete. Proceed to [Chapter 4, “Performing a Basic Configuration of the Cisco 7206.”](#)



Performing a Basic Configuration of the Cisco 7206

This chapter describes how to perform a basic configuration for your Cisco 7206. The chapter contains the following sections:

- [Using the Enable Secret and the Enable Password, page 4-1](#)
- [Configuring the Cisco 7206, page 4-2](#)
- [Performing Other Configuration Tasks, page 4-10](#)
- [Performing a Complex Configuration, page 4-11](#)



Note

For instructions about how to perform a basic configuration for a Cisco 7206 used as a router shelf in a Cisco AS5800 Universal Access Server, refer to the Cisco AS5800 Universal Access Server documentation listed in the Preface, [“Related Documentation” section on page xiv](#).

This chapter guides you through a basic Cisco 7206 configuration, which is sufficient for you to access your network. Complex configuration procedures are beyond the scope of this publication and can be found in the configuration publications listed in the Preface, [“Related Documentation” section on page xiv](#).

To configure the Cisco 7206 from a console, you need to connect a terminal to the router’s console port. Configuration requires access to the console port on the router’s I/O controller.

Using the Enable Secret and the Enable Password

The Cisco 7206 is administered using the Cisco command interpreter, called the EXEC. You must boot and log in to the router before you can enter an EXEC command. For security purposes the EXEC has two levels of access to commands, user EXEC mode and privileged EXEC mode.

The commands available at the user level are a subset of those available at the privileged level. Because many privileged-level EXEC commands are used to set operating parameters, you should password-protect these commands to prevent unauthorized use.

There are two commands you can use to set the password protection:

- **enable secret** *password* (which is a very secure, encrypted password)
- **enable password** (which is a less secure, or nonencrypted, password)

You must enter the correct password to gain access to privileged-level commands. The passwords should be different for maximum security. If you enter the same password for both during the setup script, the system will accept it, but you will receive a warning message indicating that you should enter a different password.

An enable secret password can contain from 1 to 25 uppercase and lowercase alphanumeric characters; an enable password can contain any number of uppercase and lowercase alphanumeric characters. In both cases, a number cannot be the first character. Spaces are also valid password characters; for example, “two words” is a valid password. Leading spaces are ignored; trailing spaces are recognized.

Configuring the Cisco 7206

You can configure the Cisco 7206 using one of the procedures described in the following sections:

- [Configuring the Cisco 7206 Using AutoInstall, page 4-2](#)
- [Configuring the Cisco 7206 Manually Using the Setup Facility, page 4-3](#)
- [Configuring the Cisco 7206 Using Configuration Mode, page 4-9](#)

Follow the procedure that best fits the needs of your network configuration.



Note

You need to acquire the correct network addresses from your system administrator or consult your network plan to determine correct addresses before you can complete the router configuration.

Before continuing the configuration process, check the current state of the router by entering the **show version** command. The **show version** command displays the release of Cisco IOS software that is available on the router.

Configuring the Cisco 7206 Using AutoInstall

The AutoInstall process is designed to configure the Cisco 7206 automatically after connection to your WAN. For AutoInstall to work properly, a Transmission Control Protocol/Internet Protocol (TCP/IP) host on your network must be preconfigured to provide the required configuration files. The TCP/IP host may exist anywhere on the network as long as the following two conditions are maintained:

1. The host must be on the remote side of the router synchronous serial connection to the WAN.
2. User Datagram Protocol (UDP) broadcasts to and from the router and the TCP/IP host are enabled.

This functionality is coordinated by your system administrator at the site where the TCP/IP host is located. You should not use AutoInstall unless the required files are available on the TCP/IP host. See the publications *Configuration Fundamentals Configuration Guide* and *Configuration Fundamentals Command Reference* for information about how AutoInstall works.

Complete the following steps to prepare your Cisco 7206 for the AutoInstall process:

-
- Step 1** Attach the appropriate synchronous serial cable to synchronous serial interface 0 on the router.
- Step 2** Turn the power switch on each power supply to the on (I) position. (This action turns on AC power to the router.)

The router loads the operating system image from Flash memory. If the remote end of the WAN connection is connected and properly configured, the AutoInstall process begins.

Once the AutoInstall process is completed, use the **copy running-config startup-config** command to write the configuration data to the router's nonvolatile random-access memory (NVRAM). Perform the following step to complete this task.

Step 3 At the # prompt, enter the following command:

```
Hostname# copy running-config startup-config
```



Note Completing this step saves the configuration settings that the AutoInstall process created to NVRAM. If you fail to do this, your configuration will be lost the next time you reload the router.

Configuring the Cisco 7206 Manually Using the Setup Facility

If you do not plan to use AutoInstall, do not connect the router's serial (WAN) cable to the channel service unit/data service unit (CSU/DSU). If the serial (WAN) cable is connected to the CSU/DSU and the router does not have a configuration stored in NVRAM, the router attempts to run AutoInstall at startup. The router may take several minutes to determine that AutoInstall is not set up to a remote TCP/IP host. Once the router determines that AutoInstall is not configured, it defaults to the setup facility. If the serial (WAN) cable is not connected, the router boots from Flash memory and go automatically into the setup facility.



Note You can run the setup facility any time you are at the enable prompt (#) by entering the command **setup**.

Configuring Global Parameters

When you first start the setup program, you must configure the global parameters. These parameters are used for controlling system-wide settings. Complete the following steps to enter the global parameters:

Step 1 Connect a console terminal to the console port on the I/O controller, and then boot the router.

The system boots from Flash memory. The following information appears after about 30 seconds. When you see this information, you have successfully booted your router:

```
Restricted Rights Legend
```

```
Use, duplication, or disclosure by the Government is
subject to restrictions as set forth in subparagraph
(c) of the Commercial Computer Software - Restricted
Rights clause at FAR sec. 52.227-19 and subparagraph
(c) (1) (ii) of the Rights in Technical Data and Computer
Software clause at DFARS sec. 252.227-7013.
```

```
cisco Systems, Inc.
170 West Tasman Drive
San Jose, California 95134-1706
```

```
Cisco Internetwork Operating System Software
IOS (tm) 7200 Software (C7200-J-M), Released Version 11.1(17)CA
Copyright (c) 1986-1996 by cisco Systems, Inc.
Compiled Sun 21-Apr-96 04:10 by
Image text-base: 0x60010890, data-base: 0x605F0000
```

```

ROM: System Bootstrap, Version 11.1(17)CA, RELEASED SOFTWARE
ROM: 7200 Software (C7200-J-M), Released Version 11.1(17)CA

router uptime is 8 minutes
System restarted by reload
System image file is "c7200-j-mz", booted via tftp from 10.1.10

cisco 7206 (NPE 150) processor with 12288K/4096K bytes of memory.
R4700 processor, Implementation 33, Revision 1.0 (Level 2 Cache)
Last reset from power-on
Bridging software.
SuperLAT software copyright 1990 by Meridian Technology Corp).
X.25 software, Version 2.0, NET2, BFE and GOSIP compliant.
TN3270 Emulation software (copyright 1994 by TGV Inc).
4 Ethernet/IEEE 802.3 interfaces.
5 FastEthernet/IEEE 802.3 interfaces.
8 Serial network interfaces.
125K bytes of non-volatile configuration memory.

20480K bytes of Flash PCMCIA card at slot 0 (Sector size 128K).
4096K bytes of Flash internal SIMM (Sector size 256K).
Configuration register is 0x0

```



Note The first two sections of the configuration script (the banner and the installed hardware) appear only at initial system startup. On subsequent uses of the setup command facility, the script begins with a System Configuration Dialog as shown in the following example.

```

--- System Configuration Dialog ---

At any point you may enter a questions mark '?' for help.
Use ctrl-c to abort configuration dialof at any prompt.
Default settings are in square brackets '['].

continue with configuration dialog? [yes]:

Step 2  When asked if you want to enter the initial configuration dialog and see the current interface summary,
enter yes or press Return:

Would you like to enter the initial configuration dialog? [yes]:

First, would you like to see the current interface summary? [yes]:

```

In the following example, the summary shows a Cisco 7206 at first-time startup; that is, nothing is configured.

Any interface listed with OK? value "NO" does not have a valid configuration.

Interface	IP-Address	OK?	Method	Status	Protocol
Ethernet0/0	unassigned	NO	not set	down	down
Ethernet0/1	unassigned	NO	not set	down	down

Step 3 Choose which protocols to support on your interfaces. For Internet Protocol (IP)-only installations, you can accept the default values for most of the questions. A typical configuration using IP, IPX, and AppleTalk follows and continues through [Step 9](#):

```

Configuring global parameters:

Enter host name [Router]:

```

Step 4 Enter the enable secret password and the enable password:

The enable secret password is a one-way cryptographic secret password used instead of the enable password when it exists.

```
Enter enable secret: barney
```

The enable password is used when there is no enable secret password and when using older software and some boot images.

```
Enter enable password: betty
```

Step 5 The Simple Network Management Protocol (SNMP) is the most widely supported open standard for network management. It provides a means to access and set configuration and run-time parameters of routers and communication servers. SNMP defines a set of functions that can be used to monitor and control network elements.

Enter **yes** to accept SNMP management; enter **no** to refuse it:

```
Configure SNMP Network Management? [yes]:  
Community string [public]:
```

Step 6 For the following query, do not enable CLNS:

```
Configure CLNS? [no]:
```

Step 7 For the following queries, enable routing on AppleTalk and IPX:

```
Configure AppleTalk? [no]: yes  
Multizone networks? [no]: yes
```

```
Configure IPX? [no]: yes
```

Step 8 For the following queries, do not enable Vines, XNS, DECnet, or bridging:

```
Configure Vines? [no]:  
Configure XNS? [no]:  
Configure DECnet? [no]:  
Configure bridging? [no]:
```

Step 9 In most cases you will use IP routing. If you are using IP routing, you must also select an interior routing protocol. You can specify only one of two interior routing protocols to operate on your system using the setup facility: Interior Gateway Routing Protocol (IGRP) or Routing Information Protocol (RIP).

To configure IP routing, enter **yes** (the default) or press **Return**, and then select an interior routing protocol:

```
Configure IP? [yes]:  
Configure IGRP routing? [yes]:  
Your IGRP autonomous system number [1]: 15
```

In the following example, routing is enabled on AppleTalk and IPX; IP is already selected:

```
Configure AppleTalk? [no]: yes  
Multizone networks? [no]: yes
```

```
Configure IPX? [no]: yes
```

The following sample display includes a continuous listing of all configuration parameters selected in [Step 3](#) through [Step 9](#). These parameters are shown in the order in which they appear on your console terminal. Only IP, IPX, and AppleTalk are the selected protocols for this example.

Configuring global parameters:

```
Enter host name [Router]: router
```

The enable secret is a one-way cryptographic secret used instead of the enable password when it exists.

```
Enter enable secret: barney
```

The enable password is used when there is no enable secret and when using older software and some boot images.

```
Enter enable password: betty
Enter virtual terminal password: fred
Configure SNMP Network Management? [yes]:
  Community string [public]:
Configure IP? [yes]:
  Configure IGRP routing? [yes]:
    Your IGRP autonomous system number [1]: 15
Configure Vines? [no]:
Configure IPX? [no]: y
Configure AppleTalk? [no]: y
  Multizone networks? [no]: y
Configure Apollo? [no]:
Configure DECnet? [no]:
Configure XNS? [no]:
Configure CLNS? [no]:
Configure bridging? [no]:
```

Step 10 Save your settings to NVRAM. (Refer to the [“Saving Your Settings to NVRAM”](#) section on page 4-10.)

Configuring Interfaces

Following are the steps for configuring interfaces to allow communication over a LAN or WAN. To configure the interface parameters, you need your interface network addresses and subnet mask information. Consult with your network administrator for this information.

Configuring Ethernet Interfaces

In the following example, the system is being configured for an Ethernet LAN using IP.

Step 1 Respond to the prompts as follows, using your own addresses and mask at the setup prompts:

```
Configuring interface parameters:
Configuring interface Ethernet0/0:
  Is this interface in use? [yes]:
  Use the 100 Base-TX (RJ-45) connector? [yes]:
  Configure IP on this interface? [no]: yes
    IP address for this interface: 10.1.1.10
    Number of bits in subnet field [0]:
    Class A network is 1.0.0.0, 0 subnet bits; mask is 255.0.0.0
```

Step 2 Determine if you are going to enable IPX on this interface; if you are, enter the unique IPX network number:

```
Configure IPX on this interface? [no]: yes
  IPX network number [2]:
```

- Step 3** If you will be using AppleTalk on the interface, enter **yes**. Enter **yes** to configure for extended AppleTalk networks, and then enter the cable range number. Enter the zone name and any other additional zones that are associated with your local zone:

```
Configure AppleTalk on this interface? [no]: yes
  Extended AppleTalk network? [no]: yes
  AppleTalk starting cable range [0]:
```

- Step 4** Save your settings to NVRAM. (Refer to the [“Saving Your Settings to NVRAM”](#) section on page 4-10.)
-



Note If additional Ethernet interfaces are available in your system, you are prompted for their configurations as well.

Configuring Synchronous Serial Interfaces

Synchronous serial interfaces are configured to allow connection to WANs through a CSU/DSU. Complete the following steps to configure the serial ports:

- Step 1** To configure serial port 0, enter **yes**:

```
Configuring interface Serial1/0:
  Is this interface in use? [no]: yes
```

- Step 2** Determine which protocols you want on the synchronous serial interface and enter the appropriate responses:

```
Configure IP unnumbered on this interface? [no]:
  IP address for this interface: 10.1.1.20
  Number of bits in subnet field [0]:
  Class A network is 1.0.0.0, 0 subnet bits; mask is 255.0.0.0

Configure IPX on this interface? [no]: yes
  IPX network number [2]:

Configure AppleTalk on this interface? [no]: yes
  Extended AppleTalk network? [no]:
  AppleTalk network number [1]:
```

- Step 3** Save your settings to NVRAM. (Refer to the [“Saving Your Settings to NVRAM”](#) section on page 4-10.)
-



Note If additional synchronous serial interfaces are available in your system, you are prompted for their configuration as well.

The following sample display includes a continuous listing of all interface configuration parameters selected for Ethernet and synchronous serial interfaces. These parameters are shown in the order in which they appear on your console terminal. Only one Ethernet and one synchronous serial interface are configured for this example.

Configuring interface parameters:

```
Configuring interface Ethernet0/0:
  Is this interface in use? [no]: yes
  Configure IP on this interface? [no]: yes
    IP address for this interface: 10.1.1.10
    Number of bits in subnet field [0]:
    Class A network is 1.0.0.0, 0 subnet bits; mask is 255.0.0.0
  Configure IPX on this interface? [no]: yes
    IPX network number [2]: 10
  Configure AppleTalk on this interface? [no]: yes
    Extended AppleTalk network? [no]: yes
    AppleTalk starting cable range [0]:
```

```
Configuring interface Serial1/0:
  Is this interface in use? [no]: yes
  Configure IP on this interface? [no]: yes
  Configure IP unnumbered on this interface? [no]:
    IP address for this interface: 10.1.1.20
    Number of bits in subnet field [0]:
    Class A network is 1.0.0.0, 0 subnet bits; mask is 255.0.0.0
  Configure IPX on this interface? [no]: yes
    IPX network number [2]:
  Configure AppleTalk on this interface? [no]: yes
    Extended AppleTalk network? [no]:
    AppleTalk network number [1]:
```

The following configuration command script was created:

```
hostname Router
enable secret 5 $1$u8z3$PMYY8em./8sszhzk78p/Y0
enable password wilma
line vty 0 4
password s
snmp-server community public
!
ip routing
no vines routing
ipx routing
appletalk routing
no apollo routing
no decnet routing
no xns routing
no clns routing
no bridge 1
! Turn off IPX to prevent network conflicts.
interface Ethernet0/0
no ipx network
!
interface Ethernet0/0
ip address 10.1.1.10 255.0.0.0
appletalk cable-range 0-0 0.0
appletalk discovery
no mop enabled
!
interface serial1/0
ip address 10.1.1.20 255.0.0.0
ip route-cache cbus
```

```
no keepalive
!
!
router igrp 15
network 1.0.0.0
!
end
```

Use this configuration? [yes/no]: **yes**
[OK]

Use the enabled mode 'configure' command to modify this configuration.

Press RETURN to get started!

Your Cisco 7206 is now minimally configured and is ready to use.

You can use the **setup** command if you want to modify the parameters after the initial configuration. To perform more complex configurations, use the **configure** command.

For information on additional interface configuration and specific system configurations, refer to the Preface, "[Related Documentation](#)" section on page xiv.

Configuring the Cisco 7206 Using Configuration Mode

You can configure the Cisco 7206 manually if you prefer not to use the setup facility or AutoInstall. Complete the following steps to configure the Cisco 7206 manually:

-
- Step 1** Connect a console terminal to the console port on the I/O controller.
- Step 2** When asked if you want to enter the initial dialog, answer **no** to go into the normal operating mode of the router:
- ```
Would you like to enter the initial dialog? [yes]: no
```
- Step 3** After a few seconds the user EXEC prompt (`Router>`) is displayed. Type **enable** to enter enable mode (configuration changes can only be made in enable mode):
- ```
Router> enable
```
- The prompt changes to the privileged EXEC prompt:
- ```
Router#
```
- Step 4** Enter the **config terminal** command at the enable prompt to enter configuration mode from the terminal:
- ```
Router# config terminal
Enter configuration commands, one per line. End with CNTL/Z.
Router(config)#
```
- At the `Router(config)#` prompt, enter the **interface** *type slot/port* command to enter interface configuration mode:
- ```
Router(config)# interface serial slot/port
Router(config-int)#
```
- In either configuration mode, you can now enter any changes to the configuration. Press **Ctrl-Z** (hold down the **Control** key while you press **Z**) or enter **end** to exit configuration mode and return to the EXEC command interpreter.

- Step 5 Save your settings to NVRAM. (Refer to the [“Saving Your Settings to NVRAM”](#) section on page 4-10.)
- 

Your Cisco 7206 is now minimally configured and will boot with the configuration you have entered. To see a list of the configuration commands available to you, enter `?` at the prompt or press the **help** key while in configuration mode.

## Saving Your Settings to NVRAM

To store the configuration or changes to your startup configuration in NVRAM, enter the **copy running-config startup-config** command at the `Hostname#` prompt:

```
Hostname# copy running-config startup-config
```

Using this command saves the configuration settings that you created in the Cisco 7206 using configuration mode and the setup facility. If you fail to do this, your configuration will be lost the next time you reload the router.

## Checking Your Settings and Reviewing Your Configuration Changes

You can check your settings and review any changes to your configuration by using various software commands.

To check the value of the settings you have entered, enter the **show running-config** command at the `Router#` prompt:

```
Router# show running-config
```

To review changes you make to the configuration, use the EXEC **show startup-config** command to display the information stored in NVRAM.

## Performing Other Configuration Tasks

To make advanced configuration changes after you establish the basic startup configuration for your Cisco 7206, refer to the publications listed in the Preface, [“Related Documentation”](#) section on page xiv. These publications contain additional information on using the **configure** command.

The configuration publications also provide information about the following tasks:

- Understanding and working with the user interface on your router
- Booting and rebooting the router
- Setting the configuration register
- Loading configuration files or system images using remote copy protocol (rcp) or Trivial File Transfer Protocol (TFTP)
- Reloading the operating system



## Performing a Complex Configuration

After you have installed the Cisco 7206 hardware, checked all external connections, turned on the system power, allowed the system to boot up, and minimally configured the system, you might need to perform more complex configurations, which are beyond the scope of this publication.

For specific information on system and interface configuration, refer to the publications listed in the Preface, [“Related Documentation” section on page xiv](#).





## Maintaining the Cisco 7206

---

This chapter describes basic maintenance procedures for the Cisco 7206. The procedures are presented in the following sections:

- [Viewing Your System Configuration, page 5-1](#)
- [Replacing a Port Adapter or Service Adapter, page 5-4](#)
- [Installing and Removing a Flash Memory Card, page 5-7](#)
- [Formatting a New Flash Memory Card, page 5-9](#)
- [Copying a Bootable Image onto a Flash Memory Card, page 5-10](#)
- [Copying Bootable Images between Flash Memory Cards, page 5-11](#)
- [Reformatting a Flash Memory Card, page 5-12](#)
- [Replacing or Recovering a Lost Password, page 5-14](#)



### Note

For procedures that explain the use of the Flash Disk, refer to the *Using the Flash Disk* document.

For procedures that explain how to replace main, Flash, and ROM monitor memory in Cisco 7200 series routers, refer to the *Memory Replacement Instructions for the Network Processing Engine or Network Services Engine and Input/Output Controller* document.

The preceding documents are available on Cisco.com.

---

## Viewing Your System Configuration

You can use the **show version** and the **show diag** commands to view information specific to the hardware configuration of your Cisco 7206.

Use the **show version** (or **show hardware**) command to display the system hardware (the network processing engine and the number of interfaces installed), the software version, the names and sources of configuration files, and the boot images.

The following example shows the output from the **show version** command:

```
Router> show version
Cisco Internetwork Operating System Software
IOS (tm) 7200 Software (C7200-J-M), Released Version 11.1(17)CA
Copyright (c) 1986-1996 by cisco Systems, Inc.
Compiled Sun 21-Apr-96 04:10 by
Image text-base: 0x60010890, data-base: 0x605F0000
```

```

ROM: System Bootstrap, Version 11.1(17)CA RELEASED SOFTWARE
ROM: 7200 Software (C7200-J-M), Released version 11.1(17)CA

router uptime is 8 minutes
System restarted by reload
System image file is "c7200-j-mz", booted via tftp from 1.1.10

cisco 7206 (NPE150) processor with 12288K/4096K bytes of memory.
R4700 processor, Implementation 33, Revision 1.0 (Level 2 Cache)
Last reset from power-on
Bridging software.
SuperLAT software copyright 1990 by Meridian Technology Corp).
X.25 software, Version 2.0, NET2, BFE and GOSIP compliant.
TN3270 Emulation software (copyright 1994 by TGV Inc).
4 Ethernet/IEEE 802.3 interfaces.
2 FastEthernet/IEEE 802.3 interfaces.
4 Token Ring/IEEE 802.5 interfaces.
12 Serial network interfaces
1 Compression port adapter
125K bytes of non-volatile configuration memory.
1024K bytes of packet SRAM memory.

20480K bytes of Flash PCMCIA card at slot 0 (Sector size 128K).
4096K bytes of Flash internal SIMM (Sector size 256K).
Configuration register is 0x0

```

Use the **show diag** command to determine what type of port adapters and I/O controller (with or without the Fast Ethernet port) are installed in slot 0 through slot 6 of your Cisco 7206. You can also use the **show diag slot** command to display information about a specific port adapter slot.

The following example shows the output from the **show diag** command. The I/O controller listed in slot 0 has the Fast Ethernet port that is equipped with an MII port and RJ-45 port:

```

Router> show diag

Slot 0:
Fast-ethernet on C7200 I/O with MII or RJ45 port adapter, 1 port
Port adapter is analyzed
Port adapter insertion time 1d18h ago
Hardware revision 2.0 Board revision A0
Serial number 3511336 Part number 73-1537-03
Test history 0x0 RMA number 00-00-00
EEPROM format version 1
EEPROM contents (hex):
 0x20: 01 14 02 00 00 35 94 28 49 06 01 03 00 00 00 00
 0x30: 50 00 00 00 FF FF FF FF FF FF FF FF FF FF FF FF

Slot 1:
Token-ring port adapter, 4 ports
Port adapter is analyzed
Port adapter insertion time 1d18h ago
Hardware revision 1.1 Board revision B0
Serial number 2825629 Part number 73-1390-04
Test history 0x0 RMA number 00-00-00
EEPROM format version 1
EEPROM contents (hex):
 0x20: 01 05 01 01 00 2B 1D 9D 49 05 6E 04 00 00 00 00
 0x30: 58 00 00 00 FF FF FF FF FF FF FF FF FF FF FF FF

```

```

Slot 2:
Fast-ethernet (TX-ISL) port adapter, 1 port
Port adapter is analyzed
Port adapter insertion time 1d18h ago
Hardware revision 1.0 Board revision A0
Serial number 3536481 Part number 73-1688-03
Test history 0x0 RMA number 00-00-00
EEPROM format version 1
EEPROM contents (hex):
 0x20: 01 11 01 00 00 35 F6 61 49 06 98 03 00 00 00 00
 0x30: 50 00 00 00 FF FF FF FF FF FF FF FF FF FF FF FF

Slot 3:
Serial port adapter, 4 ports
Port adapter is analyzed
Port adapter insertion time 1d18h ago
Hardware revision 1.0 Board revision UNKNOWN
Serial number 2824732 Part number 73-1389-04
Test history 0xFF RMA number 255-255-255
EEPROM format version 1
EEPROM contents (hex):
 0x20: 01 04 01 00 00 2B 1A 1C 49 05 6D 04 FF FF FF FF
 0x30: 02 FF FF FF FF FF FF FF FF FF FF FF FF FF FF FF

Slot 4:
Ethernet port adapter, 4 ports
Port adapter is analyzed
Port adapter insertion time 1d18h ago
Hardware revision 1.1 Board revision A0
Serial number 4294967295 Part number 73-1556-04
Test history 0x0 RMA number 00-00-00
EEPROM format version 1
EEPROM contents (hex):
 0x20: 01 02 01 01 FF FF FF FF 49 06 14 04 00 00 00 00
 0x30: 50 00 00 00 FF FF FF FF FF FF FF FF FF FF FF FF

Slot 5:
Compression engine 768K port adapter, 0 ports
Port adapter is analyzed
Port adapter insertion time 00:11:11 ago
Hardware revision 255.255 Board revision UNKNOWN
Serial number 4294967295 Part number 255-65535-255
Test history 0xFF RMA number 255-255-255
EEPROM format version 255
EEPROM contents (hex):
 0x20: FF 09 FF FF FF FF FF FF FF FF FF FF FF FF FF FF
 0x30: FF FF FF FF FF FF FF FF FF FF FF FF FF FF FF FF

Slot 6:
Mueslix serial (V.35) port adapter, 8 ports
Port adapter is analyzed
Port adapter insertion time 00:11:26 ago
Hardware revision 255.255 Board revision UNKNOWN
Serial number 4294967295 Part number 255-65535-255
Test history 0xFF RMA number 255-255-255
EEPROM format version 1
EEPROM contents (hex):
 0x20: 01 0D FF FF FF FF FF FF FF FF FF FF FF FF FF FF
 0x30: FF FF FF FF FF FF FF FF FF FF FF FF FF FF FF FF

```

For specific information on the **show version**, **show diag**, and other software commands, refer to the publications listed in the Preface, “[Related Documentation](#)” section on page xiv.

# Replacing a Port Adapter or Service Adapter

At some point, you might want or need to replace a port or service adapter in your Cisco 7206. The following procedures explain how to remove and install a port or service adapter. For software commands that display information about a specific port or service adapter, or for all port and service adapters installed in your Cisco 7206, refer to [Chapter 1, “Product Overview,”](#) the “[Port Adapter Slot and Logical Interface Numbering](#)” section on page 1-28.



Note

The steps for removing and installing a port or service adapter are the same; therefore, the term *adapter* in the following procedures applies to both port adapters and service adapters, unless noted otherwise.

## Removing a Port or Service Adapter

Complete the following steps to remove a port or service adapter from the Cisco 7206 router:

**Step 1** Attach an ESD-preventative wrist strap between you and an unfinished chassis surface.



Warning

During this procedure, wear grounding wrist straps to avoid ESD damage to the card. Do not directly touch the backplane with your hand or any metal tool, or you could shock yourself.

**Step 2** Place the port adapter lever for the desired port adapter slot in the unlocked position. The lever remains in the unlocked position. (Refer to [Figure 5-1](#).)

**Figure 5-1** Placing the Port Adapter Lever in the Unlocked Position

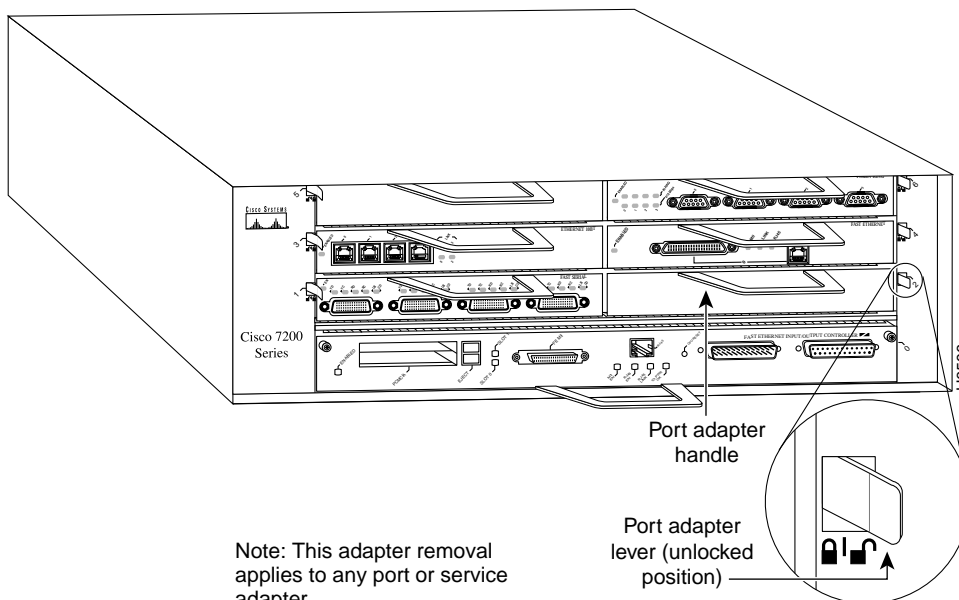

**Step 3** Grasp the handle on the port or service adapter and carefully pull the adapter from the midplane, about half way out of its slot. If you are removing a blank adapter or a service adapter, pull the blank or service adapter all the way out of the chassis slot and continue from Step 6.



**Note** As you pull a port adapter from the midplane, OIR administratively shuts down all active interfaces on the port adapter (service adapters do not have interfaces). For a complete description of OIR, refer to [Chapter 1, “Product Overview,”](#) the “[Online Insertion and Removal](#)” section on page 1-30.

- Step 4** With the port adapter half way out of the slot, disconnect all cables from the port adapter. (This step does not apply to service adapters.)
- Step 5** After disconnecting the cables, pull the port adapter from its chassis slot.



**Caution** Always handle the port or service adapter by the carrier edges and handle; never touch the adapter’s components or connector pins. (Refer to [Figure 5-2.](#))

**Figure 5-2 Port and Service Adapter Handling—Side View**

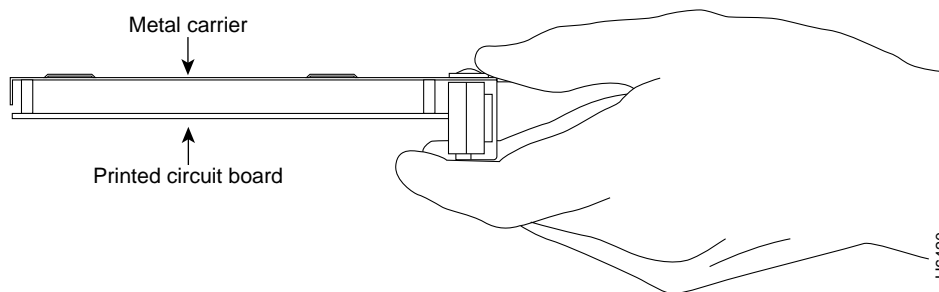

- Step 6** Place the adapter on an antistatic surface with its components facing upward, or in a static shielding bag. If the adapter will be returned to the factory, immediately place it in a static shielding bag.

This completes the procedure for removing a port or service adapter from the Cisco 7206 router.

## Installing a Port Adapter or Service Adapter

Complete the following steps to install a port or service adapter in the Cisco 7206 router:

- Step 1** Attach an ESD-preventative wrist strap between you and an unfinished chassis surface.



**Warning** During this procedure, wear grounding wrist straps to avoid ESD damage to the card. Do not directly touch the backplane with your hand or any metal tool, or you could shock yourself.

- Step 2** Use both hands to grasp the adapter by its metal carrier edges and position the adapter so that its components are downward. (See [Figure 5-2.](#))

**Figure 5-3** Aligning the Adapter Metal Carrier Between the Slot Guides

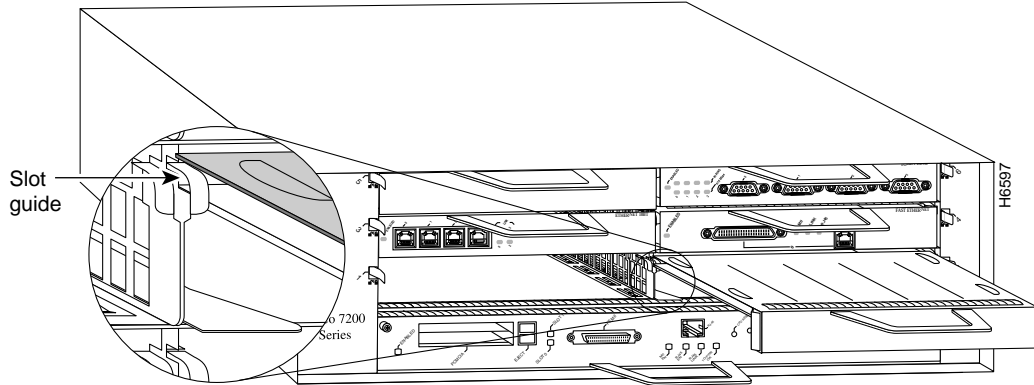

Note: This adapter alignment applies to any port or service adapter.

- Step 3** Align the left and right edge of the adapter's metal carrier between the guides in the port adapter slot. (Refer to [Figure 5-3](#).)
- Step 4** With the metal carrier aligned in the slot guides, gently slide the port adapter half way into the port adapter slot. If you are installing a service adapter, carefully slide the service adapter all the way into the slot until the adapter is seated in the router midplane and continue from Step 7.



**Caution**

Do not slide the port adapter all the way into the slot until you have connected all required cables. Attempting to do so will disrupt normal operation of the router.

- Step 5** With the port adapter half way in the slot, connect all required cables to the port adapter.



**Note**

For connection equipment, signaling, and pinout information for a specific port adapter type, refer to the configuration note for the port adapter. For example, connection equipment, signaling, and pinout information for the Fast Ethernet port adapter is contained in the configuration note *PA-FE-TX and PA-FE-FX Fast Ethernet 100BaseT Port Adapter Installation and Configuration*. This configuration note is available on Cisco.com.

- Step 6** After connecting the cables, carefully slide the port adapter all the way into the slot until the adapter is seated in the router midplane.



**Figure 5-4** Placing the Port Adapter Lever in the Locked Position

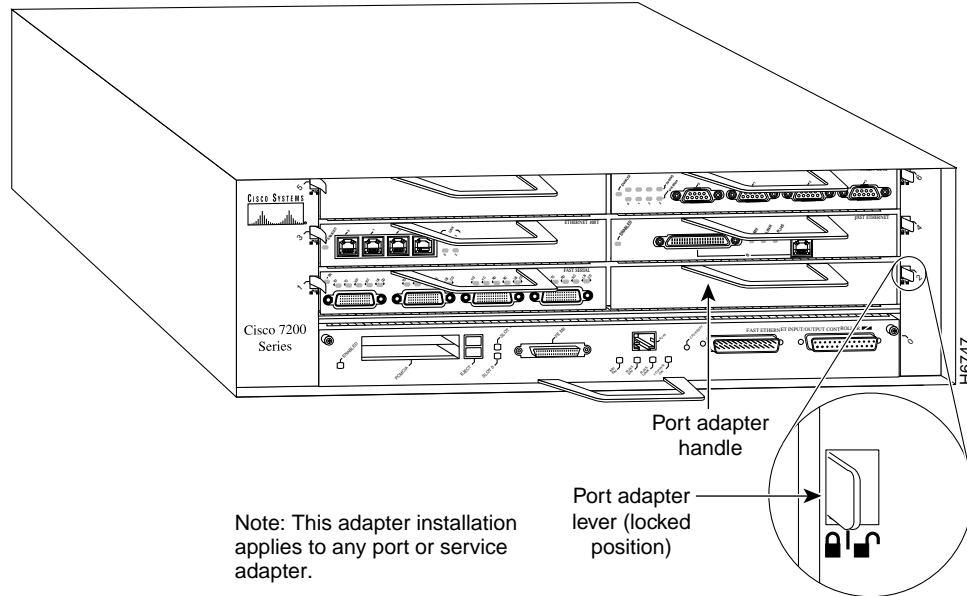

**Step 7** Move the port adapter lever to the locked position. (See [Figure 5-4](#).)



**Note** If the lever does not move to the locked position, the adapter is not completely seated in the midplane. Carefully pull the adapter half way out of the slot, reinsert it, and move the port adapter lever to the locked position.

This completes the procedure for installing a port or service adapter in the Cisco 7206 router.

## Installing and Removing a Flash Memory Card

The I/O controller has two PC Card slots for Flash memory cards: slot 0 (lower) and slot 1 (upper).

### Inserting a Flash Memory Card

Complete the following steps to insert a Flash memory card in either PC Card slot:



**Note**

To avoid potential problems when inserting spare Flash memory cards in your Cisco 7206, we recommend that you reformat all of your Flash memory cards on a Cisco 7206 running one of the recommended Cisco IOS software releases. The [“Reformatting a Flash Memory Card”](#) section on [page 5-12](#) contains instructions that explain how to reformat a Flash memory card.

Figure 5-5 Inserting and Removing a Flash Memory Card

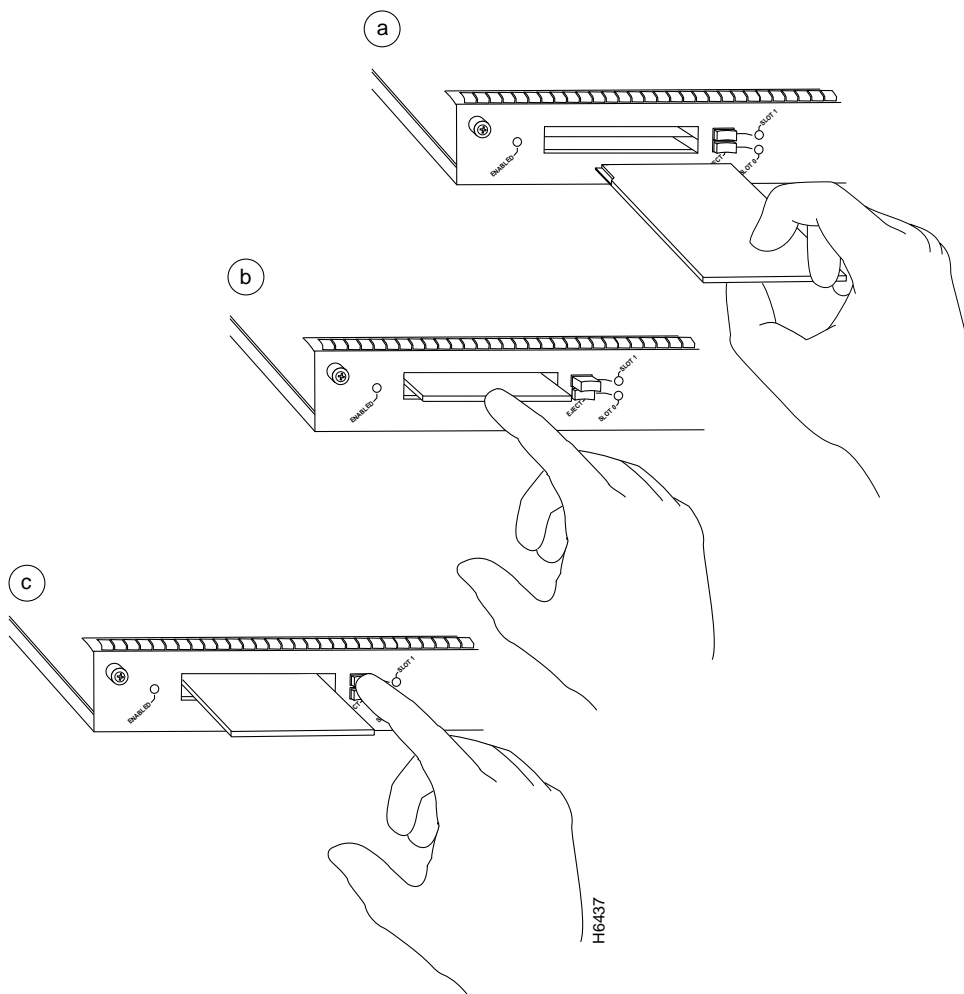

- 
- Step 1** Orient the Flash memory card so that its connector end faces the appropriate slot. (Refer to [Figure 5-5](#), step a.)
- Step 2** Carefully guide the card into the slot until the card seats in the slot's connector and the eject button for the slot pops out toward you. (Refer to [Figure 5-5](#), step b.)



---

**Note** Flash memory cards do not insert all the way into the PC Card slots; the end of the card protrudes from the I/O controller faceplate. Do *not* attempt to force the card past this point.

---

## Removing a Flash Memory Card

Complete the following steps to remove a Flash memory card from either PCMCIA slot:

- 
- Step 1 Press the ejector button on the slot. (Refer to [Figure 5-5](#), step c.)
  - Step 2 Grasp the card and pull it from the slot.
  - Step 3 Place the card in an antistatic bag.
- 

This completes the steps for inserting and removing a Flash memory card.

## Formatting a New Flash Memory Card

The Flash memory card that shipped with your Cisco 7206 contains the Cisco IOS software image you need to boot your router. In some cases, you might need to insert a new Flash memory card and copy images or backup configuration files onto it. Before you can use a new Flash memory card, you must format it. (Use only Intel Series 2+ Flash memory cards.)



### Note

To avoid potential problems when inserting spare Flash memory cards in your Cisco 7206, we recommend that you reformat all of your Flash memory cards on a Cisco 7206 running one of the recommended Cisco IOS software releases. The [“Reformatting a Flash Memory Card”](#) section on [page 5-12](#) contains instructions that explain how to reformat a Flash memory card.



### Caution

The following formatting procedure erases all information on the Flash memory card. To prevent the loss of important data that might be stored on a Flash memory card, proceed carefully. If you want to save the data on a Flash memory card, copy the data to a server before you format the card.



### Note

The following procedure assumes you have already booted your Cisco 7206.

Use the following procedure to format a new Flash memory card:

- 
- Step 1 Using the procedure in the [“Installing and Removing a Flash Memory Card”](#) section on [page 5-7](#) insert the Flash memory card into slot 0. (If slot 0 is not available, use slot 1.)
  - Step 2 Format the Flash memory card using the **format slot0:** (or **format slot1:**) command as follows.

```
Router# format slot0:
All sectors will be erased, proceed? [confirm]
Enter volume id (up to 30 characters): MyNewCard
Formatting sector 1
Format device slot0 completed
Router#
```

---

The new Flash memory card is now formatted and ready to use.

**Note**

For this example, an 8-MB Flash memory card was used, and at the line “Formatting sector,” the system counted the card’s sectors backwards from 64 to 1 as it formatted them. For 16-MB Flash memory cards, the system counts backward from 128 to 1, and for 20-MB Flash memory cards, the system counts backward from 160 to 1.

**Note**

For configuration information and descriptions of the commands used in this chapter, refer to the *Configuration Fundamentals Configuration Guide* and the *Configuration Fundamentals Command Reference*.

## Copying a Bootable Image onto a Flash Memory Card

Once you have formatted a new Flash memory card, you can copy a bootable image onto it. The copying procedure assumes the following:

- You have an I/O controller with a good image in the onboard Flash SIMM so you can start the Cisco 7206.
- The bootable image you want to copy to the Flash memory card exists on a TFTP server to which you have access (meaning you know its name and have connectivity to it), and at least one interface is available over which you can access this server.

**Note**

To ensure access to a TFTP sever, you will need to configure at least one network interface using the setup command facility. For instructions on using this procedure, refer to [Chapter 4, “Performing a Basic Configuration of the Cisco 7206,”](#) the “[Configuring the Cisco 7206 Manually Using the Setup Facility](#)” section on page 4-3.

- You know the filename of the image you want you want to copy onto the Flash memory card.

Following is the procedure for copying a bootable file (called `new.image` in the examples) onto the Flash memory card:

- 
- Step 1** Boot the Cisco 7206 and allow it to initialize.
- Step 2** Insert an unformatted Flash memory card into slot 0 (use slot 1 if slot 0 is not available) and format the card using the procedure in the “[Formatting a New Flash Memory Card](#)” section on page 5-9. Then proceed to Step 3.

**Note**

If you have already formatted a Flash memory card, you can use it instead; however, you cannot boot from a Flash memory card that was formatted on another type of system. You must reformat the card to use it as a boot source. To avoid potential problems when inserting spare Flash memory cards in your Cisco 7206, we recommend that you reformat all of your Flash memory cards on a Cisco 7206 running one of the recommended Cisco IOS software releases. The “[Reformatting a Flash Memory Card](#)” section on page 5-12 section later in this chapter contains instructions that explain how to reformat a Flash memory card.

- Step 3** Copy the new image (`new.image` in the following example) to the Flash memory card and make this image the default boot image. Then reboot the router using the following series of commands:



**Note**

The scenario assumes that the new image will fit on the Flash memory card in slot 0, alongside the old image. If there is not enough available space, use the **delete** command to delete files from the Flash memory card to make sufficient room for the new image; however, do *not* delete the *old.image* file. Then use the **squeeze** command to remove these deleted files from the Flash memory card. If, after you have deleted files and used the **squeeze** command, the two files cannot coexist on the Flash memory card in slot 0, remove this card (place it in an antistatic bag and store it in a safe place), and then insert the new Flash memory card (with the file *new.image*) in slot 0. Proceed to Step 5 and use the command **boot system flash slot0:new.image** to designate the file *new.image* as the default boot image.

**Step 1** Boot the Cisco 7206. By default, the file *boot.image* is used.

**Step 2** Enable the router as follows:

```
Router> en
Password:
Router#
```

**Step 3** Insert the new Flash memory card in slot 1.

**Step 4** Use the following command to copy the file *new.image* in slot 1 to the Flash memory card in slot 0, *only if* there is enough memory space for the two images to coexist. If there is not enough memory space, proceed to Step 5.

```
Router# copy slot1:new.image slot0:new.image
```



**Note** You can also enter the preceding command as **copy slot1:new.image slot0:**.

**Step 5** Use the following series of commands to designate the file *new.image* (which is on the Flash memory card in slot 0) as the default boot image:

```
Router# config t
Router(config)# no boot system
Router(config)# boot system flash slot0:new.image
Router(config)# ^z
Router# copy running-config startup-config
Router# reload
```

When the system reloads, it will boot the file *new.image* from the Flash memory card in slot 0.

This completes the procedure for copying bootable images between Flash memory cards.

## Reformatting a Flash Memory Card

Depending on the circumstances, you might need to use a Flash memory card from another system to copy images or backup configuration files; however, you cannot boot from a Flash memory card that was formatted on another type of system. You must reformat the card before you can use it as a boot source. (Use only Intel Series 2+ Flash memory cards.)

**Note**

To avoid potential problems when inserting spare Flash memory cards in your Cisco 7206, we recommend that you reformat all of your Flash memory cards on a Cisco 7206 running one of the recommended Cisco IOS software releases.

**Caution**

The following formatting procedure erases all information on the Flash memory card. To prevent the loss of important data that might be stored on a Flash memory card, proceed carefully. If you want to save the data on a Flash memory card, copy the data to a server before you format the card.

The reformatting procedure assumes the following:

- You have already booted your Cisco 7206.
- You have access to a TFTP server (meaning you know its name and have connectivity to it) and at least one interface is available over which you can access this server, or a secondary Flash memory card available in slot 0 or slot 1 onto which you can copy files.

**Note**

To ensure access to a TFTP sever, you will need to configure at least one network interface using the setup command facility. For instructions on using this procedure, refer to [Chapter 4, “Performing a Basic Configuration of the Cisco 7206,”](#) the “[Configuring Interfaces](#)” section on page 4-6.

- You know the filename of the image you want you want to copy to the TFTP server or onto the secondary Flash memory card.

Use the following procedure to reformat a Flash memory card:

- Step 1** Insert the Flash memory card into slot 0. (If slot 0 is not available, use slot 1.) (Refer to the [“Installing and Removing a Flash Memory Card”](#) section on page 5-7.”)
- Step 2** Copy all the files on the Flash memory card to a TFTP server or a secondary Flash memory card. The following example is for copying files to a TFTP server. Refer to the earlier section [“Copying a Bootable Image onto a Flash Memory Card”](#) section on page 5-10 for Flash memory card examples.
- ```
Router> en
Password:
Router#copy slot0:image.name tftp
Enter destination file name [image.name]: image.name
CCCCCCCCCCCCCCCCCCCCCCCCCCCCCCCCCCCCCCCCCCCCCCCCCCCCCCCCCCCC
CCCCCCCCCCCC
Address or name of remote host [tftp.server.name]? tftp.server.name
!!!!!!!!!!!!!!!!!!!!!!!!!!!!!!!!!!!!!!!!!!!!!!!!!!!!!!!!!!!!!!!!!!!!
!!!!!!!!!!!!
Router#
```
- Step 3** Reformat the Flash memory card using the **format slot0:** (or **format slot1:**) command as follows.
- ```
Router# format slot0:
All sectors will be erased, proceed? [confirm]
Enter volume id (up to 30 characters): MyNewCard
Formatting sector 1
Format device slot0 completed
Router#
```
- Step 4** Copy the files you saved to the TFTP server back to the Flash memory card as follows.

```

Router# copy tftp slot0
Enter source filename: image.name
20575008 bytes available on device slot0, proceed? [confirm]
address or name of remote host [tftp.server.name]? tftp.server.name
loading new.image from tftp.server.name (via Ethernet1/0):!!!!!!!
!!
!!
[OK - 7799951/15599616 bytes]
cc
cc
Router#

```

The Flash memory card is now reformatted and ready to use.

## Replacing or Recovering a Lost Password

This section describes how to recover a lost enable or console login password, and how to replace a lost enable secret password on your Cisco 7206 router.



### Note

It is possible to recover the enable or console login password. The enable secret password is encrypted, however, and must be replaced with a new enable secret password.

## Overview of the Password Recovery Procedure

Following is an overview of the steps in the password recovery procedure:

- Step 1 If you can log in to the router, enter the **show version** command to determine the existing configuration register value.
- Step 2 Press the **Break** key to get to the bootstrap program prompt (ROM monitor). You might need to reload the system image by power cycling the router.
- Step 3 Change the configuration register so the following functions are enabled:
  - a. Break
  - b. Ignore startup configuration
  - c. Boot from Flash memory



### Note

The key to recovering a lost password is to set the configuration register bit 6 (0x0040) so that the startup configuration (usually in NVRAM) is ignored. This allows you to log in without using a password and to display the startup configuration passwords.

- Step 4 Power cycle the router by turning power off and then back on.
- Step 5 Log in to the router and enter the privileged EXEC mode.
- Step 6 Enter the **show startup-config** command to display the passwords.



- Step 7** Recover or replace the displayed passwords.
- Step 8** Change the configuration register back to its original setting.



**Note** To recover a lost password if the Break function is disabled on the router, you must have physical access to the router.

## Details of the Password Recovery Procedure

Complete the following steps to recover or replace a lost enable, enable secret, or console login password:

- Step 1** Attach an ASCII terminal to the console port on your Cisco 7206.
- Step 2** Configure the terminal to operate at 9600 baud, 8 data bits, no parity, and 2 stop bits.
- Step 3** If you can log in to the router as a nonprivileged user, enter the **show version** command to display the existing configuration register value. Note the value for use later and proceed to [Step 6](#). If you cannot log in to the router at all, go to the next step.
- Step 4** Press the **Break** key or send a Break from the console terminal. If Break is enabled, the router enters the ROM monitor, indicated by the ROM monitor prompt (`rommon1>`). Proceed to Step 6. If Break is disabled, power cycle the router (turn the router off or unplug the power cord, and then restore power). Then proceed to Step 5.
- Step 5** Within 60 seconds of restoring the power to the router, press the **Break** key or send a Break. This action causes the router to enter the ROM monitor and display the ROM monitor prompt (`rommon1>`).
- Step 6** Set the configuration register using the configuration register utility; enter the **confreg** command at the ROM monitor prompt as follows:

```
rommon1> confreg
```

Answer **yes** to the enable “ignore system config info?” question and note the current configuration register settings.

- Step 7** Initialize the router by entering the **reset** command as follows:

```
rommon2> reset
```

The router initializes the configuration register that is set to 0x142, and the router boots the system image from Flash memory and enters the system configuration dialog (setup) as follows:

```
--- System Configuration Dialog ---
```

- Step 8** Enter **no** in response to the system configuration dialog prompts until the following message is displayed:

```
Press RETURN to get started!
```

- Step 9** Press **Return**. The user EXEC prompt is displayed as follows:

```
Router>
```

- Step 10** Enter the **enable** command to enter privileged EXEC mode. Then enter the **show startup-config** command to display the passwords in the configuration file as follows:

```
Router# show startup-config
```

- Step 11** Scan the configuration file display looking for the passwords (the enable passwords are usually near the beginning of the file, and the console login or user EXEC password is near the end). The passwords displayed will look something like this:

```
enable secret 5 1ORPP$s9syZt4uKn3SnpuLDrhuei
enable password 23skiddoo
.
.
line con 0
password onramp
```

The enable secret password is encrypted and cannot be recovered; it must be replaced. The enable and console login passwords may be encrypted or clear text. Proceed to the next step to replace an enable secret, console login, or enable password. If there is no enable secret password, note the enable and console login passwords, if they are not encrypted, and proceed to [Step 16](#).

**Caution**

*Do not* execute the next step unless you have determined you must change or replace the enable, enable secret, or console login passwords. Failure to follow the steps as shown may cause you to erase your router configuration.

- Step 12** Enter the **configure memory** command to load the startup configuration file into running memory. This action allows you to modify or replace passwords in the configuration.

```
Router# configure memory
```

- Step 13** Enter the privileged EXEC command **configure terminal** to enter configuration mode:

```
Hostname# configure terminal
```

- Step 14** Change all three passwords using the following commands:

```
Hostname(config)# enable secret newpassword1
Hostname(config)# enable password newpassword2
Hostname(config)# line con 0
Hostname(config-line)# password newpassword3
```

Change only the passwords necessary for your configuration. You can remove individual passwords by using the **no** form of the above commands. For example, entering the **no enable secret** command removes the enable secret password.

- Step 15** You must configure all interfaces to be *not* administratively shut down as follows:

```
Hostname(config)# interface fastethernet 0/0
Hostname(config-int)# no shutdown
```

Enter the equivalent commands for all interfaces that were originally configured. If you omit this step, all interfaces will be administratively shut down and unavailable when the router is restarted.

- Step 16** Use the **config-register** command to set the configuration register to the original value noted in Step 3 or Step 7, or to the factory default value 0x2102 as follows:

```
Hostname(config)# config-register 0x2102
```

- Step 17** Press **Ctrl-Z** (hold down the **Control** key while you press **Z**) or enter **end** to exit configuration mode and return to the EXEC command interpreter.

**Caution**

---

*Do not* execute the next step unless you have changed or replaced a password. If you skipped [Step 12](#) through [Step 15](#), skip to [Step 19](#). Failure to observe this caution will cause you to erase your router configuration file.

---

- Step 18** Enter the **copy running-config startup-config** command to save the new configuration to NVRAM.
- Step 19** Enter the **reload** command to reboot the router.
- Step 20** Log in to the router with the new or recovered passwords.
- 

This completes the steps for recovering or replacing a lost enable, enable secret, or console login password.





## Troubleshooting the Installation

---

Your Cisco 7206 router went through extensive testing before leaving the factory. However, if you encounter problems starting the router, use the information in this chapter to help isolate the cause of the problems. This chapter contains the following sections:

- [Contacting a Customer Service Representative, page 6-1](#)
- [Troubleshooting Overview, page 6-2](#)
- [Troubleshooting the Power Subsystem, page 6-5](#)
- [Troubleshooting the Processor Subsystem, page 6-6](#)
- [Troubleshooting the Cooling Subsystem, page 6-7](#)

The procedures in this chapter assume that you are troubleshooting the initial system startup, and that the Cisco 7206 is in the original factory configuration. If you have removed or replaced components or changed any default settings, the recommendations in this chapter might not apply. Make sure to review the safety warnings listed in the publication *Regulatory Compliance and Safety Information for the Cisco 7200 Series Routers* that accompanied your Cisco 7206 before using the troubleshooting procedures in this chapter.

### Contacting a Customer Service Representative

If you are unable to easily solve the problem, contact a customer service representative for assistance and further instructions. Provide the representative with the following information:

- Date you received the router
- Chassis serial number
- Type of software and release number
- Brief description of the problem you are having
- Brief explanation of the steps you have taken to isolate and resolve the problem
- Maintenance agreement or warranty information

[Figure 6-1](#) shows the general troubleshooting strategy described in this chapter. Refer to this chart, as necessary, to follow the steps to isolate problems to a specific subsystem; then resolve the problem if possible.

Figure 6-1 Troubleshooting Strategy for Startup Problems

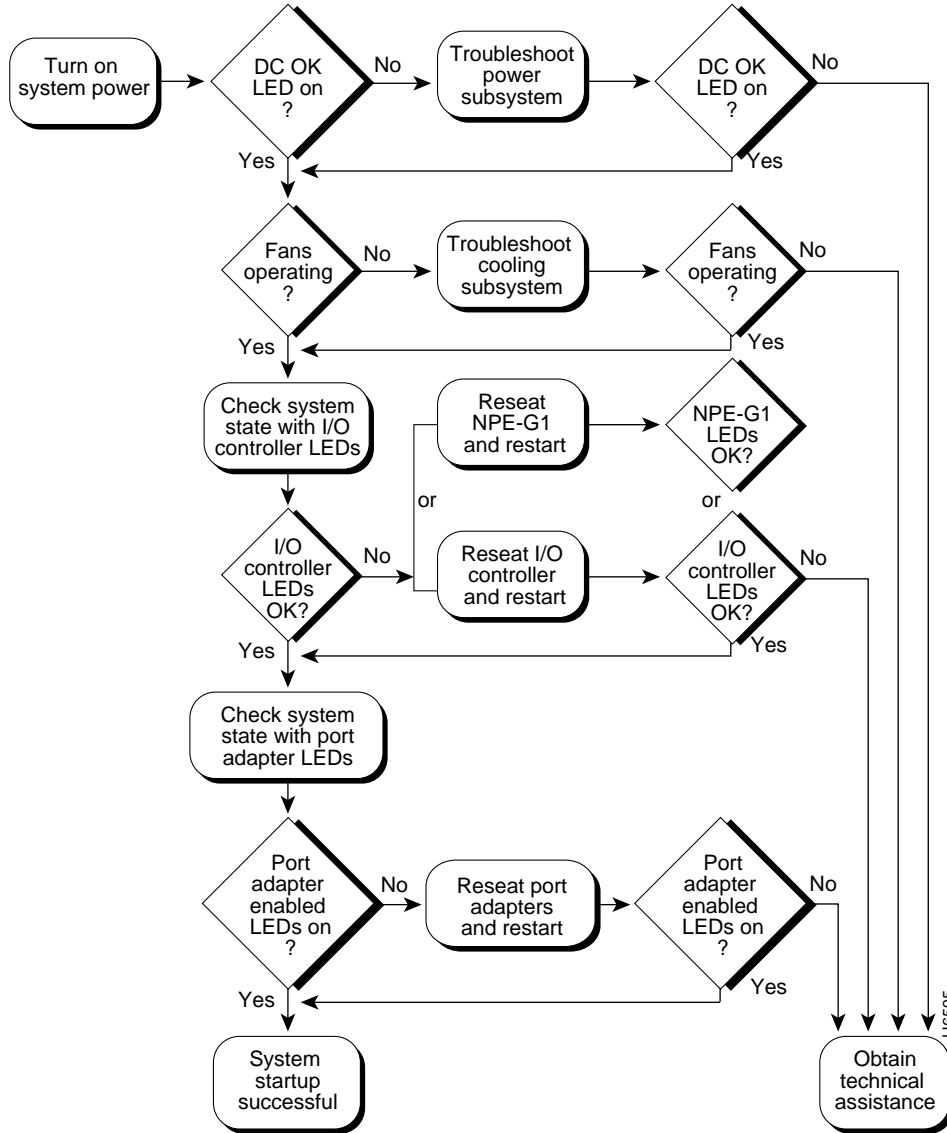

## Troubleshooting Overview

This section describes the troubleshooting methods used in this chapter and describes how the Cisco 7206 is divided into subsystems for more efficient problem solving.

## Using a Subsystems Approach to Problem Solving

The key to solving problems with the system is isolating the problem to a specific subsystem. The first step in solving startup problems is to compare what the system *is doing* to what it *should be doing*. Because a startup problem is usually caused by a single component, it is more efficient to first isolate the problem to a subsystem rather than troubleshoot each component in the system. For these troubleshooting procedures, consider the following subsystems:

- Power subsystem—This subsystem comprises the power supplies, the external power cable, and the midplane.
- Cooling subsystem—The chassis fan tray is the single component in this subsystem. The fans should be operating whenever system power is on. Replace the fan tray if you determine a fan is not functioning properly.
- Processor subsystem—This subsystem includes the I/O controller, network processing engine, and all port and service adapters. The system memory and management functions reside on the I/O controller and the network processing engine. The enabled LED on each port and service adapter indicates if the adapter is initialized. An adapter that is partially installed in the midplane can cause the system to hang and crash.

The following sections will help you isolate a problem to one of these subsystems and direct you to the appropriate troubleshooting section.

## Identifying Startup Problems

Startup problems are commonly due to the source power or to a board (network processing engine, I/O controller, or port or service adapter) that is dislodged from the midplane. Although an overtemperature condition is unlikely at initial startup, the environmental monitoring functions are included in this chapter because they also monitor internal voltages.

When you start up the Cisco 7206 for the first time, you should observe the startup sequence described in [Chapter 3, “Installing the Cisco 7206,”](#) the [“Starting the Cisco 7206”](#) section on page 3-24. This section contains a more detailed description of the normal startup sequence and describes the steps to take if the system does *not* perform that sequence as expected.

With the exception of the fan tray and network processing engine, LEDs indicate all system states in the startup sequence. By checking the state of the LEDs, you can determine when and where the system failed in the startup sequence. Use the following descriptions to isolate the problem to a subsystem, and then proceed to the appropriate sections to try to resolve the problem.

When you start up the system by turning on the power supply switch, the following should occur:

- You should immediately hear the fans operating. If not, proceed to the [“Troubleshooting the Cooling Subsystem”](#) section on page 6-7. If you determine that the power supply is functioning normally and that a fan is faulty, contact a customer service representative. If a fan does not function properly at initial startup, there are no installation adjustments that you should make.
- The power supply’s green power OK LED (at the rear of the chassis) should come on immediately when you place the power supply switch in the on (I) position, and remain on during normal system operation.

If the green power OK LED *does not* come on, proceed to the [“Troubleshooting the Power Subsystem”](#) section on page 6-5.

- The LEDs on the I/O controller should come on as follows:

- The IO POWER OK LED comes on immediately and indicates that the I/O controller is receiving DC power from the router midplane. This LED comes on during a successful router boot and remains on during normal operation of the router.

If this LED remains off when you start the router, either there is a problem with the power supply (it is damaged or not connected to the router midplane) or the network processing engine or the I/O controller is not connected to the router midplane. Proceed to the [“Troubleshooting the I/O Controller” section on page 6-6](#).

- The ENABLED LED comes on after the IO POWER OK LED and indicates that the network processing engine and the I/O controller are enabled for operation by the system; however, it does not mean that the Fast Ethernet port on the I/O controller is functional or enabled. This LED comes on during a successful router boot and remains on during normal operation of the router.

If this LED remains off when you start the router, it is probably a problem with the network processing engine or the I/O controller (they are damaged or not connected to the router midplane). Proceed to the [“Troubleshooting the I/O Controller” section on page 6-6](#).

- The FE ENABLE LED comes on after the ENABLED LED and indicates that the Fast Ethernet port on the I/O controller is initialized and enabled for operation by the system. This LED comes on during a successful router boot and remains on during normal operation of the router.

If this LED remains off when you start the router, it is probably a problem with the Fast Ethernet port on the I/O controller. Proceed to the [“Troubleshooting the I/O Controller” section on page 6-6](#).

**Note**

The I/O controller without the Fast Ethernet port does not have the FE ENABLE LED and the FE LINK LED. The I/O controller without the Fast Ethernet port and the I/O controller that is equipped with a single MII port do not have the MII EN, RJ-45 EN, and RJ-45 LINK LEDs.

- The FE LINK LED comes on only when the Fast Ethernet port on the I/O controller is receiving a carrier signal from the network. This LED remains off during normal operation of the router unless there is an incoming carrier signal, and does not indicate startup problems.

If this LED remains off when starting the router, it is probably a problem with the Fast Ethernet port on the I/O controller. Proceed to the [“Troubleshooting the I/O Controller” section on page 6-6](#).

- The MII EN LED comes on after the ENABLED LED and indicates that the Fast Ethernet port’s MII port is initialized and enabled for operation by the system, and configured for operation. This LED comes on during a successful router boot and after the MII port has been configured as the media type for the Fast Ethernet port (the RJ-45 port is the default media type for the Fast Ethernet port). This LED remains on during normal operation of the router.

If this LED remains off when starting the router, it is probably a problem with the Fast Ethernet port on the I/O controller. Proceed to the [“Troubleshooting the I/O Controller” section on page 6-6](#).

- The RJ-45 EN LED comes on after the ENABLED LED and indicates that the Fast Ethernet port’s RJ-45 port (the default media type for the Fast Ethernet port) is initialized and enabled for operation by the system. This LED comes on during a successful router boot and remains on during normal operation of the router.

If this LED remains off when starting the router, it is probably a problem with the Fast Ethernet port on the I/O controller. Proceed to the [“Troubleshooting the I/O Controller” section on page 6-6](#) section later in this chapter.



- The RJ-45 LINK LED comes on only when the Fast Ethernet’s RJ-45 port is receiving a carrier signal from the network. This LED remains off during normal operation of the router unless there is an incoming carrier signal, and does not indicate startup problems.

If this LED remains off when starting the router, it is probably a problem with the Fast Ethernet port on the I/O controller. Proceed to the [“Troubleshooting the I/O Controller” section on page 6-6](#).



---

**Note** An MII LINK LED is not provided on the I/O controller because the LED is provided on external transceivers that are required for connecting to the MII port on the I/O controller. Refer to [Chapter 3, “Installing the Cisco 7206,”](#) the [“Fast Ethernet Connection Equipment” section on page 3-16](#) for Fast Ethernet MII connection requirements.

---

- The SLOT 1 and SLOT 2 LEDs only come on when either PC Card slot is being accessed by the system. These LEDs remain off during normal operation of the router and do not indicate startup problems.
- The enabled LED on each port and service adapter comes on when the network processing engine completes its initialization of the adapter for operation. The enabled LED indicates that the adapter is receiving power and has been recognized by the network processing engine; it does not indicate the state of the individual interfaces on the port adapters (service adapters do not have interfaces). If an enabled LED fails to come on, proceed to the [“Troubleshooting the Port Adapter and Service Adapters” section on page 6-7](#).
- When all LEDs come on to indicate that the system has booted successfully, the initial system banner should be displayed on the console screen. If it is not displayed, refer to the [“Console and Auxiliary Port Connection Equipment” section on page 3-14](#) in [Chapter 3, “Installing the Cisco 7206”](#) to verify that the terminal is set correctly and that it is properly connected to the I/O controller’s console port.

## Troubleshooting the Power Subsystem

Check the following to help isolate a problem with the power subsystem:

- On the first power supply, is the power OK LED on?
  - If yes, the power source is good, and the power supply is functional.
  - If no, make sure the AC power cable is connected at both ends.
  - If no, make sure the circuit breaker controlling the DC power supply leads in the ON position.
  - If no, make sure the – V, +V, and ground leads are properly connected to the router.
  - If the power OK LED remains off, and the power switch is set correctly, suspect the power source or the power cable. Turn the switch off, connect the power cable to another power source, if available, and turn the switch back on. If the LED comes on, the problem is the first power source.
  - If the power OK LED fails to come on after you connect the power supply to a new power source, replace the power cord, and turn the switch back on. If the AC power (or input power) LED then comes on, return the first power cable for replacement.
  - If the LED still fails to come on when the power supply is connected to a different power source with a new power cable, the power supply is probably faulty. If a second power supply is available, install it in the other power supply bay and contact a service representative for further instructions.

- Is the power OK LED on for the second (redundant) power supply?
  - If yes, the power source is good and this power supply is functional. To continue with troubleshooting the process proceed to the [“Troubleshooting the Processor Subsystem” section on page 6-6](#).
  - If not, repeat each of the preceding procedures for the second power supply.



**Note** After powering off the router, wait at least 30 seconds before powering it on again.

If you are unable to resolve the problem or you determine that either a power supply or chassis connector is faulty, contact a service representative for instructions.

## Troubleshooting the Processor Subsystem

The processor subsystem comprises the I/O controller, network processing engine, and all port and service adapters. The I/O controller and network processing engine are required system components. The system cannot operate unless the I/O controller and network processing engine are installed properly; however, the system can operate without any port or service adapters installed as long as none are in *partial* contact with the midplane pins. A port or service adapter that is partially connected to the midplane sends incomplete signals to the processor, which faults the PCI bus and causes the system to hang. Therefore, first ensure that the I/O controller and the network processing engine are installed properly and the system software has initialized successfully. Then, if necessary, you can troubleshoot individual port and service adapters.

### Troubleshooting the I/O Controller

The procedures in this section assume that the I/O controller, network processing engine, and router itself are in the original factory configuration, and that you have not made changes to your configuration file.

If the I/O controller LEDs do not go on as expected (refer to the [“Identifying Startup Problems” section on page 6-3](#) section in this chapter), check the following items to help isolate the problem.

- Do all of the I/O controller LEDs remain off when the system power switch is turned on?
  - If the LEDs stay off, first refer to the sections [“Troubleshooting the Power Subsystem” section on page 6-5](#) and [“Troubleshooting the Cooling Subsystem” section on page 6-7](#) to ensure that both the fans and the power supply are functioning properly.
  - If the power supply and fans appear operational but none of the I/O controller LEDs are on, suspect that an improperly connected I/O controller or port adapter has hung the system. Tighten all captive installation screws, and then restart the system.
  - With the power supply turned off, reseal the I/O controller in its slot and restart the router.
- Is the I/O controller enabled LED on?
  - If yes, the system software has initialized successfully, and the system is operational.
  - If the enabled LED remains off, the system detected a processor hardware failure. (This LED should be on in normal operation.) Contact a service representative for instructions.

## Troubleshooting the Network Processing Engine

The procedures in this section assume that the I/O controller, network processing engine, and router itself are in the original factory configuration, and that you have not made changes to your configuration file.

If the I/O controller enabled LED does not go on as expected, make sure the power to the router is turned off, reseal the network processing engine in its slot, and restart the router.

If the enabled LED remains off, the system detected a processor hardware failure. (This LED should be on in normal operation.) Contact a service representative for instructions.

## Troubleshooting the Port Adapter and Service Adapters

Check the following to help isolate a problem with the port or service adapters:

- Are *all* adapter enabled LEDs on?  
If yes, the system is operational.
- Are *any* adapter enabled LEDs off?
  - If the enabled LED on an individual adapter is off, suspect that the adapter has pulled away from the midplane. Reseat the adapter in its slot (you do not have to turn off the system power when removing or replacing port or service adapters). After the system reinitializes the interfaces (if present—service adapters do not have interfaces), the enabled LED on the adapter should go on.
  - If the enabled LED remains off, the system detected a processor hardware failure. (This LED should be on in normal operation.) Contact a service representative for instructions.

## Troubleshooting the Cooling Subsystem

Check the following to help isolate a problem with the cooling system:

- When you start up the system, do the fans start operating?  
To determine if the fans are operating, listen for them. In noisy environments, place your hand on the left side of the chassis (when viewing the chassis from the front) to feel for air being forced out the vents.
  - If yes, the power to the fan tray is good.
  - If no, there is a problem with the fan tray or power. Refer to the “Troubleshooting the Power Subsystem” section in this chapter.
- The following message, if displayed, indicates that the system has detected an overtemperature condition or out-of-tolerance power condition inside the chassis.

```
Queued messages:
%ENVM-1-SHUTDOWN: Environmental Monitor initiated shutdown
```

If an environmental shutdown results from an out-of-tolerance power condition, the power OK LED will go off, and the system shuts down. (Refer to the [“Troubleshooting the Power Subsystem” section on page 6-5](#).) Although an overtemperature condition is unlikely at initial startup, ensure that heated exhaust air from other equipment is not entering the router’s inlet vent, and that there is sufficient clearance around the sides of the chassis to allow cooling air to flow. Refer to the [“Preventive Site Configuration: Maintaining Normal Operation” section on page 2-6 in Chapter 2](#), [“Preparing for Installation”](#) for preventive site configurations.

The above message could also indicate a faulty component or temperature sensor. Before the system shuts down, use the **show environment** or **show environment table** command to display the internal chassis environment. (Refer to the “[Functional Overview](#)” section in [Chapter 1](#), “[Product Overview](#)” for descriptions of the **show environment** and **show environment table** commands.)

If you experience trouble with the startup that is not resolved with these procedures, contact a service representative for assistance and further instructions.



## Industry-Standard Wiring Plans

When you install more than a few terminals, you face the problem of organizing the wiring. AT&T has devised a uniform scheme for dealing with large numbers of wires for the telephone industry. The scheme uses two color codes—one for large numbers of wires organized in pairs and the other for smaller numbers of wires that may also be organized in pairs. We recommend the use of this wiring scheme whenever possible.

For large numbers of wires, each pair is assigned a two-color code. The colors are selected from two groups of five, resulting in what is called a *binder-group* of 25 pairs. The colors used for a group are white, red, black, yellow, and violet. The colors used for “pair within group” are blue, orange, green, brown, and slate.

Each pair must have a unique color combination. One wire within each pair has a solid background of its group color and stripes of the “pair within group” color; the second wire has the colors reversed. [Table A-1](#) lists the sequences. Note that red-brown and red-orange wires can be easily confused.

**Table A-1 Telephone Industry 25-Pair Color Code and Pin Numbers**

| Pair Number | Wire Number | Solid Color | Stripe Color | Pin Number |
|-------------|-------------|-------------|--------------|------------|
| 1           | 1           | White       | Blue         | 26         |
| 1           | 2           | Blue        | White        | 1          |
| 2           | 1           | White       | Orange       | 27         |
| 2           | 2           | Orange      | White        | 2          |
| 3           | 1           | White       | Green        | 28         |
| 3           | 2           | Green       | White        | 3          |
| 4           | 1           | White       | Brown        | 29         |
| 4           | 2           | Brown       | White        | 4          |
| 5           | 1           | White       | Slate        | 30         |
| 5           | 2           | Slate       | White        | 5          |
| 6           | 1           | Red         | Blue         | 31         |
| 6           | 2           | Blue        | Red          | 6          |
| 7           | 1           | Red         | Orange       | 32         |
| 7           | 2           | Orange      | Red          | 7          |
| 8           | 1           | Red         | Green        | 33         |
| 8           | 2           | Green       | Red          | 8          |

**Table A-1 Telephone Industry 25-Pair Color Code and Pin Numbers (continued)**

| Pair Number | Wire Number | Solid Color | Stripe Color | Pin Number |
|-------------|-------------|-------------|--------------|------------|
| 9           | 1           | Red         | Brown        | 34         |
| 9           | 2           | Brown       | Red          | 9          |
| 10          | 1           | Red         | Slate        | 35         |
| 10          | 2           | Slate       | Red          | 10         |
| 11          | 1           | Black       | Blue         | 36         |
| 11          | 2           | Blue        | Black        | 11         |
| 12          | 1           | Black       | Orange       | 37         |
| 12          | 2           | Orange      | Black        | 12         |
| 13          | 1           | Black       | Green        | 38         |
| 13          | 2           | Green       | Black        | 13         |
| 14          | 1           | Black       | Brown        | 39         |
| 14          | 2           | Brown       | Black        | 14         |
| 15          | 1           | Black       | Slate        | 40         |
| 15          | 2           | Slate       | Black        | 15         |
| 16          | 1           | Yellow      | Blue         | 41         |
| 16          | 2           | Blue        | Yellow       | 16         |
| 17          | 1           | Yellow      | Orange       | 42         |
| 17          | 2           | Orange      | Yellow       | 17         |
| 18          | 1           | Yellow      | Green        | 43         |
| 18          | 2           | Green       | Yellow       | 18         |
| 19          | 1           | Yellow      | Brown        | 44         |
| 19          | 2           | Brown       | Yellow       | 19         |
| 20          | 1           | Yellow      | Slate        | 45         |
| 20          | 2           | Slate       | Yellow       | 20         |
| 21          | 1           | Violet      | Blue         | 46         |
| 21          | 2           | Blue        | Violet       | 21         |
| 22          | 1           | Violet      | Orange       | 47         |
| 22          | 2           | Orange      | Violet       | 22         |
| 23          | 1           | Violet      | Green        | 48         |
| 23          | 2           | Green       | Violet       | 23         |
| 24          | 1           | Violet      | Brown        | 49         |
| 24          | 2           | Brown       | Violet       | 24         |
| 25          | 1           | Violet      | Slate        | 50         |
| 25          | 2           | Slate       | Violet       | 25         |

Cables with more than 25 pairs of wires are constructed from 25-pair groups. Very large cables have other variations generally not encountered inside terminal wire plants.

For smaller numbers of wires, such as wires for an individual telephone station or terminal, you may use a second color-code scheme. [Table A-2](#) lists this color code and the usual correspondence with the paired-wire color code. The alternate color code is included because sometimes the station wire uses the first three pairs of the standard color code (white-blue, blue-white, and so on), while other times it uses the six alternate colored wires.

**Table A-2** *Second Color-Code Scheme for Smaller Numbers of Wires*

| Pair Number | Wire Number | Solid Color | Stripe Color | Alternate Color | Pin Number |
|-------------|-------------|-------------|--------------|-----------------|------------|
| 1           | 1           | White       | Blue         | Green           | 4          |
| 1           | 2           | Blue        | White        | Red             | 3          |
| 2           | 1           | White       | Orange       | Black           | 2          |
| 2           | 2           | Orange      | White        | Yellow          | 5          |
| 3           | 1           | White       | Green        | White           | 1          |
| 3           | 2           | Green       | White        | Blue            | 6          |







## Configuration Register Information

The following information is found in this appendix:

- [Configuration Bit Meanings, page B-1](#)
- [Displaying the Configuration Register While Running Cisco IOS, page B-5](#)
- [Displaying the Configuration Register While Running ROM Monitor, page B-5](#)
- [Setting the Configuration Register While Running Cisco IOS, page B-6](#)
- [Setting the Configuration Register While Running ROM Monitor, page B-6](#)

## Configuration Bit Meanings

Use the processor configuration register information contained in this appendix to do the following:

- Set and display the configuration register value
- Force the system into the bootstrap program
- Select a boot source and default boot filename
- Enable or disable the Break function
- Control broadcast addresses
- Set the console terminal baud rate
- Load operating software from ROM
- Enable booting from a Trivial File Transfer Protocol (TFTP) server

[Table B-1](#) lists the meaning of each of the configuration memory bits. Following the table is a more in-depth description of each setting.

**Table B-1** Configuration Register Bit Settings

| Bit No. | Hex           | Meaning                                                                                |
|---------|---------------|----------------------------------------------------------------------------------------|
| 00–03   | 0x0000–0x000F | Boot field                                                                             |
| 06      | 0x0040        | Causes the system software to ignore nonvolatile random-access memory (NVRAM) contents |
| 07      | 0x0080        | OEM (original equipment manufacturer) bit enabled                                      |
| 08      | 0x0100        | Break disabled                                                                         |
| 10      | 0x0400        | IP broadcast with all zeros                                                            |

*(DRAFT LABEL) ALPHA DRAFT - CISCO CONFIDENTIAL***Table B-1 Configuration Register Bit Settings (continued)**

| Bit No. | Hex          | Meaning                                                |
|---------|--------------|--------------------------------------------------------|
| 11–12   | 0x800–0x1000 | Console line speed                                     |
| 13      | 0x2000       | Boots default ROM software if initial boot fails       |
| 14      | 0x4000       | IP broadcasts do not have network numbers              |
| 15      | 0x8000       | Enables diagnostic messages and ignores NVRAM contents |

**Bits 0–3**

The lowest four bits of the processor configuration register (bits 3, 2, 1, and 0) form the boot field. [Table B-2](#) provides information about the bits settings.

**Table B-2 Bits 0–3 Settings**

| Boot Field | Meaning                                                                       |
|------------|-------------------------------------------------------------------------------|
| 0          | Stays at the system bootstrap prompt (ROM monitor) on a reload or power cycle |
| 1          | Boots the boot helper image as a system image                                 |
| 2          | Full boot process, which loads the Cisco IOS image into Flash memory          |
| 2-F        | Specifies a default filename for booting over the network from a TFTP server  |

The boot field specifies a number in binary. If you set the boot field value to 0, you must have a console port access to boot the operating system manually. Boot the operating system by entering the **b** command at the bootstrap prompt as follows:

```
> b [tftp] flash filename
```

Definitions of the various command options follow:

- b**—Boots the default system software from ROM
- b flash**—Boots the first file in Flash memory
- b filename [host]**—Boots over the network using TFTP
- b flash filename**—Boots the file (*filename*) from Flash memory

If you set the boot field value to a value of 2 through F, and there is a valid system boot command stored in the configuration file, the router boots the system software as directed by that value. (See [Table B-3](#).) If you set the boot field to any other bit pattern, the router uses the resulting number to form a default boot filename for netbooting.

If there are no **boot** commands in the configuration file, the router attempts to boot the first file in system Flash memory. If no file is found in system Flash memory, the router attempts to netboot a default file with a name derived from the value of the boot field (for example, cisco2-7200). If the netboot attempt fails, the boot helper image in boot flash memory will boot up.

If **boot** commands are in the configuration file, the router software processes each **boot** command in sequence until the process is successful or the end of the list is reached. If the end of the list is reached without a file being successfully booted, the router will retry the **netboot** commands up to six times if bit 13 of the configuration register is set, otherwise it will load the operating system software available

*(DRAFT LABEL) ALPHA DRAFT - CISCO CONFIDENTIAL*

in ROMmon. If bit 13 is not set, the router will continue to netboot images indefinitely. The default setting for bit 13 is 0. If bit 13 is set, the system boots the boot helper image found in boot flash memory without any retries.

The server creates a default filename as part of the automatic configuration processes. To form the boot filename, the server starts with Cisco and links the octal equivalent of the boot field number, a dash, and the image name. [Table B-3](#) lists the default boot filenames or actions.



Note

A **boot system configuration** command in the router configuration in NVRAM overrides the default netboot filename.

**Table B-3** Default Boot Filenames

| Action/File Name       | Bit 3 | Bit 2 | Bit 1 | Bit 0 |
|------------------------|-------|-------|-------|-------|
| Bootstrap mode         | 0     | 0     | 0     | 0     |
| ROM software           | 0     | 0     | 0     | 1     |
| Flash software         | 0     | 0     | 1     | 0     |
| cisco3-<image-name1>   | 0     | 0     | 1     | 1     |
| cisco4-<image-name2>   | 0     | 1     | 0     | 0     |
| cisco5-<image-name3>   | 0     | 1     | 0     | 1     |
| cisco6-<image-name4>   | 0     | 1     | 1     | 0     |
| cisco7-<image-name5>   | 0     | 1     | 1     | 1     |
| cisco10-<image-name6>  | 1     | 0     | 0     | 0     |
| cisco11-<image-name7>  | 1     | 0     | 0     | 1     |
| cisco12-<image-name8>  | 1     | 0     | 1     | 0     |
| cisco13-<image-name9>  | 1     | 0     | 1     | 1     |
| cisco14-<image-name10> | 1     | 1     | 0     | 0     |
| cisco15-<image-name11> | 1     | 1     | 0     | 1     |
| cisco16-<image-name12> | 1     | 1     | 1     | 0     |
| cisco17-<image-name13> | 1     | 1     | 1     | 1     |

## Bit 6

Bit 6 causes the system software to ignore nonvolatile random-access memory (NVRAM) contents.

## Bit 7

Bit 7 enables the OEM bit. It disables the bootstrap messages at startup.

*(DRAFT LABEL) ALPHA DRAFT - CISCO CONFIDENTIAL*

## Bit 8

Bit 8 controls the console Break key. Setting bit 8 (the factory default) causes the processor to ignore the console Break key. Clearing bit 8 causes the processor to interpret Break as a command to force the system into the bootstrap monitor, halting normal operation. A Break can be sent in the first sixty seconds while the system reboots, regardless of the configuration settings.

## Bit 10 and Bit 14

Bit 10 controls the host portion of the Internet IP broadcast address. Setting bit 10 causes the processor to use all zeros; clearing bit 10 (the factory default) causes the processor to use all ones. Bit 10 interacts with bit 14, which controls the network and subnet portions of the IP broadcast address. [Table B-4](#) shows the combined effect of bit 10 and bit 14.

**Table B-4** *Bit 10 and Bit 14 Settings*

| Bit 14 | Bit 10 | IP Address (<net> <host>) |
|--------|--------|---------------------------|
| Off    | Off    | <ones><ones>              |
| Off    | On     | <zeros><zeros>            |
| On     | On     | <net><zeros>              |
| On     | Off    | <net><ones>               |

## Bit 11 and Bit 12

Bit 11 and Bit 12 in the configuration register determine the baud rate of the console terminal. [Table B-5](#) shows the bit settings for the four available baud rates. (The factory set default baud rate is 9600.)

**Table B-5** *Bit 11 and Bit 12 Settings*

| Baud | Bit 12 | Bit 11 |
|------|--------|--------|
| 9600 | 0      | 0      |
| 4800 | 0      | 1      |
| 2400 | 1      | 1      |
| 1200 | 1      | 0      |

## Bit 13

Bit 13 determines the server response to a bootload failure. If **boot** commands are in the configuration file, the router software processes each **boot** command in sequence until the process is successful or the end of the list is reached. If the end of the list is reached without a file being successfully booted, the router will retry the **netboot** commands up to six times if bit 13 of the configuration register is set, otherwise it will load the operating system software available in ROMmon. If bit 13 is not set, the router will continue to netboot images indefinitely. The default setting for bit 13 is 0. If bit 13 is set, the system boots the boot helper image found in boot flash memory without any retries.

*(DRAFT LABEL) ALPHA DRAFT - CISCO CONFIDENTIAL*

## Bit 15

Bit 15 enables diagnostic messages and ignores NVRAM contents.

# Displaying the Configuration Register While Running Cisco IOS

The configuration register can be viewed by using the **show version** or **show hardware** command.

The following is sample output of the **show version** command:

```

Router# show version
Cisco Internetwork Operating System Software
IOS (tm) 7200 Software (C7200-J-M), Version 11.1(9)CA1
Copyright (c) 1986-1996 by cisco Systems, Inc.
Compiled Sun 04-Aug-96 06:00 by biff
Image text-base: 0x600088A0, data-base: 0x605A4000
ROM: System Bootstrap, Version 11.1(5) RELEASED SOFTWARE
ROM: 7200 Software (C7200-BOOT-M), RELEASED SOFTWARE 11.1(9)CA1
Router uptime is 4 hours, 22 minutes
System restarted by reload
System image file is "c7200-j-mz", booted via slot0
cisco 7206 (NPE150) processor with 12288K/4096K bytes of memory.
R4700 processor, Implementation 33, Revision 1.0 (Level 2 Cache)

Last reset from power-on
Bridging software.
X.25 software, Version 2.0, NET2, BFE and GOSIP compliant.
Basic Rate ISDN software, version 1.0.
Chassis Interface.
12 Ethernet/IEEE 802.3 interfaces.
1 FastEthernet/IEEE 802.3 interface.
4 ISDN Basic Rate interfaces.
1 Compression port adapter.
Integrated NTIs for 4 ISDN Basic Rate interfaces
125K bytes of non-volatile configuration memory.
1024K bytes of packet SRAM memory.

20480K bytes of Flash PCMCIA card at slot 0 (Sector size 128K).
8192K bytes of Flash internal SIMM (Sector size 256K).
Configuration register is 0x2

```

# Displaying the Configuration Register While Running ROM Monitor

If the bootstrap prompt ">", the **o** command displays the virtual configuration register currently in effect. It includes a description of the bits. See the following sample output:

```

>o
Configuration register + 02x100 at last boot
Bit# Configuration register option settings:
15 Diagnostic mode disabled
14 IP broadcasts do not have network numbers
13 Boot default ROM software if network boot fails
12-11 Console speed is 9600 baud
10 IP broadcasts with ones

```

*(DRAFT LABEL) ALPHA DRAFT - CISCO CONFIDENTIAL*

```

09 Do not use secondary bootstrap
08 Break disabled
07 OEM disabled
06 Ignore configuration disabled
05 Fast boot disabled
04 Fan boot disabled
03-00 Boot to ROM monitor

```

If the prompt is “rommon1”, the **confreg** command displays the virtual configuration register currently in effect. It includes a description of the bits. See the following sample output:

```

rommon 1 > confreg

Configuration Summary
enabled are:
load rom after netboot fails
console baud: 9600
boot: the ROM Monitor

Do you wish to change the configuration? y/n [n]

```

## Setting the Configuration Register While Running Cisco IOS

The configuration register can be set in the configuration mode with the **config-register 0x<value>** command. See the following sample output:

```

Router# config t
Enter configuration commands, one per line. End with CNTRL/Z.
Router(config)#config-register 0x2142
Router(config)#end
Router#
%SYS-5-CONFIG_I: Configured from console by console

```

## Setting the Configuration Register While Running ROM Monitor

If the prompt is “>”, the **or0x<value>** command sets the configuration register. See the following sample output:

```

>o/r 0x2102
>

```

If the prompt is “rommon1”, the **confreg** command sets the configuration register. It prompts the user about each bit. See the following sample output:

```

rommon 1 > confreg

Confiuration Summary
enabled are:
load rom after netboot fails
console baud: 9600
boot: the ROM Monitor

do you wish to change the configuration y/n [n]: y
enable "diagnostic mode"? y/n [n]: n
enable "use net in IP bcast address"? y/n [n]: n
disable "use rom after netboot fails"? y/n [n]: n
enable "use all zero broadcast"? y/n [n]: n
enable "break/abort has effect"? y/n [n]: n

```

*(DRAFT LABEL) ALPHA DRAFT - CISCO CONFIDENTIAL*

```
enable "ignore system config info"? y/n [n]: n
change console baud rate? y/n [n]: n
change the boot characteristics? y/n [n]:y
enter to boot:
0 = ROM Monitor
1 = the boot helper image
2 - 15 = boot system
[0]: 2

Configuration Summary:
enabled are:
load rom after netboot fails
console baud: 9600
boot: image sepcified by the boot system commands or default to: cisco2-c7200

do you wish to change the configuration? y/n [n] n

You must reset or power cycle for new config to take effect
rommon 2 >
```

*(DRAFT LABEL) ALPHA DRAFT - CISCO CONFIDENTIAL*





---

## A

addresses, MAC [1-30](#)

air

exhaust [1-33](#)

flow [2-7](#)

AppleTalk, configuring [4-5](#)

AutoInstall configuration, basic [4-2](#)

---

## B

banner, system [3-24](#)

boot system flash command [5-12](#)

---

## C

cables

AC power [1-24](#)

interference [2-2](#)

swapping power [6-5](#)

caution

chassis, overheating [2-5](#)

data loss due to formatting Flash memory card [5-9, 5-13](#)

description [ix](#)

DRAM errors [1-12](#)

I/O controller removal while system operating [1-30](#)

network processing engine removal while system operating [1-30](#)

cautions

captive installation screws [2-1](#)

changes, reviewing configuration [4-10](#)

chassis

clearance [1-33](#)

footprint [2-5](#)

ground receptacles [1-4](#)

lifting [3-9](#)

physical description [1-26](#)

rack-mounting [3-2](#)

checklist, installation [2-10](#)

Cisco IOS requirements [1-6](#)

clearance

chassis [1-33](#)

commands

boot system flash [5-12](#)

config terminal [4-9](#)

configure [4-9](#)

copy [5-10, 5-12](#)

copy running-config startup-config [4-3, 4-10](#)

enable [4-9](#)

enable password [4-1](#)

enable secret [4-1](#)

full-duplex [1-23](#)

media-type [1-23](#)

setup [4-3](#)

show diag [1-22, 5-1](#)

show environment [1-33, 2-8](#)

show environment table [1-34](#)

show interfaces [1-29](#)

show running-config [4-10](#)

show startup-config [4-10](#)

show version [1-13, 5-1](#)

config terminal command [4-9](#)

configuration

file, saving [4-9, 4-10](#)

interface [4-6](#)

modifications [4-10](#)

- reviewing modifications [4-10](#)
- configuration bit meanings [B-1](#)
- configuration modes, basic [4-9](#)
- configuration procedures
  - AutoInstall [4-2](#)
  - basic router configuration [4-2](#)
  - Ethernet interface configuration [4-6](#)
  - I/O controller Fast Ethernet full-duplex configuration [1-23](#)
  - I/O controller Fast Ethernet media type configuration [1-23](#)
  - setup command facility [4-3](#)
  - synchronous serial interface configuration [4-7](#)
- configuration register [B-1](#)
- configure command [4-9](#)
- configuring
  - AppleTalk [4-5](#)
  - global parameters
    - description [4-3](#)
    - procedure [4-4](#)
    - sample configuration [4-6](#)
  - interface parameters
    - examples of [4-6, 4-7](#)
    - sample configuration [4-8 to 4-9](#)
  - interfaces [4-6](#)
  - IPX [4-5](#)
  - router
    - using AutoInstall [4-2](#)
    - using configuration mode [4-9](#)
    - using the setup command facility [4-3](#)
- configuring global parameters [4-3](#)
- connecting power [3-20](#)
- connection equipment
  - auxiliary port signals [3-16](#)
  - console and auxiliary [3-14](#)
  - console port signals [3-15](#)
  - Fast Ethernet MII and RJ-45 on I/O controller [3-16](#)
- connector
  - auxiliary port [3-16](#)

- console port [3-15](#)
- console terminal, system banner display [6-5](#)
- cooling subsystem [6-3, 6-7](#)
- copy command [5-10](#)
- copy command (Flash memory) [5-12](#)
- copy running-config startup-config command [4-3, 4-10](#)
- critical status level, environmental monitor [1-32](#)
- crossover cable, RJ-45 receptacle on I/O controller [3-19](#)

---

## D

- damage from overheating [1-31](#)
- DC power
  - shutdown [1-32](#)
- displays, environmental [1-33](#)
- distance limitations, transmission [2-3](#)
- DRAM
  - SIMM cautions and configurations [1-12](#)

---

## E

- EEPROM, MAC address bank [1-30](#)
- electromagnetic pulse (EMP), avoiding [2-3](#)
- electrostatic discharge, preventing [2-2](#)
- EMI, shielding [2-2](#)
- enable command [4-9](#)
- enable password [4-1](#)
- enable secret password [4-1](#)
- environmental monitor, description [1-31](#)
- Ethernet, interface configuration parameters [4-6](#)
- examples
  - configuring global parameters [4-4](#)
  - configuring I/O controller Fast Ethernet full-duplex [1-23](#)
  - configuring I/O controller Fast Ethernet media type [1-23](#)
- copying
  - images between Flash memory cards [5-11](#)
  - images to a Flash memory card [5-10](#)

Ethernet and serial interface configuration [4-8](#)  
 formatting a new Flash memory card [5-9](#)  
 replacing a port adapter [5-4](#)  
 replacing a service adapter [5-4](#)  
 setup command facility [4-6](#)  
 show diag command output [1-22, 5-1](#)  
 show environment all command output [1-35](#)  
 show environment command output [1-33](#)  
 show environment last command output [1-34](#)  
 show interfaces command output [1-29](#)  
 show version command output [1-13, 5-1](#)  
 EXEC mode [4-1](#)  
 exhaust air [1-33](#)

---

## F

fan failures [1-35](#)  
 field-replaceable units (FRUs) [1-7](#)  
 filler panels  
   port adapter [2-8](#)  
   power supply [2-8](#)  
 Flash memory  
   copy command [5-12](#)  
   copying between cards [5-11](#)  
   copying files [5-10](#)  
 Flash memory card  
   formatting a new Flash memory card [5-9](#)  
   inserting and removing a Flash memory card [5-7](#)  
   memory options [1-27](#)  
   physical description [1-27](#)  
 Flash memory disk  
   memory options [1-28](#)  
   physical description [1-27](#)  
 FRUs, listing [1-7](#)

---

## G

global parameters, configuring [4-3](#)

ground receptacles, chassis [1-4](#)

---

## H

handles  
   I/O controller [1-2](#)  
   network processing engine [1-4](#)  
   port adapter [1-3, 5-5](#)  
   power supply [1-24](#)  
 hardware address [1-28](#)

---

## I

I/O controller  
   handling [2-2](#)  
   LEDs [6-3](#)  
   MII receptacle [3-17](#)  
   normal startup [6-3](#)  
   physical description [1-14](#)  
   reset button [1-18](#)  
   RJ-45 port [3-18](#)  
   subsystem for troubleshooting [6-6](#)  
 identifying startup problems [6-3](#)  
 IGRP [4-5](#)  
 installation  
   checking shipping container [2-11](#)  
   checklist [2-10](#)  
   configuring Cisco 7206 [4-2](#)  
   connecting I/O controller cables [3-14](#)  
   connecting port adapter cables [3-14](#)  
   connecting power [3-20](#)  
   grounding the chassis [3-12](#)  
   initial configuration information [2-9](#)  
   installing brackets on the chassis [3-5](#)  
   installing chassis in a rack [3-2](#)  
   installing chassis on a tabletop (general installation) [3-9](#)  
   interface parameters [4-6](#)  
   preparing for [2-1](#)

starting the Cisco 7206 [3-24](#)  
 tools for [2-8](#)  
 interface  
   configuration [4-6](#)  
   parameters [4-6](#)  
 interference, radio frequency [2-2](#)  
 Interior Gateway Routing Protocol (IGRP) [4-5](#)  
 interior routing protocol (IGRP), setting [4-5](#)  
 Internet Package Exchange (IPX), configuring [4-5](#)  
 IP, setting routing protocols for [4-5](#)  
 IPX [4-5](#)

---

## L

LEDs  
   DC OK [3-24](#)  
   enabled on interface processors [3-24](#)  
   I/O controller [6-3](#)  
   PCMCIA slots 0 and 1 [1-22](#)  
   power supply [1-24, 6-3](#)  
 lifting the chassis [3-9](#)

---

## M

messages  
   environmental [1-33](#)  
   fan failure [2-8](#)  
 MII receptacle on I/O controller, pinouts [3-18](#)  
 modifications to configuration, reviewing [4-10](#)

---

## N

network processing engine  
   handling [2-2](#)  
   physical description [1-7](#)  
   subsystem for troubleshooting [6-7](#)  
   system management functions [1-9](#)  
 nonvolatile random-access memory

  See NVRAM [4-10](#)  
 normal status level, environmental monitor [1-32, 1-33](#)  
 note, description [ix](#)  
 numbering  
   logical interface [1-28](#)  
   port adapter slot [1-28](#)  
 NVRAM  
   log [1-32](#)  
   saving and viewing contents [4-10](#)  
   See nonvolatile random-access memory

---

## O

OIR, functional description [1-30](#)  
 operating conditions for chassis [1-25, 2-2](#)  
 out-of-tolerance temperature condition [1-32](#)  
 out-of-tolerance voltage condition [1-32](#)  
 overheating, preventing [2-8](#)  
 overtemperature conditions [6-3](#)

---

## P

password, enable and enable secret [4-1](#)  
 physical description  
   field-replaceable units  
     Flash memory cards [1-27](#)  
     Flash memory disks [1-27](#)  
     I/O controller [1-14](#)  
     network processing engine [1-7](#)  
     port and service adapters [1-24](#)  
     power supplies [1-24](#)  
 pinouts  
   MII receptacle on I/O controller [3-18](#)  
   RJ-45 receptacle on I/O controller [3-19](#)  
 port adapters  
   filler [2-8](#)  
   handling [2-2, 5-5](#)  
   logical interface numbering [1-28](#)

- physical description 1-24
  - slot numbering 1-3, 1-28
  - subsystem for troubleshooting 6-7
- power
- connections 3-20
  - cord 1-24, 6-5
  - DC status 1-32
  - site requirements 2-2
  - subsystem, for troubleshooting 6-3
  - surge suppression 2-3
- power factor corrector, power supply 2-2
- power supply
- and environmental monitor 1-32
  - description 1-4
  - disabled 1-32
  - filler 2-8
  - LEDs 1-24, 6-3
  - physical description 1-24
  - power factor corrector 2-2
  - shutdown 1-32
  - troubleshooting 6-3
- privileged command level 4-1
- procedures
- checking shipping container 2-11
  - configuring the Cisco 7206 4-2
  - connecting I/O controller cables 3-14
  - connecting port adapter cables 3-14
  - connecting power 3-20
  - copying images between Flash memory cards 5-11
  - copying images to a Flash memory card 5-10
  - formatting a new Flash memory card 5-9
  - grounding the chassis 3-12
  - installing and removing a Flash memory card 5-7
  - installing brackets on the chassis 3-5
  - installing chassis on a tabletop (general installation) 3-9
  - rack-mounting chassis 3-2
  - replacing a port adapter 5-4
  - replacing a service adapter 5-4
- replacing or recovering a lost password 5-14
  - starting the Cisco 7206 3-24
  - viewing your system configuration 5-1
- processor
- shutdown 1-32
  - system for troubleshooting 6-3
- 
- ## R
- rack-mount installation 3-1
- rack-mount kit
- hardware 2-11
  - installation 3-2
- radio frequency interference
- See RFI 2-3
- replacing a port adapter 5-4
- replacing a service adapter 5-4
- replacing or recovering a lost password 5-14
- reviewing changes to configuration 4-10
- RFI 2-3
- RIP 4-5
- RJ-45 receptacle, I/O controller
- crossover cable 3-19
  - straight-through cable 3-19
- RJ-45 receptacle on I/O controller, pinouts 3-19
- Routing Information Protocol
- See RIP 4-5
- 
- ## S
- saving the configuration file 4-9, 4-10
- service adapters
- physical description 1-24
  - subsystem for troubleshooting 6-7
- setup command 4-3
- setup command facility 2-9
- example 4-6
  - script

- banner information (example) 4-3
- interface summary (example) 4-4
- System Configuration Dialog (example) 4-4
- setup command facility configuration, basic 4-3
- show diag command 1-22, 5-1
- show environment command 1-33, 2-8
- show environment last command 1-34
- show environment table command 1-34
- show interfaces command 1-29
- show running-config command 4-10
- show startup-config command 4-10
- show version command 1-13, 5-1
- shutdown
  - environmental 1-31
  - fan failure 1-35
  - power supply 1-32
  - processor 1-32
  - thresholds 1-31
- Simple Network Management Protocol
  - See SNMP 4-5
- site log 2-12
- site requirements
  - environment 2-6
  - equipment racks 2-4
  - plant wiring 2-2
  - power 2-2
  - preventive configuration 2-6
- slot/port numbers for interfaces 1-28
- SNMP 4-5
- SNMP management 1-9
- software requirements 1-6
- startup, system 3-24
- status
  - DC power 1-32
  - environmental 1-33, 2-8
  - interfaces 1-29
- straight-through cable, RJ-45 receptacle on I/O controller 3-19
- subsystems for troubleshooting

- cooling 6-7
- I/O controller 6-6
- network processing engine 6-7
- port adapters 6-7
- power 6-5
- service adapters 6-7
- switch
  - power 1-25
- synchronous serial interfaces, configuring 4-7
- system specifications 1-5

---

## T

- telco-type equipment racks 2-4, 3-1, 3-9
- temperature, internal chassis 1-31
- terminology xiii
- thresholds, shutdown 1-31
- tools, for installation 2-8
- troubleshooting
  - cooling subsystem 6-7
  - power subsystem 6-5
  - processor subsystem 6-6
  - startup problems 6-3
  - strategy 6-2

---

## W

- warnings
  - warning definition x
- warning status level, environmental monitor 1-32
- wiring
  - color codes 1
  - interference 2-2
  - plant 2-2
  - telephone industry 25-pair color code 1