

CISCO VALIDATED PROFILE

Wireless Education Vertical

April 2016

Table of Contents

Profile Introduction	1
Security	1
Specialized Services	1
Migration to IPv6	1
Mobility.....	1
High Availability	1
Efficient Network Management	1
Performance and Scalability.....	2
Network Profile	3
Topology Diagram	3
Hardware Profile	4
Test Environment	5
Test Methodology	5
Use Cases	6
Appendix A	9

Profile Introduction

The Enterprise market segment can be divided into five broader verticals: Education, Healthcare, Retail, Service Provider, and Government. This document focuses on a typical Education deployment profile, and you can use it as a reference validation document for a University profile.

Education network environments combine the technology requirements of large enterprises with a specialized set of demands that includes security needs, enhanced network services, seamless mobility, network high availability, and efficient network management. The following sections describe the challenges specific to these environments.

SECURITY

Universities need to protect personal, academic, and copyrighted information with security-rich features such as rogue detection/containment, Intrusion Prevention (WIDS/WIPS), DOT1X, and guest-access (centralized and local web-auth).

SPECIALIZED SERVICES

Educational infrastructures must enable traditional and specialized resources in order to provide accessibility and speed. Network services such as video delivery, BYOD, AVC, NetFlow, mDNS, and Quality of Experience with custom QoS are deployed.

MIGRATION TO IPV6

Devices increasingly run on IPv6, while network infrastructures are likely to continue on IPv4. Dual Stack deployments with features such as IPv6 access and IPv6 Multicast are enabled for this Education vertical guide.

MOBILITY

Seamless mobility for a large number of clients is essential to supporting uninterrupted voice and data services. Fast roaming such as CCKM and 802.11 r/k/v is enabled for this vertical.

HIGH AVAILABILITY

Education infrastructures cannot afford downtime in their networks. The network should be able to sustain catastrophic events such as AP or Controller outage. Self-healing RF network and Client SSO are deployed.

EFFICIENT NETWORK MANAGEMENT

Network administrators should be able to efficiently manage and monitor their networks. The administrators could use Cisco-provided tools such as Cisco Prime Infrastructure and WebUI to quickly deploy, manage, monitor, and troubleshoot the end-to-end network.

PERFORMANCE AND SCALABILITY

Universities and colleges face tight IT budgets and steep technology demands. Various models of Wireless Controller (WLC 5520, WLC 8540) and 802.11AC Access Point (AP1832, AP1852, and AP3700) can meet the demand for both scalability and performance.

The following table summarizes key areas on which this Education profile focuses.

Table 1 Education Profile feature summary

Deployment areas	Features
Security	Rogue detection and containment Intrusion Prevention (WDS/wIPS) Dot1x Authentication Guest Access: Local WebAuth, Central WebAuth
Network services	Video Content Delivery (L2/L3 Multicast) BYOD mDNS Application, Visibility, and Control (AVC) Custom QoS
IPv6 migration	Dual Stack, IPv6 security
Mobility	Fast roaming OKC, CCKM 802.11 r/k/v Fast SSID
High availability	Client SSO N+1 Redundancy
Network planning & troubleshooting	NetFlow RF Sniffer
Efficient network management	Cisco Prime Infrastructure WebUI
Performance and scalability	High Performance/Capacity Wireless Controller and Wave 2 Access Points

Network Profile

Based on the research, customer feedback, and configuration samples, the Education Vertical Profile is designed with a deployment topology that is generic and can easily be modified to fit any specific deployment scenario.

TOPOLOGY DIAGRAM

Figure 1 shows the University Campus three-tiers design that is used for the validation of the Education Vertical Profile.

The topology represents a typical University Campus deployment with a Cisco Catalyst 4500/Catalyst 6500 in the distribution layer and a Catalyst 6500 in the core layer. Based on the size of the campus (both its geographical location and user-scale), there might be more distribution switches connecting to the core layer.

Figure 1 Education Vertical Profile: topology overview

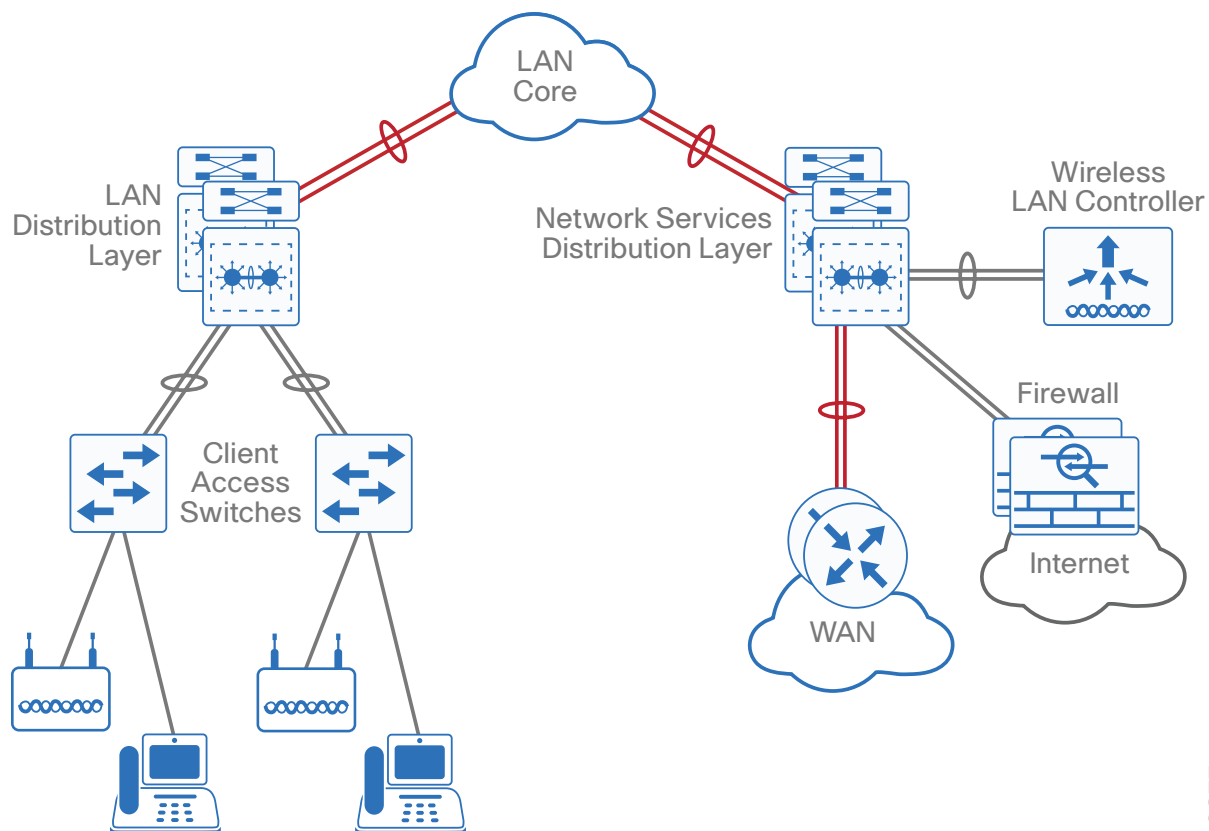

2087F

HARDWARE PROFILE

Table 2 defines the set of relevant hardware, servers, test equipment, and endpoints that are used to complete the end-to-end Education Vertical Profile deployment.

The list of hardware, along with the relevant software versions and the role of these devices, complement the actual physical topology defined in Figure 1.

Table 2 *Hardware profile of servers and endpoints*

VM and HW	Software versions	Description
Cisco Prime	Version 3.0	For Network Management
Cisco ISE	Version 1.3/1.4	Radius Server used for authentication, authorization
CUCM	Version 10.1	CUCM Server for managing IP phones
DNS/AD Server	Windows 8 Enterprise Server	Windows External server for DNS and Active Directory management
APIC-EM Plug-n-Play	Version 1.0.1	For Day0 Config and Image Management
Cisco UCS Server	ESXi 5.5	To manage and host the virtual machines
Ixia	IxNetwork/IxExplorer	Generate traffic streams and to emulate dot1x clients
Ixia Veriwave	Veriwave	Wireless endpoints with scale.
Cisco Unified IP Phones 796x, 796x, 9971	Cisco IP phones	Endpoints
Laptops	Windows 8, Windows 10	Endpoints
Macbook	Mac OSX	Endpoints for SDG
Apple TV		SDG server
Apple iPhone/iPad		Endpoints
IP camera		Endpoints
Printer		Endpoints

TEST ENVIRONMENT

This section describes the features and the relevant scales at which the features are deployed across the physical topology. Table 3 lists the scale for each feature.

Table 3 Education Profile: feature scale

Feature	Scale
Access points	800 APs (WLC-5520), 5000 APs (WLC-8540) (Real and simulated)
Clients	10K clients (WLC-5520), 50K Clients (WLC-8540) (Real and simulated)
WLANs	450
AP groups	500
Wireless interface	500
Trap receivers	6
IPv4 ACLs	64
IPv6 ACLs	64
Mobility Groups	10
IGMP snooping	300 groups
NetFlow	6 monitors+2k flows
SNMP	PI/MIB walks

Use Case Scenarios

TEST METHODOLOGY

The use cases listed in Table are executed using the topology defined in Figure 1, along with the Test environment shown in Table 3.

With respect to the longevity for this profile setup, CPU and memory use are monitored overnight and during the weekends, along with any memory-leak checks. In order to test the robustness, certain negative events would be triggered during the use-case testing.

USE CASES

Table 4 describes the use cases that were executed on the Educational Vertical Profile. These use cases are divided into buckets of technology areas to show the complete coverage of the deployment scenarios.

These technology buckets are composed of system upgrade, security, network services, monitoring & troubleshooting, simplified management, and system health monitoring along with system and network resiliency.

Table 4 List of use case scenarios

No.	Focus area	Use cases
System upgrade		
1	Upgrade	<p>Network administrator should be able to perform WLC upgrade and downgrade between releases seamlessly.</p> <ul style="list-style-type: none"> All of the configuration should be migrated seamlessly during the upgrade/downgrade operation. SW Install, Clean, Expand
Security		
2	On-Wire Attacks	<p>Network admin wants to detect and mitigate on-wire attacks.</p> <ul style="list-style-type: none"> Rogue on wired detection, containment
3	Over-the-Air Attacks	<p>Network admin wants to detect and mitigate wireless thread.</p> <ul style="list-style-type: none"> Adaptive wIPS Enhanced Local Mode (ELM) wIPS
4	Guest-Access	<p>Network admin wants to provide temporary guest access using the LWA and CWA.</p> <ul style="list-style-type: none"> LWA—Custom/Default Pages CWA—Self Register Guest Portal
Network services		
5	Multicast Video	<p>Network admin wants to enable and deploy multicast services.</p> <ul style="list-style-type: none"> V4 & V6 Multicast L3/L2 Multicast video delivery using PIM-SM, SSM, IGMP/MLD Snooping
6	SDG	<p>Network admin enables the SDG services on wired networks so that teachers can access IT-maintained Apple TVs and printers and students can access only the printers.</p>

Table 4 continued

7	Custom QoS	<p>Network admin needs to enhance user experience by ensuring traffic and application delivery using custom QoS policies.</p> <ul style="list-style-type: none"> ▪ Traffic types: VOIP, Video, Call Control, Transactional Data, Bulk Data, Scavenger ▪ Policing Ingress and Priority & BW Management in Egress
8	Plug-n-Play	<p>Simplify network provisioning of new switches by Zero-Touch-Deployment for Day0 using NG-PNP app via APIC-EM for image and configuration management.</p>
Monitoring & troubleshooting		
9	Client Troubleshooting	<p>Network admin should be able to troubleshoot client connectivity issues.</p> <ul style="list-style-type: none"> ▪ Service Assurance
10	NetFlow	<p>Enable IT admins to determine network resource usage and capacity planning by monitoring IP traffic flows using Flexible NetFlow.</p> <ul style="list-style-type: none"> ▪ Traffic types: L2, IPv4, IPv6 ▪ Lancope ▪ Prime Collector, Live Action
Simplified management		
11	Prime-Manage-Monitor	<p>Network admin wants to manage and monitor all the devices in the network using Cisco Prime Infrastructure.</p>
12	Prime-SWIM	<p>Network admin should be able to manage images on network devices using Cisco Prime Infrastructure for upgrade/downgrade.</p>
13	Prime-Template	<p>Network admin wants to configure deployment using Cisco Prime Infrastructure</p> <ul style="list-style-type: none"> ▪ Import and deploy customer-specific configuration templates ▪ Schedule configuration for immediate or later deployment ▪ Simplify configuration using config-templates
14	Prime-Troubleshooting	<p>Simplify network troubleshooting and debugging for IT admins</p> <ul style="list-style-type: none"> ▪ Monitor & troubleshoot end-end deployment via maps & topologies ▪ Monitor network for alarms, syslogs and traps ▪ Troubleshoot network performance using traffic flow monitoring

Table 4 continued

System health monitoring		
15	System Health	Monitor system health for CPU usage, memory consumption, and memory leaks during longevity
System & network resiliency, robustness		
16	System Resiliency	Verify system level resiliency during the following events: <ul style="list-style-type: none"> ▪ Active WLC failure ▪ Standby WLC failure ▪ RP link flaps ▪ Power failure ▪ Partial LAG failure ▪ AP Failure
17	Network Resiliency	High availability of the network during system failures using: <ul style="list-style-type: none"> ▪ VSS
18	Negative Events, Triggers	Verify that the system holds well and recovers to working condition after the following events are triggered: <ul style="list-style-type: none"> ▪ Config Changes—Add/Remove config snippets, Default-Interface configs ▪ Link Flaps, SVI Flaps ▪ Clear Counters, Clear ARP, Clear Routes, Clear access-sessions, Clear multicast routes ▪ IGMP/MLD Join, Leaves ▪ Burst client association ▪ Radius failure ▪ DHCP failure ▪ WLAN Flaps

Appendix A

You can find example configurations at the following location:

<http://cvddocs.com/fw/cvpconfig>





Please use the [feedback form](#) to send comments and suggestions about this guide.



Americas Headquarters
Cisco Systems, Inc.
San Jose, CA

Asia Pacific Headquarters
Cisco Systems (USA) Pte. Ltd.
Singapore

Europe Headquarters
Cisco Systems International BV Amsterdam,
The Netherlands

Cisco has more than 200 offices worldwide. Addresses, phone numbers, and fax numbers are listed on the Cisco Website at www.cisco.com/go/offices.

ALL DESIGNS, SPECIFICATIONS, STATEMENTS, INFORMATION, AND RECOMMENDATIONS (COLLECTIVELY, "DESIGNS") IN THIS MANUAL ARE PRESENTED "AS IS," WITH ALL FAULTS. CISCO AND ITS SUPPLIERS DISCLAIM ALL WARRANTIES, INCLUDING, WITHOUT LIMITATION, THE WARRANTY OF MERCHANTABILITY, FITNESS FOR A PARTICULAR PURPOSE AND NONINFRINGEMENT OR ARISING FROM A COURSE OF DEALING, USAGE, OR TRADE PRACTICE. IN NO EVENT SHALL CISCO OR ITS SUPPLIERS BE LIABLE FOR ANY INDIRECT, SPECIAL, CONSEQUENTIAL, OR INCIDENTAL DAMAGES, INCLUDING, WITHOUT LIMITATION, LOST PROFITS OR LOSS OR DAMAGE TO DATA ARISING OUT OF THE USE OR INABILITY TO USE THE DESIGNS, EVEN IF CISCO OR ITS SUPPLIERS HAVE BEEN ADVISED OF THE POSSIBILITY OF SUCH DAMAGES. THE DESIGNS ARE SUBJECT TO CHANGE WITHOUT NOTICE. USERS ARE SOLELY RESPONSIBLE FOR THEIR APPLICATION OF THE DESIGNS. THE DESIGNS DO NOT CONSTITUTE THE TECHNICAL OR OTHER PROFESSIONAL ADVICE OF CISCO, ITS SUPPLIERS OR PARTNERS. USERS SHOULD CONSULT THEIR OWN TECHNICAL ADVISORS BEFORE IMPLEMENTING THE DESIGNS. RESULTS MAY VARY DEPENDING ON FACTORS NOT TESTED BY CISCO.

Any Internet Protocol (IP) addresses used in this document are not intended to be actual addresses. Any examples, command display output, and figures included in the document are shown for illustrative purposes only. Any use of actual IP addresses in illustrative content is unintentional and coincidental.

© 2016 Cisco Systems, Inc. All rights reserved.

Cisco and the Cisco logo are trademarks or registered trademarks of Cisco and/or its affiliates in the U.S. and other countries. To view a list of Cisco trademarks, go to this URL: www.cisco.com/go/trademarks. Third-party trademarks mentioned are the property of their respective owners. The use of the word partner does not imply a partnership relationship between Cisco and any other company. (1110R)