



## **Cisco ASR 1000 Series Aggregation Services Routers SIP and SPA Hardware Installation Guide**

November 24, 2017

### **Cisco Systems, Inc.**

[www.cisco.com](http://www.cisco.com)

Cisco has more than 200 offices worldwide. Addresses, phone numbers, and fax numbers are listed on the Cisco website at [www.cisco.com/go/offices](http://www.cisco.com/go/offices).

THE SPECIFICATIONS AND INFORMATION REGARDING THE PRODUCTS IN THIS MANUAL ARE SUBJECT TO CHANGE WITHOUT NOTICE. ALL STATEMENTS, INFORMATION, AND RECOMMENDATIONS IN THIS MANUAL ARE BELIEVED TO BE ACCURATE BUT ARE PRESENTED WITHOUT WARRANTY OF ANY KIND, EXPRESS OR IMPLIED. USERS MUST TAKE FULL RESPONSIBILITY FOR THEIR APPLICATION OF ANY PRODUCTS.

THE SOFTWARE LICENSE AND LIMITED WARRANTY FOR THE ACCOMPANYING PRODUCT ARE SET FORTH IN THE INFORMATION PACKET THAT SHIPPED WITH THE PRODUCT AND ARE INCORPORATED HEREIN BY THIS REFERENCE. IF YOU ARE UNABLE TO LOCATE THE SOFTWARE LICENSE OR LIMITED WARRANTY, CONTACT YOUR CISCO REPRESENTATIVE FOR A COPY.

The following information is for FCC compliance of Class A devices: This equipment has been tested and found to comply with the limits for a Class A digital device, pursuant to part 15 of the FCC rules. These limits are designed to provide reasonable protection against harmful interference when the equipment is operated in a commercial environment. This equipment generates, uses, and can radiate radio-frequency energy and, if not installed and used in accordance with the instruction manual, may cause harmful interference to radio communications. Operation of this equipment in a residential area is likely to cause harmful interference, in which case users will be required to correct the interference at their own expense.

The following information is for FCC compliance of Class B devices: This equipment has been tested and found to comply with the limits for a Class B digital device, pursuant to part 15 of the FCC rules. These limits are designed to provide reasonable protection against harmful interference in a residential installation. This equipment generates, uses and can radiate radio frequency energy and, if not installed and used in accordance with the instructions, may cause harmful interference to radio communications. However, there is no guarantee that interference will not occur in a particular installation. If the equipment causes interference to radio or television reception, which can be determined by turning the equipment off and on, users are encouraged to try to correct the interference by using one or more of the following measures:

- Reorient or relocate the receiving antenna.
- Increase the separation between the equipment and receiver.
- Connect the equipment into an outlet on a circuit different from that to which the receiver is connected.
- Consult the dealer or an experienced radio/TV technician for help.

Modifications to this product not authorized by Cisco could void the FCC approval and negate your authority to operate the product.

The Cisco implementation of TCP header compression is an adaptation of a program developed by the University of California, Berkeley (UCB) as part of UCB's public domain version of the UNIX operating system. All rights reserved. Copyright © 1981, Regents of the University of California.

NOTWITHSTANDING ANY OTHER WARRANTY HEREIN, ALL DOCUMENT FILES AND SOFTWARE OF THESE SUPPLIERS ARE PROVIDED "AS IS" WITH ALL FAULTS. CISCO AND THE ABOVE-NAMED SUPPLIERS DISCLAIM ALL WARRANTIES, EXPRESSED OR IMPLIED, INCLUDING, WITHOUT LIMITATION, THOSE OF MERCHANTABILITY, FITNESS FOR A PARTICULAR PURPOSE AND NONINFRINGEMENT OR ARISING FROM A COURSE OF DEALING, USAGE, OR TRADE PRACTICE.

IN NO EVENT SHALL CISCO OR ITS SUPPLIERS BE LIABLE FOR ANY INDIRECT, SPECIAL, CONSEQUENTIAL, OR INCIDENTAL DAMAGES, INCLUDING, WITHOUT LIMITATION, LOST PROFITS OR LOSS OR DAMAGE TO DATA ARISING OUT OF THE USE OR INABILITY TO USE THIS MANUAL, EVEN IF CISCO OR ITS SUPPLIERS HAVE BEEN ADVISED OF THE POSSIBILITY OF SUCH DAMAGES.

Cisco and the Cisco logo are trademarks or registered trademarks of Cisco and/or its affiliates in the U.S. and other countries. To view a list of Cisco trademarks, go to this URL: [www.cisco.com/go/trademarks](http://www.cisco.com/go/trademarks). Third-party trademarks mentioned are the property of their respective owners. The use of the word partner does not imply a partnership relationship between Cisco and any other company. (1721R)

Any Internet Protocol (IP) addresses and phone numbers used in this document are not intended to be actual addresses and phone numbers. Any examples, command display output, network topology diagrams, and other figures included in the document are shown for illustrative purposes only. Any use of actual IP addresses or phone numbers in illustrative content is unintentional and coincidental.

*Cisco ASR 1000 Series Aggregation Services Routers SIP and SPA Hardware Installation Guide*  
© 2008-2016 Cisco Systems, Inc. All rights reserved.



**Preface** xi

- Objectives xi
- Document Revision History xi
- Organization xv
- Related Documentation xv
- Obtaining Documentation and Submitting a Service Request xvi

---

**CHAPTER 1**

**SIP and SPA Product Overview** 1-1

- Introduction to SIPs and SPAs 1-1
  - SPA Interface Processors 1-1
  - Shared Port Adapters 1-2
- SIP and SPA Compatibility 1-3
- Modular Optics Compatibility 1-6

---

**CHAPTER 2**

**Overview: Cisco ASR 1000 Series Aggregation Services Routers SIPs** 2-1

- SIP Summary 2-1
  - Checking Hardware and Software Compatibility 2-2
- SPA Interface Addresses on SIPs 2-3
- Identifying Slots and Subslots for SIPs and SPAs 2-3
  - Specifying the Slot Location for a SIP 2-3
  - Specifying the SIP Subslot Location for a SPA 2-5
- Cisco ASR 1000 Series SPA Interface Processor Overview 2-7
  - Cisco ASR1000-SIP10 Overview 2-7
    - Cisco ASR1000-SIP10 LEDs 2-8
    - Cisco ASR1000-SIP10 Physical Specifications 2-8
  - Cisco ASR1000-SIP40 Overview 2-9
    - Cisco ASR1000-SIP40 LEDs 2-10
    - Cisco ASR1000-SIP40 Physical Specifications 2-11
  - Cisco ASR 1013 Router and Slot Numbering for SIP 2-11

---

**CHAPTER 3**

**Overview: Cisco ASR 1000 Series Aggregation Services Routers SPAs** 3-1

- SPA Summary 3-2
  - Checking Hardware and Software Compatibility 3-5

Bandwidth Oversubscription	<b>3-5</b>
Cisco ASR1000-SIP10 Oversubscription Guidelines	<b>3-7</b>
Cisco ASR1000-SIP40 Oversubscription Guidelines	<b>3-7</b>
1-Port and 3-Port Clear Channel OC-3 ATM SPA Overview	<b>3-8</b>
1-Port and 3-Port Clear Channel OC-3 ATM SPA LEDs	<b>3-8</b>
1-Port and 3-Port Clear Channel OC-3 ATM SPA Interface Specifications	<b>3-9</b>
1-Port and 3-Port Clear-Channel OC-3 ATM SPA Cables and Connectors	<b>3-9</b>
1-Port Clear Channel OC-12 ATM SPA Overview	<b>3-10</b>
1-Port Clear Channel OC-12 ATM SPA LEDs	<b>3-11</b>
1-Port Clear Channel OC-12 ATM SPA Interface Specifications	<b>3-12</b>
1-Port Clear Channel OC-12 ATM SPA Cables and Connectors	<b>3-12</b>
4-Port and 8-Port Fast Ethernet SPA Overview	<b>3-13</b>
4-Port and 8-Port Fast Ethernet SPA LEDs	<b>3-13</b>
4-Port and 8-Port Fast Ethernet SPA Cables, Connectors, and Pinouts	<b>3-14</b>
1-Port 10-Gigabit Ethernet SPA Overview	<b>3-15</b>
1-Port 10-Gigabit Ethernet SPA LEDs	<b>3-16</b>
1-Port 10-Gigabit Ethernet SPA XFP Optical Transceiver Modules, Connectors, and Cables	<b>3-17</b>
XFP Connections	<b>3-17</b>
XFP Port Cabling Specifications	<b>3-19</b>
2-Port Gigabit Ethernet SPA Overview	<b>3-19</b>
2-Port Copper and Optical Gigabit Ethernet SPA LEDs	<b>3-19</b>
2-Port Copper and Optical Gigabit Ethernet SPA Cables, Connectors, and Pinouts	<b>3-20</b>
SFP Module Connections	<b>3-20</b>
Cables, Connectors, and Pinouts	<b>3-20</b>
5-Port Gigabit Ethernet SPA Overview	<b>3-21</b>
5-Port Gigabit Ethernet SPA LEDs	<b>3-21</b>
5-Port Gigabit Ethernet SPA Connectors	<b>3-23</b>
SFP Module Connections	<b>3-23</b>
8-Port Gigabit Ethernet SPA Overview	<b>3-23</b>
8-Port Gigabit Ethernet SPA LEDs	<b>3-24</b>
8-Port Gigabit Ethernet SPA Connectors	<b>3-24</b>
SFP Module Connections	<b>3-24</b>
10-Port Gigabit Ethernet SPA Overview	<b>3-25</b>
10-Port Gigabit Ethernet SPA LEDs	<b>3-25</b>
10-Port Gigabit Ethernet SPA Connectors	<b>3-26</b>
SFP Module Connections	<b>3-26</b>
SFP Module and Cabling Specifications for Gigabit Ethernet SPAs	<b>3-26</b>
SFP Module Specifications	<b>3-26</b>
SFP Module Cabling and Connection Equipment	<b>3-29</b>

CWDM and DWDM SFP Modules for Gigabit Ethernet SPAs	3-31
CWDM SFP Module Specifications for All Gigabit Ethernet SPAs Using SFP Modules	3-31
DWDM SFP Module Specifications	3-32
2-Port Gigabit Synchronous Ethernet SPA Overview	3-33
2-Port Gigabit Synchronous Ethernet SPA LEDs	3-33
2-Port Gigabit Synchronous Ethernet SPA Interface Specifications	3-34
Power Supply	3-35
Standards Compliance	3-35
2-Port Gigabit Synchronous Ethernet SPA Cables and Connectors	3-35
SFP Optics Module	3-35
BITS Interface	3-36
2-Port, 4-Port, and 8-Port OC-3c/STM-1 POS SPA Overview	3-36
2-Port and 4-Port OC-3c/STM-1 POS SPA LEDs	3-36
2-Port and 4-Port OC-3c/STM-1 POS SPA Interface Specifications	3-37
2-Port and 4-Port OC-3c/STM-1 POS SPA Optical Transceiver Modules and Cables	3-37
3-38	
1-Port and 2-Port OC-12c/STM-1 POS SPA	3-39
OC-3 Module Connections	3-40
1-Port OC-48c/STM-16 POS SPA Overview	3-41
1-Port OC-48c/STM-16 POS SPA LEDs	3-41
1-Port OC-48c/STM-16 POS SPA Interface Specifications	3-42
1-Port OC-48c/STM-16 POS SPA Optical Transceiver Modules, Connectors, and Cables	3-43
2-Port and 4-Port OC-48c/STM-16 POS SPA Overview	3-43
2-Port and 4-Port OC-48c/STM-16 POS SPA LEDs	3-44
2-Port and 4-Port OC-48c/STM-16 POS SPA Interface Specifications	3-45
2-Port and 4-Port OC-48c/STM-16 POS SPA Cables, Optical Transceiver Modules, and Connectors	3-45
OC-48 Module Connections	3-46
1-Port OC-12c/STM-4 POS SPA Overview	3-46
1-Port OC-12c/STM-4 POS SPA LEDs	3-46
1-Port OC-12c/STM-4 POS SPA Interface Specifications	3-47
1-Port OC-12c/STM-4 POS SPA SFP Optical Transceiver Modules and Cables	3-48
2-Port and 4-Port OC-12c/STM-1 POS SPA	3-49
2 port OC12 SPA (SPA-2XOC12-POS)	3-49
OC-12 Module Connections	3-50
2-Port, 4-Port, and 8-Port OC-12c/STM-4 POS SPA Overview	3-51
2-Port, 4-Port, and 8-Port OC-12c/STM-4 Multirate POS SPA LEDs	3-51
2-Port, 4-Port, and 8-Port OC-12c/STM-4 Multirate POS SPA Interface Specifications	3-52

2-Port, 4-Port, and 8-Port OC-12c/STM-4 Multirate POS SPA Optical Transceiver Modules, Connectors, and Cables	<b>3-52</b>
OC-12 Module Connections	<b>3-54</b>
1-Port OC-192c/STM-64 POS/RPR XFP SPA Overview	<b>3-54</b>
1-Port OC-192c/STM-64 POS/RPR XFP SPA LEDs	<b>3-55</b>
1-Port OC-192c/STM-64 POS/RPR XFP SPA Interface Specifications	<b>3-56</b>
1-Port OC-192c/STM-64 POS/RPR XFP SPA Optical Transceiver Modules, Connectors, and Cables	<b>3-56</b>
OC-192 Module Connections	<b>3-57</b>
2-Port, 4-Port, and 8-Port Clear-Channel T3/E3 Serial SPA Overview	<b>3-58</b>
2-Port, 4-Port, and 8-Port Clear-Channel T3/E3 SPA LEDs	<b>3-58</b>
2-Port, 4-Port, and 8-Port Clear-Channel T3/E3 SPA Interface Specifications	<b>3-59</b>
2-Port, 4-Port, and 8-Port Clear-Channel T3/E3 SPA Cables and Connectors	<b>3-59</b>
2-Port and 4-Port Channelized T3 Serial SPA Overview	<b>3-60</b>
2-Port and 4-Port Channelized T3 SPA LEDs	<b>3-61</b>
2-Port and 4-Port Channelized T3 SPA Interface Specifications	<b>3-62</b>
2-Port and 4-Port Channelized T3 SPA Cables and Connectors	<b>3-62</b>
4-Port Serial Interface SPA Overview	<b>3-63</b>
4-Port Serial Interface SPA LEDs	<b>3-63</b>
4-Port Serial Interface SPA Interface Specifications	<b>3-64</b>
4-Port Serial Interface SPA Cables, Connectors, and Pinouts	<b>3-65</b>
8-Port Channelized T1/E1 SPA Overview	<b>3-67</b>
8-Port Channelized T1/E1 Serial SPA LEDs	<b>3-67</b>
8-Port Channelized T1/E1 Serial SPA Interface Specifications	<b>3-68</b>
8-Port Channelized T1/E1 Serial SPA Cables, Connectors, and Pinouts	<b>3-68</b>
1-Port Channelized STM-1/OC-3 SPA Overview	<b>3-69</b>
1-Port Channelized STM-1/OC-3 SPA LEDs	<b>3-70</b>
1-Port Channelized STM-1/OC-3 SPA Interface Specifications	<b>3-70</b>
1-Port Channelized STM-1/OC-3 SPA Cables and Connectors	<b>3-71</b>
1-Port Channelized OC-12/STM-4 SPA Overview	<b>3-72</b>
1-Port Channelized OC-12/STM-4 SPA LEDs	<b>3-72</b>
1-Port Channelized OC-12/STM-4 SPA Interface Specifications	<b>3-73</b>
1-Port Channelized OC-12/STM-4 SPA Cables and Connectors	<b>3-73</b>
Cisco WebEx Node for ASR 1000 Series Overview	<b>3-75</b>
Cisco WebEx Node SPA LEDs	<b>3-75</b>
Cisco DSP SPA for ASR 1000 Series Overview	<b>3-76</b>
Understanding the Need for SPA-DSP	<b>3-76</b>
SPA-DSP Overview	<b>3-76</b>
Features of SPA-DSP	<b>3-78</b>

SPA-DSP LED	3-78
1-Port Channelized OC3 STM-1 ATM CEoP SPA Overview	3-79
1-Port Channelized OC-3 ATM CEoP SPA LEDs	3-79
1-Port Channelized OC-3 ATM CEoP SPA Interface Specifications	3-80
1-Port Channelized OC-3 ATM CEoP SPA Optical Transceiver Modules and Cables	3-80
2-Port Channelized T3/E3 ATM CEoP SPA Overview	3-81
2-Port Channelized T3/E3 ATM CEoP SPA LEDs	3-81
2-Port Channelized T3/E3 ATM CEoP SPA Interface Specifications	3-82
2-Port Channelized T3/E3 ATM CEoP SPA Cables and Connectors	3-82
24-Port Channelized T1/E1/J1 ATM CEoP SPA Overview	3-83
24-Port Channelized T1/E1/J1 CEoP SPA LEDs	3-83
24-Port Channelized T1/E1/J1 CEoP SPA Interface Specifications	3-84
24-Port Channelized T1/E1/J1 CEoP SPA Cables and Connectors	3-84
Cable Installation	3-85
SPA Cable Pinouts	3-85
RJ-45 Cable Pinouts	3-88
Patch Panel Cabling	3-88
24-Port Channelized T1/E1/J1 CEoP SPA Patch Panel	3-88

**CHAPTER 4****Preparing to Install a SIP or a SPA 4-1**

Required Tools and Equipment	4-1
Safety Guidelines	4-1
Safety Warnings	4-1
Warning Definition	4-2
Electrical Equipment Guidelines	4-8
Telephone Wiring Guidelines	4-8
Preventing Electrostatic Discharge Damage	4-8
Laser/LED Safety	4-9

**CHAPTER 5****Installing and Removing a SIP 5-1**

Handling SIPs	5-1
Online Insertion and Removal	5-2
Preparing for Online Removal of a SIP	5-2
Deactivating a SIP	5-3
Reactivating a SIP	5-3
Verifying the Deactivation and Activation of a SIP	5-4
Preparing for Online Removal of a SPA	5-5
Deactivating a SPA	5-6
Reactivating a SPA	5-7

- Verifying the Deactivation and Activation of a SPA 5-8
- Deactivation and Activation Configuration Examples 5-8
  - Deactivation of a SIP Configuration Example 5-8
  - Activation of a SIP Configuration Example 5-9
  - Deactivation of a SPA Configuration Example 5-9
  - Activation of a SPA Configuration Example 5-9
- SIP Installation and Removal 5-9

**CHAPTER 6**

**Installing and Removing a SPA 6-1**

- Handling SPAs 6-1
- SPA Installation and Removal 6-2
  - Installing a SPA in a SIP 6-2
  - Removing a SPA from a SIP 6-2
- Online Insertion and Removal 6-6
- Optical Device Maintenance 6-6
  - Cleaning Optical Devices 6-7
- Checking the Installation 6-7
  - Verifying the Installation 6-7
  - Using show Commands to Verify the SIP and SPA Status 6-8
  - Using show Commands to Display SPA Information 6-9
- SPA Blank Filler Plates 6-9
- SPA Cable Management Brackets 6-10

**CHAPTER 7**

**Troubleshooting the Installation 7-1**

- Troubleshooting the Hardware 7-1
  - SIP is Deactivated 7-2
  - SIP Transitions Repeatedly from On to Off 7-3
  - Troubleshooting the Cisco WebEx Node and SPA-DSP for ASR 1000 Series Hardware 7-3
    - Cisco WebEx Node SPA and SPA-DSP is in Out-of-Service State 7-3
    - Cisco WebEx Node SPA Has Issued Hardware Error Messages 7-7
    - Hard Disk Drive Errors on the Cisco WebEx Node SPA 7-8
    - Collecting the show tech-support Output from the Cisco WebEx Node SPA Console 7-10
  - Reformatting the Hard Disk Drive on the Cisco WebEx Node SPA 7-11
    - Prerequisites 7-11
  - Troubleshooting the 1-Port 10-Gigabit Ethernet LAN/WAN-PHY SPA for ASR 1000 Series Hardware 7-14
- Feature Change to CPU-Usage show Command 7-15
- Using debug Commands 7-17



Packing a SPA for Shipment **7-17**  
Packing a SIP for Shipment **7-20**





## Preface

---

This preface describes the objectives and organization of this document and explains how to find additional information on related products and services. This preface contains the following sections:

- [Objectives, page xi](#)
- [Document Revision History, page xi](#)
- [Organization, page xv](#)
- [Related Documentation, page xv](#)
- [Obtaining Documentation and Submitting a Service Request, page xvi](#)

## Objectives

This document describes the SPA interface processors (SIPs) and shared port adapters (SPAs) that are supported on the Cisco ASR 1000 Series Aggregation Services Routers. This document also describes how to install the supported SIPs and SPAs and how to troubleshoot the installation.

## Document Revision History

The Document Revision History records technical changes to this document. The table shows the Cisco IOS XE software release number and document revision number for the change, the date of the change, and a brief summary of the change.

Release No.	Revision	Date	Change Summary
Cisco IOS XE Denali 16.2	OL-14126-16	October 09, 2016	Added information pertaining to support for Cisco 10GBASE SFP+ Modules on Cisco ASR 1000 Series Aggregation Services Routers.
Cisco IOS XE Release 3.15	OL-14126-15	March 26, 2015	Added information pertaining to the support for the Cisco 1000BASE-T SFP Module (GLC-TE) on the ASR 1000 Series Routers.

Release No.	Revision	Date	Change Summary
Cisco IOS XE Release 3.8.1S	OL-14126-14	February 13, 2013	Added information pertaining to the support for the 8-Port Clear-Channel T3/E3 Serial SPA (SPA-8XT3/E3) on the Cisco ASR 1000 Series SIP in <a href="#">“2-Port, 4-Port, and 8-Port Clear-Channel T3/E3 Serial SPA Overview”</a> section on page 58.
Cisco IOS XE Release 3.7.0S	OL-14126-13	July 2012	<p>Added information pertaining to the following updates:</p> <ul style="list-style-type: none"> <li>• Introduction of the Cisco ASR 1002-X Router</li> <li>• Introduction of the Cisco ASR1000-ESP100</li> <li>• Support for Cisco ASR1000-SIP40 on all routers that support Cisco ASR1000-SIP10</li> </ul> <p>Information about these new features has been added in various sections in this guide.</p>
Cisco IOS XE Release 3.6.0S	OL-14126-12	March 29, 2012	Added information about support for the circuit emulation (CEM) mode on the <a href="#">2-Port Channelized T3/E3 ATM CEoP SPA</a> .
Cisco IOS XE Release 3.5.0S	OL-14126-11	November 28, 2011	Added information about feature enhancement in the following SPA: <a href="#">Support for ATM on clear E3 mode for SPA-2CHT3-CE-ATM</a>
Cisco IOS XE Release 3.4.0S	OL-14126-10	July 25, 2011	<p>Added information about the following SPAs:</p> <ul style="list-style-type: none"> <li>• <a href="#">SPA-2CHT3-CE-ATM (Asynchronous Transfer Mode only)</a></li> <li>• <a href="#">SPA-24CHT1-CE-ATM (Circuit Emulation mode only)</a></li> </ul> <p>Added information pertaining to feature change for <a href="#">CPU-Usage show command</a>.</p>
Cisco IOS XE Release 3.3.0S	OL-14126-09	March 30, 2011	<p>Added information about the following SPAs:</p> <ul style="list-style-type: none"> <li>• <a href="#">1-Port 10-Gigabit Ethernet LAN/WAN-PHY SPA</a></li> <li>• <a href="#">1-Port Channelized OC-3 STM1 ATM Circuit Emulation over Packet (CEoP) SPA (Circuit Emulation Mode only)</a></li> </ul>

Release No.	Revision	Date	Change Summary
Cisco IOS XE Release 3.2S	OL-14126-08	November 24, 2010	<p>Added information about the following SPAs:</p> <ul style="list-style-type: none"> <li>• <a href="#">2-Port Gigabit Synchronous Ethernet SPA</a></li> <li>• <a href="#">SPA-DSP</a></li> </ul> <p>Information added for supporting SIP-40 and ESP-40 on Cisco ASR 1004 Router.</p>
Cisco IOS XE Release 3.1S	OL-14126-07	July 23, 2010	<p>Added information about:</p> <ul style="list-style-type: none"> <li>• <a href="#">Cisco ASR1000-SIP40 in Cisco IOS XE Release 3.1S (the new hardware SIP)</a></li> <li>• <a href="#">default maximum bandwidth of SIP-10 when SIP-40 is downgraded to SIP-10</a></li> </ul>
Cisco IOS XE Release 2.6	OL-14126-06	February 26, 2010	<p>Information added for the following SPA and other information updates:</p> <ul style="list-style-type: none"> <li>• <a href="#">1-Port Channelized OC-12/STM-4 SPA</a></li> <li>• Updates for optics module behavior and compatibility including: <ul style="list-style-type: none"> <li>– Correction to show support for the GLC-GE-100FX optics module for the 5-Port and 10-Port Gigabit Ethernet SPA.</li> <li>– Correction to the auto negotiation behavior for the SFP-GE-T module.</li> <li>– Correction to show support for additional modules for the 2-Port, 4-Port, and 8-Port OC-3c/STM-1 and OC-12c/STM-4 POS SPA.</li> </ul> </li> <li>• Added descriptions for the services SPAs and double-height SPAs.</li> </ul>

Release No.	Revision	Date	Change Summary
Cisco IOS XE Release 2.5	OL-14126-05	November 25, 2009	<p>Information added for the following hardware in Cisco IOS XE Release 2.5:</p> <ul style="list-style-type: none"> <li>• <a href="#">1-Port Clear Channel OC-12 ATM SPA</a></li> <li>• Cisco 10GBASE-SR XFP transceiver module for MMF, 850-nm wavelength, dual LC connector (XFP-10G-MM-SR)</li> <li>• Cisco 1000BASE-BX10 SFP module for single-strand SMF, 1490-nm TX/1310-nm RX wavelength (GLC-BX-D)</li> <li>• Cisco 1000BASE-BX10 SFP module for single-strand SMF, 1310-nm TX/1490-nm RX wavelength (GLC-BX-U)</li> </ul>
Cisco IOS XE Release 2.4	OL-14126-04	June 30, 2009	<ul style="list-style-type: none"> <li>• Information added for the following SPAs: <ul style="list-style-type: none"> <li>– <a href="#">2-Port, 4-Port, and 8-Port OC-12 POS SPA</a></li> <li>– <a href="#">1-Port OC-48 POS SPA</a></li> <li>– <a href="#">8-Port OC-3 POS SPA</a></li> <li>– <a href="#">1-Port OC-192 POS SPA</a></li> <li>– <a href="#">Cisco WebEx Node for ASR 1000 Series SPA</a></li> </ul> </li> <li>• New information on the use of SPA cable clips to help with removal of SPAs from a SIP on the Cisco ASR 1000 Series Routers was added.</li> </ul>
Cisco IOS XE Release 2.3	OL-14126-03	November 24, 2008	<p>Information added for the following SPAs:</p> <ul style="list-style-type: none"> <li>• <a href="#">1-Port and 3-Port OC-3 ATM SPA</a></li> </ul>
Cisco IOS XE Release 2.2	OL-14126-02	September 10, 2008	<p>Information added for the following SPAs:</p> <ul style="list-style-type: none"> <li>• <a href="#">2-Port and 4-Port OC-48c/STM-16 POS SPA</a></li> <li>• <a href="#">1-Port Channelized STM-1/OC-3 SPA</a></li> </ul>
Cisco IOS XE Release 2.1	OL-14126-01	April 25, 2008	First release.

# Organization

This document contains the following chapters:

Section	Title	Description
Chapter 1	<a href="#">SIP and SPA Product Overview</a>	Provides an introduction to SPA interface processors (SIPs) and shared port adapters (SPAs).
Chapter 2	<a href="#">Overview: Cisco ASR 1000 Series Aggregation Services Routers SIPs</a>	Provides SIP and SPA compatibility summary. For each supported SIP, provides a summary of SIP characteristics and a SIP overview.
Chapter 3	<a href="#">Overview: Cisco ASR 1000 Series Aggregation Services Routers SPAs</a>	For each supported SPA, provides a summary of SPA characteristics and a SPA overview.
Chapter 4	<a href="#">Preparing to Install a SIP or a SPA</a>	Describes the required tools, equipment, and safety guidelines for installing SIPs and SPAs.
Chapter 5	<a href="#">Installing and Removing a SIP</a>	Describes the procedures involved in installing and removing a SIP on Cisco ASR 1000 Series Routers.
Chapter 6	<a href="#">Installing and Removing a SPA</a>	Describes the procedures for installing and removing a SPA on Cisco ASR 1000 Series Routers. It also describes how to verify the SIP and SPA installation.
Chapter 7	<a href="#">Troubleshooting the Installation</a>	Provides information about troubleshooting the installation of SIPs and SPAs. It also provides packing information to ship a SIP or SPA.

## Related Documentation

The documentation listed below is available online and on the Documentation DVD.

Your router and the Cisco IOS XE software running on it contain extensive features, which are documented in the following resources:

- [Cisco ASR 1000 Series Aggregation Services Routers SIP and SPA Software Configuration Guide](#)
- Cisco IOS XE software:
  - For Cisco IOS XE configuration information and support, refer to the Cisco IOS XE configuration guide or command reference. You can also refer to the specific Cisco IOS XE software document for a particular feature.
  - To see if a feature is supported by a Cisco IOS XE release, to locate the software document for that feature, or to check the minimum software requirements of Cisco IOS XE software with the hardware installed on your router, Cisco maintains the Software Advisor tool on Cisco.com. You must be a registered user on Cisco.com to access this tool. To access Software Advisor, click **Login** at Cisco.com, type “Software Advisor” in the SEARCH box, and click **GO**. Click the link for the Software Advisor tool.

**Note**

---

You can access Cisco IOS XE software configuration and hardware installation and maintenance documentation on the World Wide Web at <http://www.cisco.com>. Translated documentation is available at: <http://www.cisco.com/web/siteassets/locator/index.html>.

---

- For international agency compliance, safety, and statutory information for SPA interfaces, see the *Regulatory Compliance and Safety Information for the Cisco ASR 1000 Series Aggregation Services Routers*.

## Obtaining Documentation and Submitting a Service Request

For information on obtaining documentation, submitting a service request, and gathering additional information, see the monthly *What's New in Cisco Product Documentation*, which also lists all new and revised Cisco technical documentation, at:

<http://www.cisco.com/en/US/docs/general/whatsnew/whatsnew.html>

Subscribe to the *What's New in Cisco Product Documentation* as a Really Simple Syndication (RSS) feed and set content to be delivered directly to your desktop using a reader application. The RSS feeds are a free service and Cisco currently supports RSS version 2.0.





# SIP and SPA Product Overview

---

This chapter provides an introduction to SPA interface processors (SIPs) and shared port adapters (SPAs). It includes the following sections:

- [Introduction to SIPs and SPAs, page 1-1](#)
- [SIP and SPA Compatibility, page 1-3](#)
- [Modular Optics Compatibility, page 1-6](#)

For software details for the specific SIPs and SPAs that are supported on the Cisco ASR 1000 Series Aggregation Services Routers, refer to the companion publication, [Cisco ASR 1000 Series Aggregation Services Routers SIP and SPA Software Configuration Guide](#).

## Introduction to SIPs and SPAs

Cisco ASR 1000 Series Aggregation Services Routers SIPs and SPAs are a carrier card and port adapter architecture that increases modularity, flexibility, and density across Cisco routers for network connectivity. This section describes the SIPs and SPAs and provides some guidelines for their use.

## SPA Interface Processors

The following list describes some of the general characteristics of a SIP:

- A SIP is a carrier card that inserts into a router slot like a line card. It provides no network connectivity on its own.
- A SIP contains one or more subslots, which are used to house one or more SPAs. The SPA provides interface ports for network connectivity.
- During normal operation, the SIP should reside in the router fully populated either with functional SPAs in all subslots, or with a blank filler plate (SPA-BLANK=) inserted in all empty subslots.
- SIPs support online insertion and removal (OIR) with SPAs inserted in their subslots. SPAs also support OIR and can be inserted or removed independently from the SIP.



### Note

Fully populate all slots and subslots with blank filler plates or functional SPAs for maximum efficiency of the cooling system.

---

## Shared Port Adapters

The following list describes some of the general characteristics of a SPA:

- A SPA is a modular type of port adapter that inserts into a subslot of a compatible SIP carrier card to provide network connectivity and increased interface port density. A SIP can hold one or more SPAs, depending on the SIP type.
- Some SPAs provide services rather than network connectivity, and can be inserted into the subslots of a compatible SIP, for example, the Cisco WebEx Node for ASR 1000 Series that provides WebEx meeting services, and the DSP SPA that provides voice transcoding and transrating capabilities.
- SPAs are available in the following sizes, as shown in [Figure 1-1](#) and [Figure 1-2](#):
  - Single-height SPA—Inserts into one SIP subslot.
  - Double-height SPA—Inserts into two single, vertically aligned SIP subslots.

**Figure 1-1** Single-Height and Double-Height SPA Sizes

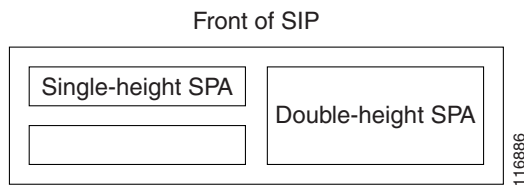

**Figure 1-2** Horizontal and Vertical Chassis Slot Orientation for SPAs

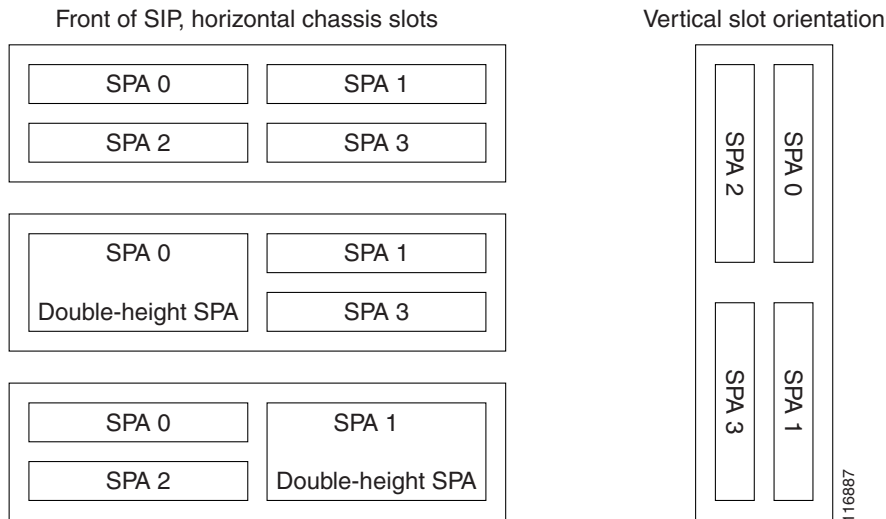

- Each SPA provides a certain number of connectors, or ports, that are the interfaces to one or more networks. These interfaces can be individually configured using the Cisco IOS command-line interface (CLI).
- Either a blank filler plate or a functional SPA should reside in every subslot of a SIP during normal operation to maintain cooling integrity. Blank filler plates are available in single-height form only.
- SPAs support online insertion and removal (OIR). They can be inserted or removed independently from the SIP. SIPs also support OIR with SPAs inserted in their subslots.

# SIP and SPA Compatibility

Table 1-1, Table 1-2, Table 1-3, Table 1-4, Table 1-5, and Table 1-6 show SIP and SPA compatibility by SPA technology area on the Cisco ASR 1000 Series Router.

**Note**

For more information about the support for different SIPs and SPAs, refer to the “Release History” section in the “Overview of the SIP” chapter of the *Cisco ASR 1000 Series Aggregation Services Routers SIP and SPA Software Configuration Guide*.

**Table 1-1 SIP and SPA Compatibility for ATM SPAs**

SPA	Product ID	SIP Supported: Cisco ASR1000-SIP10	SIP Supported: Cisco ASR1000-SIP40
1-Port Clear Channel OC-3 ATM SPA	SPA-1XOC3-ATM-V2	Yes	Yes
3-Port Clear Channel OC-3 ATM SPA	SPA-3XOC3-ATM-V2	Yes	Yes
1-Port Clear Channel OC-12 ATM SPA	SPA-1XOC12-ATM-V2	Yes	Yes

**Table 1-2 SIP and SPA Compatibility for Ethernet SPAs**

SPA	Product ID	SIP Supported: Cisco ASR1000-SIP10	SIP Supported: Cisco ASR1000-SIP40
4-Port and 8-Port Fast Ethernet SPA	SPA-4X1FE-TX-V2 SPA-8X1FE-TX-V2	Yes	Yes
1-Port 10-Gigabit Ethernet SPA	SPA-1X10GE-L-V2 SPA-1X10GE-L-V2 SPA-1X10GE-L-V2 SPA-1X10GE-L-V2 SPA-1X10GE-L-V2	Yes	Yes
1-Port 10-Gigabit Ethernet LAN/WAN-PHY SPA	SPA-1X10GE-WL-V2	Yes	Yes
2-Port Gigabit Ethernet SPA	SPA-2X1GE-V2	Yes	Yes
5-Port Gigabit Ethernet SPA	SPA-5X1GE-V2	Yes	Yes
8-Port Gigabit Ethernet SPA	SPA-8X1GE-V2	Yes	Yes
10-Port Gigabit Ethernet SPA <sup>1</sup>	SPA-10X1GE-V2	Yes	Yes
2-Port Gigabit Synchronous Ethernet SPA	SPA-2X1GE-SYNCE	Yes	Yes

1. The 10-Port Gigabit Ethernet SPA is a double-height SPA. The 10-Port Gigabit Ethernet SPA is not supported on Cisco ASR 1001, Cisco ASR 1001-X, or Cisco ASR 1002-F Routers.

**Table 1-3 SIP and SPA Compatibility for Packet over SONET SPAs**

<b>SPA</b>	<b>Product ID</b>	<b>SIP Supported: Cisco ASR1000-SIP10</b>	<b>SIP Supported: Cisco ASR1000-SIP40</b>
1-Port OC-12c/STM-4 POS SPA	SPA-1XOC12-POS SPA-1XOC12-POS-V2	Yes	Yes
2-Port, 4-Port, and 8-Port OC-3c/STM-1 POS SPA	SPA-2XOC12-POS SPA-4XOC12-POS SPA-8XOC12-POS	Yes	Yes
2-Port, 4-Port, and 8-Port OC-3c/STM-1 POS SPA	SPA-2XOC3-POS SPA-2XOC3-POS-V2 SPA-4XOC3-POS SPA-4XOC3-POS-V2 SPA-8XOC3-POS	Yes	Yes
1-Port OC-48c/STM-16 POS SPA	SPA-1XOC48-POS	Yes	Yes
2-Port and 4-Port OC-48c/STM-16 POS SPA	SPA-2XOC48POS/RPR SPA-4XOC48POS/RPR	Yes	Yes
1-Port OC-192c/STM-64 POS/RPR XFP SPA	SPA-1XOC192POS-XFP	Yes	Yes

**Table 1-4 SIP and SPA Compatibility for Serial SPAs**

<b>SPA</b>	<b>Product ID</b>	<b>SIP Supported: Cisco ASR1000-SIP10</b>	<b>SIP Supported: Cisco ASR1000-SIP40</b>
2-Port and 4-Port Clear Channel T3/E3 SPA	SPA-2XT3/E3 SPA-2XT3/E3-V2 SPA-4XT3/E3 SPA-4XT3/E3-V2	Yes	Yes
8-Port Clear-Channel T3/E3 Serial SPA	SPA-8XT3/E3	No	Yes
2-Port and 4-Port Channelized T3 SPA	SPA-2XCT3/DS0 SPA-2XCT3/DS0-V2 SPA-4XCT3/DS0 SPA-4XCT3/DS0-V2	Yes	Yes
4-Port Serial Interface SPA	SPA-4XT-Serial	Yes	Yes <sup>1</sup>
8-Port Channelized T1/E1 SPA	SPA-8XCHT1/E1 SPA-8XCHT1/E1-V2	Yes	Yes
1-Port Channelized OC-3/STM-1 SPA	SPA-1XCHSTM1/OC3 SPA-1CHSTM1/OC3V2	Yes	Yes
1-Port Channelized OC-12/STM-4 SPA	SPA-1XCHOC12/DS0	Yes	Yes

1. The SPA-4XT-Serial SPA is supported on SIP-40 with the initial Cisco IOS XE Release 3.1.1S when plugged into an ASR1000 SIP-40 linecard.

**Table 1-5 SIP and SPA Compatibility for Service SPAs**

SPA	Product ID	SIP Supported: Cisco ASR1000-SIP10	SIP Supported: Cisco ASR1000-SIP40
Cisco WebEx Node for ASR 1000 Series	SPA-WMA-K9	Yes	Yes
Cisco DSP SPA for ASR 1000 Series	SPA-DSP	Yes	Yes

**Table 1-6 SIP and SPA Compatibility for CEoP SPA**

SPA	Product ID	SIP Supported: Cisco ASR1000-SIP10	SIP Supported: Cisco ASR1000-SIP40
1-Port Channelized OC3/STM-1 ATM and Circuit Emulation SPA <sup>1</sup>	SPA-1CHOC3-CE-ATM	Yes	Yes
2-Port Channelized T3/E3 ATM CEoP SPA <sup>2</sup>	SPA-2CHT3-CE-ATM	Yes	Yes
24-Port Channelized T1/E1 ATM CEoP SPA <sup>3</sup>	SPA-24CHT1-CE-ATM	Yes	Yes

1. Restriction: The SPA-1CHOC3-CE-ATM is not supported on the Cisco ASR 1001 Router (1 RU chassis), but supported on all other ASR 1000 chassis. All the other ASR 1000 Routers support the SPA-1CHOC3-CE-ATM for Circuit Emulation application; but not ATM applications. Effective from Cisco IOS XE Release 3.3.0S, the SPA-1CHOC3-CE-ATM is supported only with these software images: ADVANCED ENTERPRISE SERVICES, ADVANCED ENTERPRISE W/O CRYPTO, ADVANCED IP SERVICES, or ADVANCED IP SERVICES W/O CRYPTO. The SPA-1CHOC3-CE-ATM is not supported with these software images: IP BASE and IP BASE W/O CRYPTO.
2. Restriction: Effective from Cisco IOS XE Release 3.4.0S, the SPA-2CHT3-CE-ATM is supported on all the Cisco ASR 1000 Series Routers except on the Cisco ASR 1001 Router. However, the SPA-2CHT3-CE-ATM supports only the T3 ATM mode in Cisco IOS XE Release 3.4.0S and not the Circuit Emulation (CEM) mode. Maximum Virtual Circuits supported are 1024. Interim Local Management Interface (ILMI) 1.0 is not supported. IETF RFC 2364 and 2516 for Point-to-Point Protocol (PPP) over ATM is not supported. IETF RFC 1577 support for classical IP and Address Resolution Protocol (ARP) over ATM is not supported. ATM Forum UNI 3.0, 3.1, and 4.0 is not supported. Effective from Cisco IOS XE Release 3.5.0S, the SPA-2CHT3-CE-ATM supports ATM on clear-channel E3 SPA. All the existing ATM features are supported in the E3 mode. Effective from Cisco IOS XE Release 3.8.0S, the SPA-2CHT3-CE-ATM is supported on the Cisco ASR 1001 Router. The SPA-2CHT3-CE-ATM on the Cisco ASR 1001 Router supports both the T3 and E3 ATM modes and does not support the CEM mode.
3. Restriction: The SPA-24CHT1-CE-ATM is not supported on the Cisco ASR 1001 Router (1 RU chassis), but supported on all other ASR 1000 chassis. Effective from Cisco IOS XE Release 3.4.0S, the SPA-24CHT1-CE-ATM supports only the CEM mode. Effective from Cisco IOS XE Release 3.4.0S, the SPA-24CHT1-CE-ATM is supported only with these software images: ADVANCED ENTERPRISE SERVICES, ADVANCED ENTERPRISE W/O CRYPTO, ADVANCED IP SERVICES, or ADVANCED IP SERVICES W/O CRYPTO. The SPA-24CHT1-CE-ATM is not supported with these software images: IP BASE and IP BASE W/O CRYPTO.

# Modular Optics Compatibility

Some SPAs implement small form-factor pluggable (SFP) optical transceivers to provide network connectivity. An SFP module is a transceiver device that mounts into the front panel to provide network connectivity.

Cisco qualifies the SFP modules that can be used with SPAs.

**Note**

The SPAs will only accept the SFP modules listed as supported in this document. An SFP module check is run every time an SFP module is inserted into a SPA and only SFP modules that pass this check will be usable.

The following tables show the types of optics modules that have been qualified for use with a SPA.

For more information about any of the supported transceivers for SPAs in these tables, refer to the Cisco Transceiver Modules site for that module on Cisco.com at:

[http://www.cisco.com/en/US/products/hw/modules/ps5455/prod\\_installation\\_guides\\_list.html](http://www.cisco.com/en/US/products/hw/modules/ps5455/prod_installation_guides_list.html)

**Table 1-7 ATM SPA Optics Compatibility**

SPA	Qualified Optics Modules (Cisco Part Numbers)
SPA-1XOC3-ATM-V2, SPA-3XOC3-ATM-V2	<ul style="list-style-type: none"> <li>• SFP-OC3-MM</li> <li>• SFP-OC3-SR</li> <li>• SFP-OC3-IR1</li> <li>• SFP-OC3-LR1</li> <li>• SFP-OC3-LR2</li> </ul>
SPA-1XOC12-ATM-V2	<ul style="list-style-type: none"> <li>• SFP-OC12-MM</li> <li>• SFP-OC12-SR</li> <li>• SFP-OC12-IR1</li> <li>• SFP-OC12-LR1</li> <li>• SFP-OC12-LR2</li> </ul>

**Table 1-8 10-Gigabit Ethernet Optics Compatibility**

SPA	Qualified Optics Modules (Cisco Part Numbers)
Built-in 10-Gigabit Ethernet Ports (SFP+): ASR1001-X	<ul style="list-style-type: none"> <li>• SFP-10G-SR</li> <li>• SFP-10G-LR</li> <li>• SFP-10G-ER</li> <li>• SFP-10G-BXD-I</li> <li>• SFP-10G-BXU-I</li> <li>• SFP-10G-BX40D-I</li> <li>• SFP-10G-BX40U-I</li> <li>• SFP-10G-SR-X</li> <li>• SFP-10G-LR-X</li> <li>• SFP-H10GB-ACU7M</li> <li>• SFP-H10GB-ACU10M</li> <li>• SFP-10G-SR-S (XE 16.6.1)</li> <li>• SFP-10G-LR-S (XE 16.6.1)</li> <li>• SFP-10G-ER-S (XE 16.6.1)</li> <li>• SFP-10G-AOC 1-10M (XE 16.6.1)</li> </ul>

**Table 1-8 10-Gigabit Ethernet Optics Compatibility**

<p>Built-in 10-Gigabit Ethernet Ports (SFP+): ASR1001-HX, ASR1002-HX</p>	<ul style="list-style-type: none"> <li>• SFP-10G-SR</li> <li>• SFP-10G-LR</li> <li>• SFP-10G-ER</li> <li>• SFP-10G-ZR</li> <li>• SFP-10G-BXD-I</li> <li>• SFP-10G-BXU-I</li> <li>• SFP-10G-BX40D-I</li> <li>• SFP-10G-BX40U-I</li> <li>• SFP-10G-SR-X</li> <li>• SFP-10G-LR-X</li> <li>• SFP-H10GB-ACU7M</li> <li>• SFP-H10GB-ACU10M</li> <li>• DWDM (non-tunable)</li> <li>• SFP-10G-SR-S (XE 16.6.1)</li> <li>• SFP-10G-LR-S (XE 16.6.1)</li> <li>• SFP-10G-ER-S (XE 16.6.1)</li> <li>• SFP-10G-ZR-S (XE 16.6.1)</li> <li>• SFP-10G-AOC 1-10M (XE 16.6.1)</li> </ul> <p><b>Note</b> These ports utilize the SFP+ form factor optics, while the 1-Port 10-Gigabit Ethernet SPA uses the XFP form factor optics.</p>
--	--



**Table 1-8 10-Gigabit Ethernet Optics Compatibility**

EPA-10X10GE (SFP+)	<ul style="list-style-type: none"> <li>• SFP-10G-SR</li> <li>• SFP-10G-LR</li> <li>• SFP-10G-ER</li> <li>• SFP-10G-ZR</li> <li>• SFP-10G-BXD-I</li> <li>• SFP-10G-BXU-I</li> <li>• SFP-10G-BX40D-I</li> <li>• SFP-10G-BX40U-I</li> <li>• SFP-10G-SR-X</li> <li>• SFP-10G-LR-X</li> <li>• SFP-H10GB-ACU7M</li> <li>• SFP-H10GB-ACU10M</li> <li>• DWDM (non-tunable)</li> <li>• SFP-10G-SR-S (Cisco IOS XE 16.6.1)</li> <li>• SFP-10G-LR-S (Cisco IOS XE 16.6.1)</li> <li>• SFP-10G-ER-S (Cisco IOS XE 16.6.1)</li> <li>• SFP-10G-ZR-S (Cisco IOS XE 16.6.1)</li> <li>• SFP-10G-AOC 1-10M (Cisco IOS XE 16.6.1)</li> </ul>
SPA-1X10GE-L-V2, SPA-1X10GE-WL-V2 (XFP)	<ul style="list-style-type: none"> <li>• XFP-10GER-192IR+</li> <li>• XFP10GER-192IR-L</li> <li>• XFP10GLR-192SR-L</li> <li>• XFP-10GLR-OC192SR</li> <li>• XFP-10GER-OC192IR</li> <li>• XFP-10GZR-OC192LR</li> <li>• XFP-10G-MM-SR</li> <li>• DWDM-XFP-C</li> </ul>
ASR1000-2T+20X1GE, ASR1000-6TGE (XFP)	<ul style="list-style-type: none"> <li>• XFP-10GER-192IR+</li> <li>• XFP10GER-192IR-L</li> <li>• XFP10GLR-192SR-L</li> <li>• XFP-10GLR-OC192SR</li> <li>• XFP-10GER-OC192IR</li> <li>• XFP-10GZR-OC192LR</li> <li>• XFP-10G-MM-SR</li> <li>• DWDM-XFP-C</li> </ul>

**Table 1-9 40-Gigabit Ethernet Optics Compatibility**

SPA	Qualified Optics Modules (Cisco Part Numbers)
EPA-CPAK-2X40GE	CPAK-100G-SR10 + CAB-MPO24-2XMPO12

**Table 1-10 100-Gigabit Ethernet Optics Compatibility**

SPA	Qualified Optics Modules (Cisco Part Numbers)
EPA-1X100GE	<ul style="list-style-type: none"> <li>• CPAK-100G-SR10</li> <li>• CPAK-100G-LR4</li> </ul>



**Table 1-11 Gigabit Ethernet Optics Compatibility**

<b>SPA</b>	<b>Qualified Optics Modules (Cisco Part Numbers)</b>
Built-in Gigabit Ethernet Ports  ASR1001, ASR1001-X, ASR1002, ASR1002, ASR1002-X	<ul style="list-style-type: none"> <li>• SFP-GE-S</li> <li>• SFP-GE-L</li> <li>• SFP-GE-T</li> <li>• GLC-TE</li> <li>• SFP-GE-Z</li> <li>• GLC-BX-D</li> <li>• GLC-BX-U</li> <li>• GLC-BX40-D-I</li> <li>• GLC-BX40-DA-I</li> <li>• GLC-BX40-U-I</li> <li>• GLC-BX80-D-I</li> <li>• GLC-BX80-U-I</li> <li>• GLC-GE-100FX=</li> <li>• GLC-SX-MM</li> <li>• GLC-SX-MMD</li> <li>• GLC-LH-SM</li> <li>• GLC-LH-SMD</li> <li>• GLC-EX-SMD</li> <li>• GLC-ZX-SMD</li> <li>• DWDM</li> <li>• CWDM</li> </ul>

**Table 1-11 Gigabit Ethernet Optics Compatibility**

<b>SPA</b>	<b>Qualified Optics Modules (Cisco Part Numbers)</b>
Built-in Gigabit Ethernet Ports ASR1001-HX, ASR1002-HX	<ul style="list-style-type: none"> <li>• SFP-GE-T</li> <li>• GLC-TE</li> <li>• GLC-BX-D</li> <li>• GLC-BX-U</li> <li>• GLC-BX40-D-I</li> <li>• GLC-BX40-DA-I</li> <li>• GLC-BX40-U-I</li> <li>• GLC-BX80-D-I</li> <li>• GLC-BX80-U-I</li> <li>• GLC-GE-100FX=</li> <li>• GLC-SX-MM</li> <li>• GLC-SX-MMD</li> <li>• GLC-LH-SM</li> <li>• GLC-LH-SMD</li> <li>• GLC-EX-SMD</li> <li>• GLC-ZX-SMD</li> <li>• DWDM</li> <li>• CWDM</li> </ul>

**Table 1-11 Gigabit Ethernet Optics Compatibility**

<b>SPA</b>	<b>Qualified Optics Modules (Cisco Part Numbers)</b>
SPA-2X1GE-V2, SPA-8X1GE-V2	<ul style="list-style-type: none"> <li>• SFP-GE-S</li> <li>• SFP-GE-L</li> <li>• SFP-GE-T</li> <li>• GLC-TE</li> <li>• SFP-GE-Z</li> <li>• GLC-BX-D</li> <li>• GLC-BX-U</li> <li>• GLC-BX40-D-I</li> <li>• GLC-BX40-DA-I</li> <li>• GLC-BX40-U-I</li> <li>• GLC-BX80-D-I</li> <li>• GLC-BX80-U-I</li> <li>• GLC-LH-SMD</li> <li>• GLC-SX-MMD</li> <li>• GLC-EX-SMD</li> <li>• GLC-ZX-SMD</li> <li>• DWDM</li> <li>• CWDM</li> </ul>

**Table 1-11 Gigabit Ethernet Optics Compatibility**

SPA	Qualified Optics Modules (Cisco Part Numbers)
SPA-5X1GE-V2, SPA-10X1GE-V2	<ul style="list-style-type: none"> <li>• SFP-GE-S</li> <li>• SFP-GE-L</li> <li>• SFP-GE-T</li> <li>• GLC-TE</li> <li>• SFP-GE-Z</li> <li>• GLC-BX-D</li> <li>• GLC-BX-U</li> <li>• GLC-BX40-D-I</li> <li>• GLC-BX40-DA-I</li> <li>• GLC-BX40-U-I</li> <li>• GLC-BX80-D-I</li> <li>• GLC-BX80-U-I</li> <li>• GLC-GE-100FX=</li> <li>• GLC-LH-SMD</li> <li>• GLC-SX-MMD</li> <li>• GLC-EX-SMD</li> <li>• GLC-ZX-SMD</li> <li>• DWDM</li> <li>• CWDM</li> </ul>
SPA-2X1GE-SYNCE	<ul style="list-style-type: none"> <li>• SFP-GE-S</li> <li>• SFP-GE-L</li> <li>• GLC-TE</li> <li>• SFP-GE-Z</li> <li>• GLC-BX-D</li> <li>• GLC-BX-U</li> <li>• GLC-LH-SMD</li> <li>• GLC-SX-MMD</li> <li>• GLC-EX-SMD</li> <li>• GLC-ZX-SMD</li> </ul> <p data-bbox="954 1667 1403 1724"><b>Note</b> The SPA-2X1GE-SYNCE is not supported on ASR1002-X.</p>

Table 1-11 Gigabit Ethernet Optics Compatibility

SPA	Qualified Optics Modules (Cisco Part Numbers)
ASR1000-2T+20X1GE	<ul style="list-style-type: none"> <li>• SFP-GE-S</li> <li>• SFP-GE-L</li> <li>• SFP-GE-T</li> <li>• GLC-TE</li> <li>• SFP-GE-Z</li> <li>• GLC-BX-D</li> <li>• GLC-BX-U</li> <li>• GLC-BX40-D-I</li> <li>• GLC-BX40-DA-I</li> <li>• GLC-BX40-U-I</li> <li>• GLC-BX80-D-I</li> <li>• GLC-BX80-U-I</li> <li>• GLC-GE-100FX=</li> <li>• GLC-LH-SMD</li> <li>• GLC-SX-MMD</li> <li>• GLC-EX-SMD</li> <li>• GLC-ZX-SMD</li> <li>• DWDM</li> <li>• CWDM</li> </ul>



**Table 1-11 Gigabit Ethernet Optics Compatibility**

SPA	Qualified Optics Modules (Cisco Part Numbers)
EPA-18X1GE	<ul style="list-style-type: none"> <li>• SFP-GE-T</li> <li>• GLC-TE</li> <li>• GLC-BX-D</li> <li>• GLC-BX-U</li> <li>• GLC-BX40-D-I</li> <li>• GLC-BX40-DA-I</li> <li>• GLC-BX40-U-I</li> <li>• GLC-BX80-D-I</li> <li>• GLC-BX80-U-I</li> <li>• GLC-GE-100FX=</li> <li>• GLC-LH-SMD</li> <li>• GLC-SX-MMD</li> <li>• GLC-EX-SMD</li> <li>• GLC-ZX-SMD</li> <li>• DWDM</li> <li>• CWDM</li> </ul>

**Table 1-12 Gigabit Ethernet SPA Optics Compatibility**

SPA	Qualified Optics Modules (Cisco Part Numbers)
Fixed Ethernet Line Card, 2x10GE + 20x1GE, Fixed Ethernet Line Card, 6x10GE	<ul style="list-style-type: none"> <li>• XFP-10GER-192IR+</li> <li>• XFP10GER-192IR-L</li> <li>• XFP10GLR-192SR-L</li> <li>• XFP-10GLR-OC192SR</li> <li>• XFP-10GER-OC192IR</li> <li>• XFP-10GZR-OC192LR</li> <li>• XFP-10G-MM-SR</li> <li>• DWDM-XFP-C</li> </ul>

**Table 1-13** CWDM Optics Compatibility on the Cisco ASR 1000 Series Routers

<b>SPA</b>	<b>Qualified Optics Modules (Cisco Part Numbers)</b>
<p>Built-in Gigabit Ethernet Ports: ASR1001, ASR1001-X, ASR1002, ASR1002-X, ASR1001-HX, ASR1002-HX</p> <p>SPA-2X1GE-V2, SPA-5X1GE-V2, SPA-8X1GE-V2, SPA-10X1GE-V2</p> <p>EPA-18X1GE</p>	<ul style="list-style-type: none"> <li>• CWDM-SFP-1470=</li> <li>• CWDM-SFP-1490=</li> <li>• CWDM-SFP-1510=</li> <li>• CWDM-SFP-1530=</li> <li>• CWDM-SFP-1550=</li> <li>• CWDM-SFP-1570=</li> <li>• CWDM-SFP-1590=</li> <li>• CWDM-SFP-1610=</li> </ul>

**Table 1-14 DWDM Optics Compatibility for Gigabit Ethernet Ports on the Cisco ASR 1000 Series Routers**

SPA	Qualified Optics Modules (Cisco Part Numbers)
Built-in Gigabit Ethernet Ports: ASR1001, ASR1001-X, ASR1002, ASR1002-X, ASR1001-HX, ASR1002-HX	<ul style="list-style-type: none"> <li>• DWDM-SFP-3033=</li> <li>• DWDM-SFP-3112=</li> <li>• DWDM-SFP-3190=</li> </ul>
SPA-2X1GE-V2, SPA-5X1GE-V2, SPA-8X1GE-V2, SPA-10X1GE-V2	<ul style="list-style-type: none"> <li>• DWDM-SFP-3268=</li> <li>• DWDM-SFP-3425=</li> <li>• DWDM-SFP-3504=</li> </ul>
EPA-18X1GE	<ul style="list-style-type: none"> <li>• DWDM-SFP-3582=</li> <li>• DWDM-SFP-3661=</li> <li>• DWDM-SFP-3819=</li> <li>• DWDM-SFP-3898=</li> <li>• DWDM-SFP-3977=</li> <li>• DWDM-SFP-4056=</li> <li>• DWDM-SFP-4214=</li> <li>• DWDM-SFP-4294=</li> <li>• DWDM-SFP-4373=</li> <li>• DWDM-SFP-4453=</li> <li>• DWDM-SFP-4612=</li> <li>• DWDM-SFP-4692=</li> <li>• DWDM-SFP-4772=</li> <li>• DWDM-SFP-4851=</li> <li>• DWDM-SFP-5012=</li> <li>• DWDM-SFP-5092=</li> <li>• DWDM-SFP-5172=</li> <li>• DWDM-SFP-5252=</li> <li>• DWDM-SFP-5413=</li> <li>• DWDM-SFP-5494=</li> <li>• DWDM-SFP-5575=</li> <li>• DWDM-SFP-5655=</li> <li>• DWDM-SFP-5817=</li> <li>• DWDM-SFP-5898=</li> <li>• DWDM-SFP-5979=</li> <li>• DWDM-SFP-6061=</li> </ul>

**Table 1-15 POS SPA SFP Optics Compatibility**

<b>SPA</b>	<b>Qualified Optics Modules (Cisco Part Numbers)</b>
SPA-2XOC3-POS, SPA-2XOC3-POS-V2, SPA-4XOC3-POS, SPA-4XOC3-POS-V2, SPA-8XOC3-POS	<ul style="list-style-type: none"> <li>• SFP-OC3-MM</li> <li>• SFP-OC3-SR</li> <li>• SFP-OC3-IR1</li> <li>• SFP-OC3-LR1</li> <li>• SFP-OC3-LR2</li> </ul>
SPA-1XOC12-POS-V2, SPA-2XOC12-POS	<ul style="list-style-type: none"> <li>• SFP-OC12-MM</li> <li>• SFP-OC12-SR</li> <li>• SFP-OC12-IR1</li> <li>• SFP-OC12-LR1</li> <li>• SFP-OC12-LR2</li> </ul>
2-Port and 4-Port OC-48c/STM-16 POS SPA	<ul style="list-style-type: none"> <li>• SFP-OC48-SR</li> <li>• SFP-OC48-IR1</li> <li>• SFP-OC48-LR2</li> </ul>
SPA-1XOC48-POS, SPA-2XOC48POS/RPR, SPA-4XOC48POS/RPR	<ul style="list-style-type: none"> <li>• SFP-OC48-SR</li> <li>• SFP-OC48-IR1</li> <li>• SFP-OC48-LR2</li> </ul>
SPA-1XOC192POS-XFP	<ul style="list-style-type: none"> <li>• XFP10GER-192IR-L</li> <li>• XFP10GLR-192SR-L</li> <li>• XFP-10GLR-OC192SR</li> <li>• XFP-10GER-OC192IR</li> <li>• XFP-10GZR-OC192LR</li> </ul>

**Table 1-16 Serial SPA SFP Optics Compatibility**

<b>SPA</b>	<b>Qualified Optics Modules (Cisco Part Numbers)</b>
SPA-1XCHSTM1/OC3, SPA-1CHSTM1/OC3V2	<ul style="list-style-type: none"> <li>• SFP-OC3-MM</li> <li>• SFP-OC3-SR</li> <li>• SFP-OC3-IR1</li> <li>• SFP-OC3-LR1</li> <li>• SFP-OC3-LR2</li> </ul>
SPA-1XCHOC12/DS0	<ul style="list-style-type: none"> <li>• SFP-OC12-MM</li> <li>• SFP-OC12-SR</li> <li>• SFP-OC12-IR1</li> <li>• SFP-OC12-LR1</li> <li>• SFP-OC12-LR2</li> </ul>

**Table 1-17** CCoP SPA SFP Optics Compatibility

<b>SPA</b>	<b>Qualified Optics Modules (Cisco Part Numbers)</b>
1SPA-1CHOC3-CE-ATM	<ul style="list-style-type: none"> <li>• SFP-OC3-MM</li> <li>• SFP-OC3-SR</li> <li>• SFP-OC3-IR1</li> <li>• SFP-OC3-LR1</li> <li>• SFP-OC3-LR2</li> </ul>
SPA-2CHT3-CE-ATM	<ul style="list-style-type: none"> <li>• CAB-T3E3-RF-BNC-M</li> <li>• CAB-T3E3-RF-BNC-F</li> <li>• CAB-T3E3-RF-OPEN</li> </ul>
SPA-24CHT1-CE-ATM	<ul style="list-style-type: none"> <li>• CABLE-24T1E1</li> </ul>





# Overview: Cisco ASR 1000 Series Aggregation Services Routers SIPs

This chapter describes the SPA interface processors (SIPs) that are supported on the Cisco ASR 1000 Series Aggregation Services Routers and contains the following sections:

- [SIP Summary, page 2-1](#)
- [SPA Interface Addresses on SIPs, page 2-3](#)
- [Identifying Slots and Subslots for SIPs and SPAs, page 2-3](#)
- [Cisco ASR 1000 Series SPA Interface Processor Overview, page 2-7](#)

## SIP Summary

Summary descriptions of the SIPs that are supported on the Cisco ASR 1000 Series Routers are shown in [Table 2-1](#).



**Note**

The Description column indicates the aggregate bandwidth supported by the SIP across all subslots, and not per SPA subslot.

**Table 2-1** SIP Summary

SIP	Product Number	Description	Maximum Number of SPAs	Minimum Cisco IOS Release
Cisco ASR 1000 Series SIP10G	ASR-1000-SIP10	10 Gbps SPA interface processor	4	Cisco IOS XE Release 2.2
Cisco ASR 1000 Series SIP40G	ASR-1000-SIP40	40 Gbps SPA interface processor	4 <sup>1</sup>	Cisco IOS XE Release 3.1S

1. The Cisco ASR1000-SIP40 carrier card supports four half-height SPAs, two full-height SPAs, or a combination of two half-height and one full-height SPAs. Double-wide SPAs are not supported.

## Checking Hardware and Software Compatibility

To check the minimum software requirements of Cisco IOS software with the hardware installed on your router, Cisco maintains the Software Advisor tool on Cisco.com. This tool does not verify whether SIPs or SPAs within a system are compatible, but it does provide the minimum Cisco IOS requirements for individual hardware modules or components.



**Note**

Access to this tool is limited to users with Cisco.com login accounts.

To access Software Advisor, click **Login** at Cisco.com, type “Software Advisor” in the SEARCH box, and click **GO**. Click the link for the Software Advisor tool.

Choose a product family or enter a specific product number to search for the minimum supported software release needed for your hardware. For details regarding the hardware and software supported for ASR1000 SIPs, refer [Table 2-2](#).



**Note**

The Cisco ASR 1002-X Router has an integrated route processor, embedded services processor, and SIP.

**Table 2-2** Hardware and Software Support Matrix for ASR1000 SIPs

SIP Type	Cisco IOS XE Software Release	Supported Route Processor	Supported ESP	Supported Cisco ASR 1000 Router Chassis
ASR1000-SIP10	Cisco IOS XE Release 2	ASR1000-RP1 and ASR1000-RP2	ASR1000-ESP10, ASR1000-ESP10-N, ASR1000-ESP20, ASR1000-ESP40, and ASR1000-ESP100  <b>Note</b> ASR1000-ESP100 is supported only on routers on which ASR1000-RP2 is installed.	Cisco ASR1002, Cisco ASR 1002-F, Cisco ASR 1004, Cisco ASR 1006, and Cisco ASR 1013 Routers
ASR1000-SIP40 <sup>1</sup>	Cisco IOS XE Release 3.1S	ASR1000-RP2 and later RPs	ASR1000-ESP10, ASR1000-ESP10-N, ASR1000-ESP20, ASR1000-ESP40, and ASR1000-ESP100  ASR1000-ESP100 is supported only on routers on which ASR1000-RP2 is installed.	Cisco ASR 1002-X, Cisco ASR 1004, Cisco ASR 1006, and Cisco ASR 1013 Routers <sup>2</sup>
ASR1000-SIP40	Cisco IOS XE Release 3.2S	ASR1000-RP2 and later RPs	Primarily supported only on ASR1000-ESP40 <sup>3</sup>	Cisco ASR 1004 Routers

1. ASR1000-SIP40 when used with ESP20, it comes up in SIP10 mode with 10 Gbps throughput.

2. The Cisco ASR 1013 Router has limitation to support ASR1000-SIP40 at slots 4 and 5 at 40G mode. If a ASR1000-SIP40 is installed at slots 4 or 5, it will work as a SIP10 at 10G mode.



3. Support for ASR1000-SIP40 and ASR1000-ESP40 added on Cisco ASR 1004 Router Chassis from Cisco IOS XE Release 3.2S and future releases.

## SPA Interface Addresses on SIPs

Interface addresses specify the physical location of each interface on a router or switch. [Table 2-3](#) describes how to identify the interface addresses for SPAs supported on the SIPs.

**Table 2-3** SPA Interface Addresses

SIP	Address Format	Description
Cisco ASR 1000 Series SIP	<i>router-module-slot/SIP-subslot/SPA-port-number</i>	Router module slot—0 through 2 SIP subslot—0 through 3 SPA port number—0 through x <b>Note</b> The maximum number of SPA ports depends on the type of SPA.

## Identifying Slots and Subslots for SIPs and SPAs

This section describes how to specify the physical locations of a SIP and SPA on the Cisco ASR 1000 Series Routers within the command-line interface (CLI) to configure or monitor the devices.

### Specifying the Slot Location for a SIP

The Cisco ASR 1000 Series Routers support different chassis models, each of which supports a certain number of chassis slots.

- The Cisco ASR 1013 Router supports six chassis slots for SIPs.
- The Cisco ASR 1006 Router supports three chassis slots for SIPs.
- The Cisco ASR 1004 Router supports two chassis slots for SIPs.
- The Cisco ASR 1002 Router and Cisco ASR 1002-X Router support one chassis slot for a SIP that is permanently installed, and the integrated Route Processor and Gigabit Ethernet ports reside in SPA subslot 0.

Figure 2-1 shows an example of a SIP installed on a Cisco ASR 1006 Router. The router has three chassis slots for SIPs, and can accommodate a total of twelve SPAs.

Figure 2-1 SIP and SPAs Installed in a Cisco ASR 1006 Router



231512

Some commands allow you to display information about the SIP itself, such as **show platform**, **show diag**, and **show diag subslot**. These commands require you to specify the chassis slot location where the SIP that you want information about is installed.

For example, to display status and slot-related information about the SIP installed in any of the chassis slots, enter the following command:

```
Router# show platform
Chassis type: ASR1006
```

Slot	Type	State	Insert time (ago)
0	ASR1000-SIP10	ok	2d21h
0/0	SPA-2X1GE-V2	ok	2d21h
0/1	SPA-2X1GE-V2	ok	2d21h
0/2	SPA-2X1GE-V2	ok	2d21h
0/3	SPA-1XOC12-POS	ok	2d21h
1	ASR1000-SIP10	ok	22:46:22
1/0	SPA-1X10GE-L-V2	ok	22:45:29
1/1	SPA-1XOC12-POS	ok	22:45:26
1/2	SPA-1X10GE-L-V2	ok	22:45:22
1/3	SPA-1XOC12-POS	ok	22:45:18
2	ASR1000-SIP10	ok	1d20h
2/0	SPA-5X1GE-V2	ok	1d20h
2/1	SPA-5X1GE-V2	ok	1d20h
2/2	SPA-5X1GE-V2	ok	1d20h
2/3	SPA-5X1GE-V2	ok	1d20h
R0	ASR1000-RP1	ok, active	3d20h
F0	ASR1000-ESP10	ok, active	3d20h
P0	ASR1006-PWR-AC	ok	3d20h

```
P1 ASR1006-FAN ok 3d20h
```

```
Slot CPLD Version Firmware Version
-----
0 07091401 12.2(33r)XN2
1 07091401 12.2(33r)XN2
2 07091401 12.2(33r)XN2
R0 07082312 12.2(33r)XN2
```

The following example shows the **show platform** command output for the ASR 1013 chassis with Cisco ASR1000-SIP10 and Cisco ASR1000-SIP40 installed:

```
Router# show platform
Chassis type: ASR1013
```

```
Slot Type State Insert time (ago)
-----
0 ASR1000-SIP10 ok 1w0d
1 ASR1000-SIP40 ok 1w0d
 1/1 SPA-5X1GE-V2 ok 1w0d
2 ASR1000-SIP40 ok 1w0d
 2/1 SPA-1X10GE-L-V2 ok 1w0d
 2/3 SPA-1X10GE-L-V2 ok 1w0d
3 ASR1000-SIP40 ok 1w0d
 3/3 SPA-4XT3/E3 ok 1w0d
4 ASR1000-SIP40 ok 1w0d
 4/2 SPA-5X1GE-V2 ok 1w0d
 4/3 SPA-4XCT3/DS0 ok 1w0d
5 ASR1000-SIP40 ok 1w0d
R0 ASR1000-RP2 ok, active 1w0d
R1 ASR1000-RP2 ok, standby 1w0d
F0 ASR1000-ESP40 ok, active 1w0d
P0 ASR1013-PWR-AC ok 1w0d
P1 ASR1013-PWR-AC ps, fail 1w0d
P2 ASR1013-PWR-AC ok 1w0d
P3 ASR1013-PWR-AC ps, fail 1w0d

Slot CPLD Version Firmware Version
-----
0 00200800 15.0(1r)S
1 00200800 15.0(1r)S
2 00200800 15.0(1r)S
3 00200800 15.0(1r)S
4 00200800 15.0(1r)S
5 00200800 15.0(1r)S
R0 10021901 15.0(1r)S
R1 10021901 15.0(1r)S
F0 1001270D 15.0(1r)S
```

## Specifying the SIP Subslot Location for a SPA

SIP subslots begin their numbering with “0” and have a horizontal orientation, as shown in the “SIP and SPA Product Overview” chapter of the *Cisco ASR 1000 Series Aggregation Services Routers SIP and SPA Software Configuration Guide*.

The Cisco ASR 1000 series SIP supports four subslots for the installation of SPAs. As shown in [Figure 2-2](#), the subslot locations are oriented as follows:

- SIP subslot 0—Top-left subslot
- SIP subslot 1—Top-right subslot

- SIP subslot 2—Bottom-left subslot
- SIP subslot 3—Bottom-right subslot

**Note**

On the Cisco ASR 1002 Router and Cisco ASR 1002-X Router, SIP subslot 0 is not available for SPA insertion. It is the slot that is used for the integrated Route Processor and Gigabit Ethernet ports.

Figure 2-2 shows the SPA numbering sequence on a Cisco ASR 1000 Series Routers SIP.

**Figure 2-2** Cisco ASR 1000 Series SIP SPA Numbering

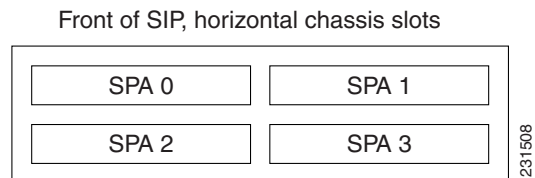

The SIP subslot numbering is indicated by a small numeric label beside the subslot on the faceplate.

Just as with the SIPs, some commands allow you to display information about the SPA itself, such as **show diag subslot**. These commands require you to specify both the physical location of the SIP and SPA in the format, *slot/subslot*, where:

- *slot*—Specifies the chassis slot number in the Cisco ASR 1000 Series Routers where the SIP is installed.
- *subslot*—Specifies the slot of the SIP where the SPA is installed.

To display the operational status for a SPA installed in the SIP, enter the **show platform** command.

```
Router# show platform
Chassis type: ASR1006
```

Slot	Type	State	Insert time (ago)
0	ASR1000-SIP10	ok	2d21h
0/0	SPA-2X1GE-V2	ok	2d21h
0/1	SPA-2X1GE-V2	ok	2d21h
0/2	SPA-2X1GE-V2	ok	2d21h
0/3	SPA-1XOC12-POS	ok	2d21h
1	ASR1000-SIP10	ok	22:46:22
1/0	SPA-1X10GE-L-V2	ok	22:45:29
1/1	SPA-1XOC12-POS	ok	22:45:26
1/2	SPA-1X10GE-L-V2	ok	22:45:22
1/3	SPA-1XOC12-POS	ok	22:45:18
2	ASR1000-SIP10	ok	1d20h
2/0	SPA-5X1GE-V2	ok	1d20h
2/1	SPA-5X1GE-V2	ok	1d20h
2/2	SPA-5X1GE-V2	ok	1d20h
2/3	SPA-5X1GE-V2	ok	1d20h
R0	ASR1000-RP1	ok, active	3d20h
F0	ASR1000-ESP10	ok, active	3d20h
P0	ASR1006-PWR-AC	ok	3d20h
P1	ASR1006-FAN	ok	3d20h

Slot	CPLD Version	Firmware Version
0	07091401	12.2(33r)XN2
1	07091401	12.2(33r)XN2
2	07091401	12.2(33r)XN2

```
R0      07082312      12.2(33r)XN2
```

The following is a **show platform** command output example displaying the status of the DSP SPA installed on a Cisco ASR 1000 Series Routers:

```
Router# show platform
Chassis type: ASR1004
```

Slot	Type	State	Insert time (ago)
1	ASR1000-SIP10	ok	00:14:53
1/0	SPA-10X1GE-V2	ok	00:12:51
1/3	SPA-DSP	ok	00:12:47
R0	ASR1000-RP1	ok, active	00:14:53
F0	ASR1000-ESP10	ok, active	00:14:53
P0	ASR1004-PWR-AC	ps, fail	00:14:04
P1	ASR1004-PWR-AC	ok	00:14:03

Slot	CPLD Version	Firmware Version
1	07091401	12.2(33r)XN2
R0	07062111	12.2(33r)XN2
F0	07051650	12.2(33r)XN2

## Cisco ASR 1000 Series SPA Interface Processor Overview

This section provides an overview of the SPA Interface Processor (SIP) supported on the Cisco ASR 1000 Series Routers. This section contains the following topics:

- [Cisco ASR1000-SIP10 Overview, page 2-7](#)
- [Cisco ASR1000-SIP40 Overview, page 2-9](#)

### Cisco ASR1000-SIP10 Overview

The following sections describe the Cisco ASR1000-SIP10:

- [Cisco ASR1000-SIP10 LEDs, page 2-8](#)
- [Cisco ASR1000-SIP10 Physical Specifications, page 2-8](#)

## Cisco ASR1000-SIP10 LEDs

The Cisco ASR1000-SIP10 has two LEDs, as shown in [Figure 2-3](#).

**Figure 2-3** Cisco ASR1000-SIP10 Faceplate

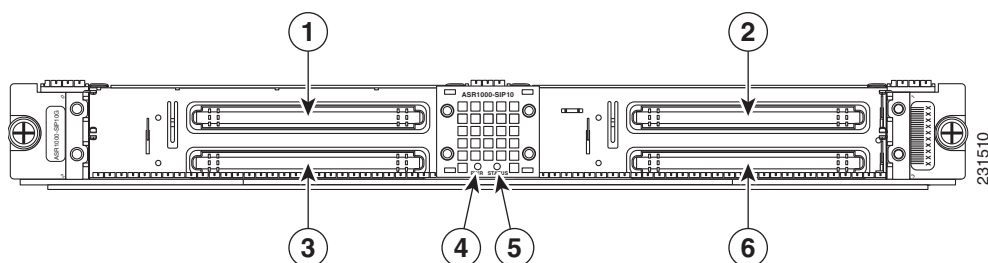

1	SPA, subslot 0	4	PWR LED
2	SPA, subslot 1	5	STATUS LED
3	SPA, subslot 2	6	SPA, subslot 3

The Cisco ASR1000-SIP10 LEDs are described in [Table 2-4](#).

**Table 2-4** Cisco ASR1000-SIP10 LEDs

LED Label	Color	State	Meaning
STATUS	Red	On	The Cisco ASR1000-SIP10 has encountered an error.
	Yellow	On	The Cisco ASR1000-SIP10 is loading.
	Green	On	The Cisco ASR1000-SIP10 is online.
	Off	Off	The Cisco ASR1000-SIP10 is powered off.
PWR	Green	On	The Cisco ASR1000-SIP10 is powered on.
	Off	Off	The Cisco ASR1000-SIP10 is powered off.

## Cisco ASR1000-SIP10 Physical Specifications

The Cisco ASR1000-SIP10 physical specifications are described in [Table 2-5](#).

**Table 2-5** Cisco ASR1000-SIP10 Physical Specifications

Description	Specifications
Physical dimension (HxWxD)	1.630 inches (41.4 mm) x 16.725 inches (424.8 mm) x 14.187 inches (360.3 mm)
Shipping weight	8.5 lb (3.9 kg)
Operating temperature	Nominal—40.9°F to 104°F (5 to 40°C) Short Term—40.9°F to 131°F (5 to 55°C)

Table 2-5 Cisco ASR1000-SIP10 Physical Specifications (continued)

Description	Specifications
Relative humidity	Operating Humidity Nominal—5% to 85% noncondensing Operating Humidity Short Term—5% to 90% noncondensing
Storage temperature	–40°F to 158°F (–40°C to 70°C)

## Cisco ASR1000-SIP40 Overview

The Cisco ASR1000-SIP40 supports up to 40 Gbps total bandwidth for the four SPA bays and 46 Gbps sustained through carrier card when utilizing two four-link 6.25GHz ESIs. Following are the features of the Cisco ASR1000-SIP40:

- Supports 40 Gbps of non oversubscribed throughput.
- Compatible with existing and future SPAs, ESPs, and RPs.
- Supports online-insertion-and-removal (OIR) of all SIP-10 SPAs and Cisco ASR1000-SIP40.
- Provides higher port density support of 48 point dual priority, and 96 point single priority.
- Enables enhanced QoS and timestamp support.
- Performs ingress packet prioritization based on Layer 2 or Layer 3 headers.
- Enables the flow-control of the SPAs.
- Distributes line clocking reference from a single SPA to the RPs.
- From Release 3.7.0S onward, the Cisco ASR1000-SIP40 is supported on all the routers that support the Cisco ASR1000-SIP10.



### Note

The Cisco ASR1000-SIP40 supports four half-height SPAs, two full-height SPAs, and a combination of two half-height and one full-height SPAs. The Cisco ASR1000-SIP40 does not support double-wide SPAs, and double-high SPAs having two connectors.

The LEDs on the modules are the same for both the Cisco ASR1000-SIP10 and Cisco ASR1000-SIP40.

The following sections describe the Cisco ASR1000-SIP40:

- [Cisco ASR1000-SIP40 LEDs](#)
- [Cisco ASR1000-SIP40 Physical Specifications](#)

## Cisco ASR1000-SIP40 LEDs

The Cisco ASR1000-SIP40 has two LEDs, as shown in [Figure 2-4](#).

**Figure 2-4** Cisco ASR1000-SIP40 Faceplate

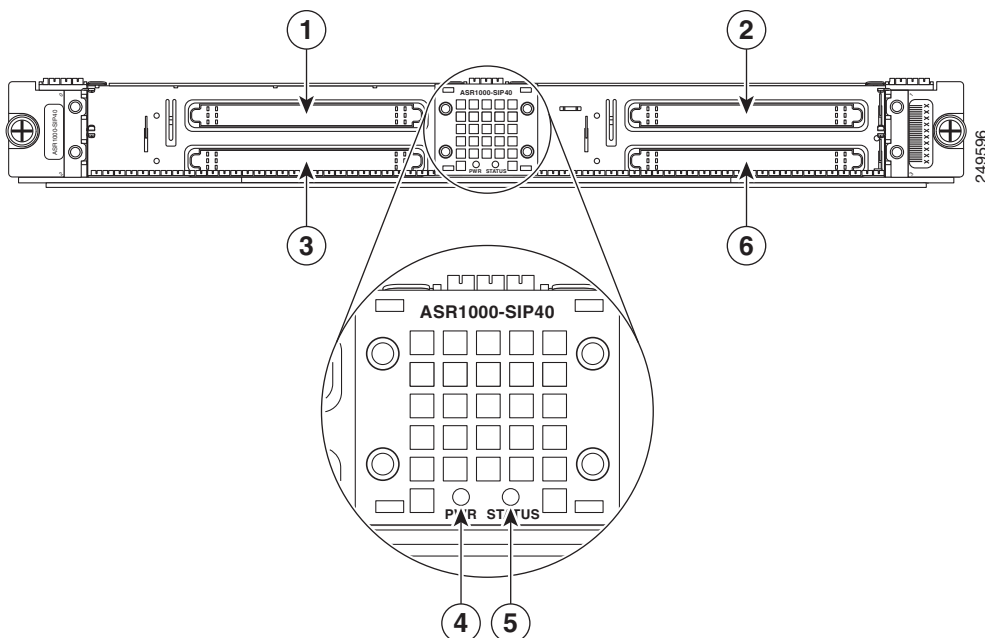

1	SPA, subslot 0	4	PWR LED
2	SPA, subslot 1	5	STATUS LED
3	SPA, subslot 2	6	SPA, subslot 3

The Cisco ASR1000-SIP40 LEDs are described in [Table 2-6](#).

**Table 2-6** Cisco ASR1000-SIP40 LEDs

LED Label	Color	State	Meaning
STATUS	Red	On	The Cisco ASR1000-SIP40 has encountered an error.
	Yellow	On	The Cisco ASR1000-SIP40 is loading.
	Green	On	The Cisco ASR1000-SIP40 is online.
	Off	Off	The Cisco ASR1000-SIP40 is powered off.
PWR	Green	On	The Cisco ASR1000-SIP40 is powered on.
	Off	Off	The Cisco ASR1000-SIP40 is powered off.



## Cisco ASR1000-SIP40 Physical Specifications

The Cisco ASR1000-SIP40 physical specifications are shown in [Table 2-7](#).

*Table 2-7 Cisco ASR1000-SIP40 Physical Specifications*

Description	Specifications
Physical dimension (HxWxD)	1.630 inches (41.4 mm) x 16.725 inches (424.8 mm) x 14.187 inches (360.3 mm)
Shipping weight	8.5 lb (3.9 kg)
Operating temperature	Nominal—40.9 to 104°F (5 to 40°C) Short Term—40.9 to 131°F (5 to 55°C)
Relative humidity	Operating Humidity Nominal—5% to 85% noncondensing Operating Humidity Short Term—5% to 90% noncondensing
Storage temperature	–40F to 158F (–40°C to 70°C)

## Cisco ASR 1013 Router and Slot Numbering for SIP

The Cisco ASR 1013 Router supports the Cisco ASR1000-SIP40 and Cisco ASR1000-SIP10. In the Cisco ASR 1013 Router, the Cisco ASR 1000 Series SIP supports:

- Four half-height SPAs with up to 24 ports per SPA
- Two full-height SPAs with up to 48 ports per SPA
- Two half-height and one full-height SPA combination that does not exceed 96 ports

The Cisco ASR 1013 Router uses the same SPA subslot numbering as the Cisco ASR 1006 Router and Cisco ASR 1004 Router.

*Figure 2-5 Cisco ASR 1013 Router SPA Interface Slot Numbering*

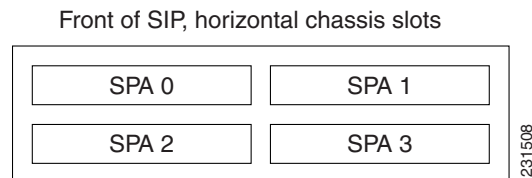

Figure 2-6 shows the slot numbering for the shared port adapters on the Cisco ASR 1013 Routers.



Note

The Cisco ASR1000-ESP10 and Cisco ASR1000-ESP20 will not plug into the Cisco ASR 1013 Router ESP slots. The Cisco ASR 1013 Router supports six SIP slots only with the combination of Cisco ASR1000-ESP40 and RP2.

Figure 2-6 Cisco ASR 1013 Router SPA Interface Slot Numbering

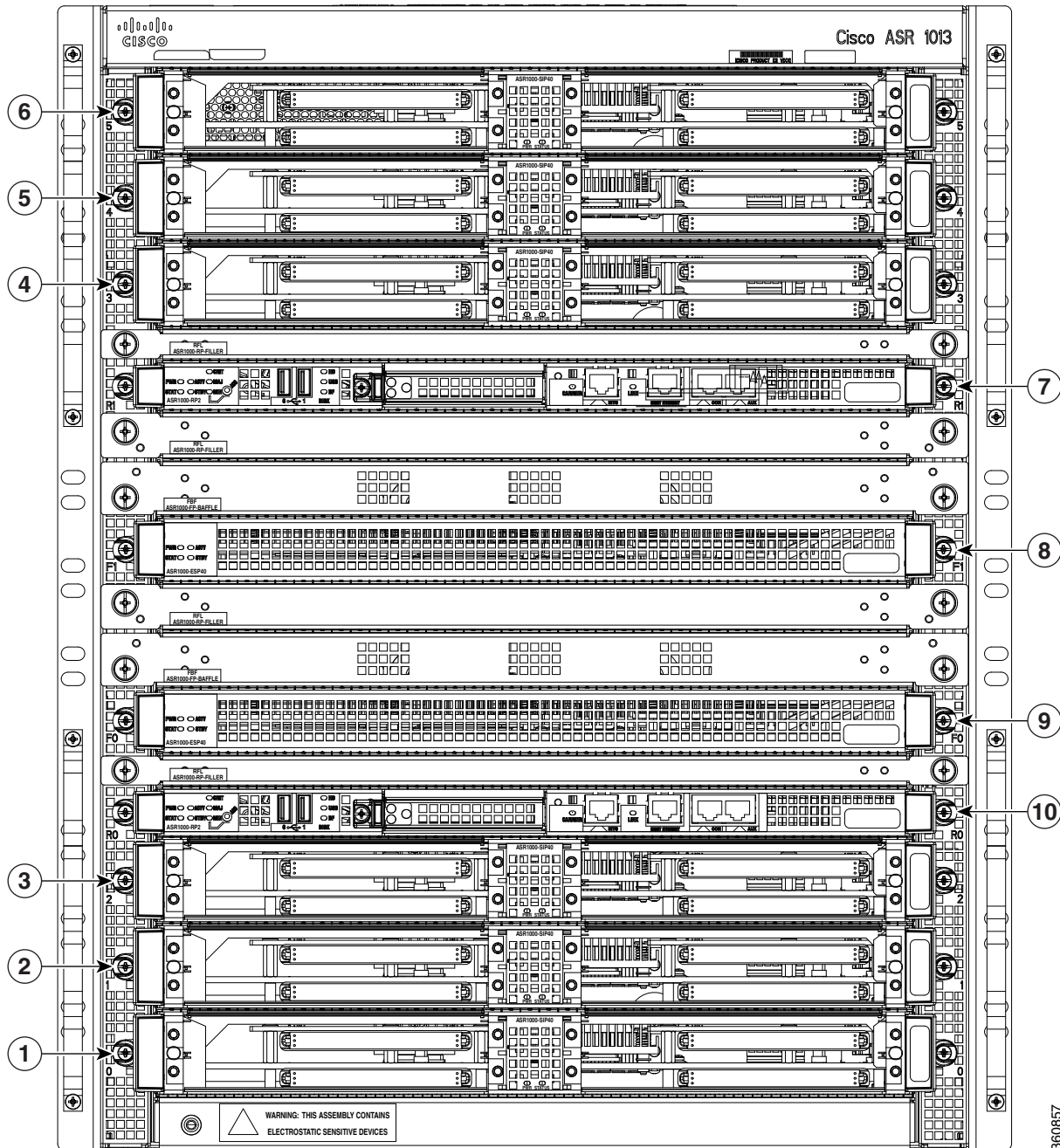

<b>1</b>	SPA—Slot 0	<b>6</b>	SPA—Slot 5
<b>2</b>	SPA—Slot 1	<b>7</b>	RP-2—R1
<b>3</b>	SPA—Slot 2	<b>8</b>	ESP-40/ESP-100—F1
<b>4</b>	SPA—Slot 3	<b>9</b>	RP-Filler—F0
<b>5</b>	SPA—Slot 4	<b>10</b>	RP-2—R0





# Overview: Cisco ASR 1000 Series Aggregation Services Routers SPAs

This chapter describes the shared port adapters (SPAs) that are supported on the Cisco ASR 1000 Series Aggregation Services Routers and contains the following sections:

- [SPA Summary, page 3-2](#)
- [Bandwidth Oversubscription, page 3-5](#)

## ATM SPAs

- [1-Port and 3-Port Clear Channel OC-3 ATM SPA Overview, page 3-8](#)
- [1-Port Clear Channel OC-12 ATM SPA Overview, page 3-10](#)

## Ethernet SPAs

- [4-Port and 8-Port Fast Ethernet SPA Overview, page 3-13](#)
- [1-Port 10-Gigabit Ethernet SPA Overview, page 3-15](#)
- [2-Port Gigabit Ethernet SPA Overview, page 3-19](#)
- [5-Port Gigabit Ethernet SPA Overview, page 3-21](#)
- [8-Port Gigabit Ethernet SPA Overview, page 3-23](#)
- [10-Port Gigabit Ethernet SPA Overview, page 3-25](#)
- [2-Port Gigabit Synchronous Ethernet SPA Overview, page 3-33](#)

## Packet Over SONET SPAs

- [2-Port Gigabit Synchronous Ethernet SPA Overview, page 3-33](#)
- [1-Port OC-48c/STM-16 POS SPA Overview, page 3-41](#)
- [2-Port and 4-Port OC-48c/STM-16 POS SPA Overview, page 3-43](#)
- [1-Port OC-12c/STM-4 POS SPA Overview, page 3-46](#)
- [2-Port, 4-Port, and 8-Port OC-12c/STM-4 POS SPA Overview, page 3-51](#)
- [1-Port OC-192c/STM-64 POS/RPR XFP SPA Overview, page 3-54](#)

## Serial SPAs

- [4-Port and 8-Port Fast Ethernet SPA Overview, page 3-13](#)
- [2-Port, 4-Port, and 8-Port Clear-Channel T3/E3 Serial SPA Overview, page 3-58](#)

- [2-Port and 4-Port Channelized T3 Serial SPA Overview, page 3-60](#)
- [4-Port Serial Interface SPA Overview, page 3-63](#)
- [8-Port Channelized T1/E1 SPA Overview, page 3-67](#)
- [1-Port Channelized STM-1/OC-3 SPA Overview, page 3-69](#)
- [1-Port Channelized OC-12/STM-4 SPA Overview, page 3-72](#)

#### Service SPAs

- [Cisco WebEx Node for ASR 1000 Series Overview, page 3-75](#)
- [Cisco DSP SPA for ASR 1000 Series Overview, page 3-76](#)

#### Circuit Emulation SPAs

- [1-Port Channelized OC3 STM-1 ATM CEoP SPA Overview, page 3-79](#)
- [2-Port Channelized T3/E3 ATM CEoP SPA Overview, page 3-81](#)
- [24-Port Channelized T1/E1/J1 ATM CEoP SPA Overview, page 3-83](#)

## SPA Summary

Summary descriptions of the SPAs that are supported on the Cisco ASR 1000 Series Routers are provided in [Table 3-1](#).

**Table 3-1 SPA Summary**

SPA	Product Number	Number of Ports	Minimum IOS XE Release	Minimum Hardware Revision
<b>ATM SPAs</b>				
1-Port Clear Channel OC-3 ATM SPA	SPA-1XOC3-ATM-V2	1	Cisco IOS XE 2.3	1.0
3-Port Clear Channel OC-3 ATM SPA	SPA-3XOC3-ATM-V2	3	Cisco IOS XE 2.3	1.0
1-Port Clear Channel OC-12 ATM SPA	SPA-1XOC12-ATM-V2	1	Cisco IOS XE 2.5	1.0
<b>Ethernet SPAs</b>				
4-Port Fast Ethernet SPA	SPA-4X1FE-TX-V2	4	Cisco IOS XE 2.1	1.0
8-Port Fast Ethernet SPA	SPA-8X1FE-TX-V2	8	Cisco IOS XE 2.1	1.0
1-Port 10-Gigabit Ethernet SPA	SPA-1X10GE-L-V2	1	Cisco IOS XE 2.1	1.0
1-Port 10-Gigabit Ethernet LAN/WAN-PHY SPA	SPA-1X10GE-WL-V2	1	Cisco IOS XE 3.3.0S	1.0
2-Port Copper and Optical Gigabit Ethernet SPA	SPA-2X1GE-V2	2	Cisco IOS XE 2.1	1.0

Table 3-1 SPA Summary (continued)

SPA	Product Number	Number of Ports	Minimum IOS XE Release	Minimum Hardware Revision
5-Port Gigabit Ethernet SPA	SPA-5X1GE-V2	5	Cisco IOS XE 2.1	1.0
8-Port Gigabit Ethernet SPA	SPA-8X1GE-V2	8	Cisco IOS XE 2.1	1.0
10-Port Gigabit Ethernet SPA	SPA-10X1GE-V2	10	Cisco IOS XE 2.1	1.0
2-Port Gigabit Synchronous Ethernet SPA	SPA-2X1GE-SYNCE	2	Cisco IOS XE 3.2S	1.0
<b>Packet Over SONET SPAs</b>				
2-Port OC-3c/STM-1 POS SPA	SPA-2XOC3-POS	2	Cisco IOS XE 2.1	1.0
2-Port OC-3c/STM-1 POS SPA (license)	SPA-2XOC3-POS-V2	4 (ships SPA-4XOC3-POS-V2)	Cisco IOS XE 3.4	1.0
1-Port OC-12c/STM-4 Multirate POS SPA (license)	SPA-1XOC12-POS-V2	2 (ships SPA-2XOC12-POS)	Cisco IOS XE 2.4	1.0
4-Port OC-3c/STM-1 POS SPA	SPA-4XOC3-POS	4	Cisco IOS XE 2.1	1.0
4-Port OC-3c/STM-1 POS SPA, Version 2	SPA-4XOC3-POS-V2	4	Cisco IOS XE 3.4	1.0
8-Port OC-3c/STM-1 POS SPA	SPA-8XOC3-POS	8	Cisco IOS XE 2.4	1.0
2-Port OC-12c/STM-4 Multirate POS SPA	SPA-2XOC12-POS	2	Cisco IOS XE 2.4	1.0
4-Port OC-12c/STM-4 Multirate POS SPA	SPA-4XOC12-POS	4	Cisco IOS XE 2.4	1.0
8-Port OC-12c/STM-4 Multirate POS SPA	SPA-8XOC12-POS	8	Cisco IOS XE 2.4	1.0
1-Port OC-48c/STM-16 POS SPA	SPA-1XOC48-POS	1	Cisco IOS XE 2.4	1.0
2-Port OC-48c/STM-16 POS SPA	SPA-2XOC48-POS	2	Cisco IOS XE 2.2	1.0
4-Port OC-48c/STM-16 POS SPA	SPA-4XOC48-POS	4	Cisco IOS XE 2.2	1.0
1-Port OC-192c/STM-64 POS/RPR XFP SPA	SPA-1XOC192-POS	1	Cisco IOS XE 2.4	1.0
<b>Serial SPAs</b>				

Table 3-1 SPA Summary (continued)

SPA	Product Number	Number of Ports	Minimum IOS XE Release	Minimum Hardware Revision
1-Port Channelized OC-3/STM-1 SPA	SPA-1XCHSTM1/OC3	1	Cisco IOS XE 2.2	1.0
1-Port Channelized OC-3/STM-1 SPA, Version 2	SPA-1CHSTM1/OC3V2	1	Cisco IOS XE 3.10.3/3.11.2/3.12	1.0
1-Port Channelized OC-12/STM-4 SPA	SPA-1XCHOC12/DS0	1	Cisco IOS XE 2.6	1.0
8-Port Channelized T1/E1 SPA	SPA-8XCHT1/E1	8	Cisco IOS XE 2.1	1.0
8-Port Channelized T1/E1 SPA, Version 2	SPA-8XCHT1/E1-V2	8	Cisco IOS XE 3.10.1	1.0
2-Port Channelized T3 SPA	SPA-2XCT3/DS0	2	Cisco IOS XE 2.1	1.0
2-Port Channelized T3 SPA, Version 2	SPA-2XCT3/DS0-V2	2	Cisco IOS XE 3.10.3/3.11.2/3.12	1.0
4-Port Channelized T3 SPA	SPA-4XCT3/DS0	4	Cisco IOS XE 2.1	1.0
4-Port Channelized T3 SPA, Version 2	SPA-4XCT3/DS0-V2	4	Cisco IOS XE 3.10.3/3.11.2/3.12	1.0
2-Port Clear-Channel T3/E3 SPA	SPA-2XT3/E3	2	Cisco IOS XE 2.1	1.0
2-Port Clear-Channel T3/E3 SPA, Version 2	SPA-2XT3/E3-V2	2	Cisco IOS XE 3.10.3/3.11.2/3.12	1.0
4-Port Clear-Channel T3/E3 SPA	SPA-4XT3/E3	4	Cisco IOS XE 2.1	1.0
4-Port Clear-Channel T3/E3 SPA, Version 2	SPA-4XT3/E3-V2	4	Cisco IOS XE 3.10.3/3.11.2/3.12	1.0
8-Port Clear-Channel T3/E3 SPA	SPA-8XT3/E3	8	Cisco IOS XE 3.8	1.0
4-Port Serial SPA	SPA-4XT-Serial	4	Cisco IOS XE 2.1	1.0
<b>Service SPAs</b>				
Cisco WebEx Node for ASR 1000 Series	SPA-WMA-K9	N/A	Cisco IOS XE 2.4	1.0
Cisco DSP SPA for ASR 1000 Series	SPA-DSP	N/A	Cisco IOS XE 3.2S	1.0
<b>CEOP (Circuit Emulation Over Packet) SPA</b>				



**Table 3-1 SPA Summary (continued)**

SPA	Product Number	Number of Ports	Minimum IOS XE Release	Minimum Hardware Revision
1-Port Channelized OC3/STM-1 ATM and Circuit Emulation SPA	SPA-1CHOC3-CE-ATM	1	Cisco IOS XE 3.3.0S	1.0
2-Port Channelized T3/E3 ATM CEoP SPA	SPA-2CHT3-CE-ATM	2	Cisco IOS XE 3.4.0S	1.0
24-Port Channelized T1/E1 ATM CEoP SPA	SPA-24CHT1-CE-ATM	24	Cisco IOS XE 3.4.0S	1.0

## Checking Hardware and Software Compatibility

To check the minimum software requirements of Cisco IOS software with the hardware installed on your router, Cisco maintains the Software Advisor tool on Cisco.com. This tool does not verify whether SIPs or SPAs within a system are compatible, but it does provide the minimum Cisco IOS requirements for individual hardware modules or components.



### Note

Access to this tool is limited to users with Cisco.com login accounts.

To access Software Advisor, click **Login** at Cisco.com, type “Software Advisor” in the SEARCH box, and click **GO**. Click the link for the Software Advisor tool.

Choose a product family or enter a specific product number to search for the minimum supported software release needed for your hardware.

## Bandwidth Oversubscription

Oversubscribing the bandwidth limit recommendations of a router can result in decreased or degraded performance. For this reason, it is important to determine the amount of bandwidth used by the SPAs on the router and verify that the total bandwidth used by all SPAs does not exceed the recommended bandwidth limit of the router.

Table 3-2 provides information about the bandwidth for each port (per-port bandwidth) on a SPA and the cumulative bandwidth (total bandwidth) for all ports available on the SPA.

**Table 3-2 SPA Bandwidth Capacity**

SPA	Per-Port Bandwidth	Number of Ports	Total Bandwidth
<b>ATM SPAs</b>			
1-Port Clear Channel OC-3 ATM SPA	155.52 Mbps	1	155.52 Mbps
3-Port Clear Channel OC-3 ATM SPA	155.52 Mbps	3	466.56 Mbps
1-Port Clear Channel OC-12 ATM SPA	622.08 Mbps	1	622.08 Mbps
<b>Ethernet SPAs</b>			
4-Port Fast Ethernet SPA	100 Mbps	4	400 Mbps

Table 3-2 SPA Bandwidth Capacity (continued)

SPA	Per-Port Bandwidth	Number of Ports	Total Bandwidth
8-Port Fast Ethernet SPA	100 Mbps	8	800 Mbps
1-Port 10-Gigabit Ethernet SPA	10 Gbps	1	10 Gbps
1-Port 10-Gigabit Ethernet LAN/WAN-PHY SPA	LAN Mode: 10 Gbps WAN Mode: 9.2946 Gbps	1	LAN Mode: 10 Gbps WAN Mode: 9.2946 Gbps
2-Port Copper and Optical Gigabit Ethernet SPA	1 Gbps	2	2 Gbps
5-Port Gigabit Ethernet SPA	1 Gbps	5	5 Gbps
8-Port Gigabit Ethernet SPA	1 Gbps	8	8 Gbps
10-Port Gigabit Ethernet SPA	1 Gbps	10	10 Gbps
2-Port Synchronous Gigabit Ethernet SPA	1 Gbps	2	2 Gbps
<b>Packet Over SONET SPAs</b>			
2-Port OC-3c/STM-1 POS SPA	155.52 Mbps	2	311.04 Mbps
4-Port OC-3c/STM-1 POS SPA	155.52 Mbps	4	622.08 Mbps
8-Port OC-3c/STM-1 POS SPA	155.52 Mbps	8	1244.16 Mbps
2-Port OC-12c/STM-4 Multirate POS SPA	155.52 Mbps or 622.08 Mbps	2	1244.16 Mbps <sup>1</sup>
4-Port OC-12c/STM-4 Multirate POS SPA	155.52 Mbps or 622.08 Mbps	4	2488.32 Mbps <sup>2</sup>
8-Port OC-12c/STM-4 Multirate POS SPA	155.52 Mbps or 622.08 Mbps	8	4976.64 Mbps <sup>3</sup>
1-Port OC-48c/STM-16 POS SPA	2.488 Gbps	1	2.488 Gbps
2-Port OC-48c/STM-16 POS SPA	2.488 Gbps	2	4976 Mbps
4-Port OC-48c/STM-16 POS SPA	2.488 Gbps	4	9.952 Mbps
1-Port OC-192c/STM-64 POS/RPR XFP SPA	10 Gbps	1	10 Gbps
<b>Serial SPAs</b>			
1-Port Channelized OC-3/STM-1 SPA	155.52 Mbps	1	155.52 Mbps
1-Port Channelized OC-12/STM-4 SPA	622.08 Mbps	1	622.08 Mbps
8-Port Channelized T1/E1 SPA	1.544 Mbps (T1) 2.048 Mbps (E1)	8	12.35 Mbps (T1) 16.38 Mbps (E1)
2-Port Channelized T3 SPA	44.736 Mbps	2	89.47 Mbps
4-Port Channelized T3 SPA	44.736 Mbps	4	178.94 Mbps
2-Port Clear-Channel T3/E3 SPA	44.736 Mbps (T3) 34.368 Mbps (E3)	2	89.47 Mbps (T3) 68.74 Mbps (E3)
4-Port Clear-Channel T3/E3 SPA	44.736 Mbps (T3) 34.368 Mbps (E3)	4	178.94 Mbps (T3) 137.47 Mbps (E3)
8-Port Clear-Channel T3/E3 SPA	44.736 Mbps (T3) 34.368 Mbps (E3)	8	357.88 Mbps (T3) 274.88 Mbps (E3)

**Table 3-2 SPA Bandwidth Capacity (continued)**

SPA	Per-Port Bandwidth	Number of Ports	Total Bandwidth
4-Port Serial SPA	128 Kbps (EIA/TIA-232) 8064 Kbps (V.35, EIA/TIA-449, -530, and -530a) 2 Mbps (X.21)	4	8 Mbps <sup>4</sup>
<b>CEoP (Circuit Emulation over Packet) SPA</b>			
1-Port Channelized OC-3 ATM CEoP SPA	155 Mbps	1	155 Mbps
2-Port Channelized T3/E3 ATM CEoP SPA	44.736 Mbps (T3)	2	89.47 Mbps (T3)
24-Port Channelized T1/E1 ATM CEoP SPA	1.544 Mbps (T1)	24	37.06 Mbps (T1)
	2.048 Mbps (E1)		49.15 Mbps (E1)

1. Total bandwidth value assumes two OC-12c/STM-4 optics modules.
2. Total bandwidth value assumes four OC-12c/STM-4 optics modules.
3. Total bandwidth value assumes eight OC-12c/STM-4 optics modules.
4. Total bandwidth value assumes four ports of maximum bandwidth.

## Cisco ASR1000-SIP10 Oversubscription Guidelines

The total available bandwidth in your router ultimately depends on the features that you have enabled, and the combination of hardware installed. This section describes some of the basic guidelines that you can use to plan for a possible oversubscription on the Cisco ASR1000-SIP10.

Each Cisco ASR1000-SIP10 supports 4 single-height SPAs. The chassis models of the Cisco ASR 1000 Series Aggregation Services Routers support a different maximum number of SIPs as follows:

- Cisco ASR 1002 Router, Cisco ASR1002-Fixed Router, and Cisco ASR1002-X Router—1 integrated SIP
- Cisco ASR 1004 Router — 2 SIPs
- Cisco ASR 1006 Router — 3 SIPs

Each Cisco ASR1000-SIP10 has a 10 Gbps link to the Embedded Services Processor (ESP). Therefore, there is an aggregate bandwidth limit—the sum of the total SPA bandwidth installed in the SIP—of 10 Gbps per SIP. This limit can be exceeded with the installation of some combinations of SPAs. See [Table 3-1](#) for individual SPA bandwidth values. This aggregate bandwidth is then subject to the maximum bandwidth limitations of the ESP (5, 10, or 20 Gbps) depending on the ESP model installed.

## Cisco ASR1000-SIP40 Oversubscription Guidelines

The total available bandwidth in your router ultimately depends on the features that you have enabled, and the combination of hardware installed. However, this section describes some of the basic guidelines that you can use to plan for a possible oversubscription on the Cisco ASR1000-SIP40.

Each Cisco ASR1000-SIP40 supports:

- Four half-height (¼ rate or full rate or combination) SPAs with upto 24 ports per SPA
- Two full-height (¼ rate or full rate or combination) SPAs with upto 48 ports per SPA

- Combination of two half-height and one full-height SPAs that do not exceed 96 ports

**Warning**

**Double-wide SPAs are not supported on Cisco ASR1000-SIP40.**

The chassis models of the Cisco ASR 1000 Series Aggregation Services routers support a different maximum number of Cisco ASR1000-SIP40 as follows:

- Cisco ASR 1006 Router — three SIPs
- Cisco ASR 1013 Router — six SIPs

**Note**

The Cisco ASR1000-SIP40 is not supported on the Cisco ASR1002 Router, Cisco ASR 1002-Fixed Router, and Cisco ASR 1002-X Router.

## 1-Port and 3-Port Clear Channel OC-3 ATM SPA Overview

The 1-Port and 3-Port Clear Channel OC-3 ATM SPA is a single-height SPA that installs into one SIP subslot. The 1-Port and 3-Port Clear Channel OC-3 ATM SPA with small form-factor pluggable (SFP) optical transceiver modules provides SONET and SDH network connectivity with a per-port bandwidth of 155.52 Mbps.

The following sections describe the 1-Port and 3-Port Clear Channel OC-3 ATM SPA:

- [1-Port and 3-Port Clear Channel OC-3 ATM SPA LEDs, page 3-8](#)
- [1-Port and 3-Port Clear Channel OC-3 ATM SPA Interface Specifications, page 3-9](#)
- [1-Port and 3-Port Clear-Channel OC-3 ATM SPA Cables and Connectors, page 3-9](#)

## 1-Port and 3-Port Clear Channel OC-3 ATM SPA LEDs

The 1-Port and 3-Port Clear Channel OC-3 ATM SPA has three types of LEDs: two LEDs for each port on the SPA and one STATUS LED, as shown in [Figure 3-1](#).

**Figure 3-1** 3-Port Clear-Channel OC-3 ATM SPA Faceplate

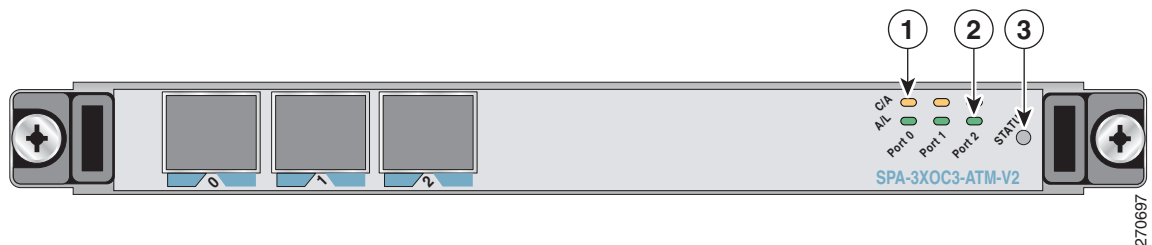

1	C/A (Carrier/Alarm) LED	3	STATUS LED
2	A/L (Active/Loopback) LED		

Table 3-3 describes the 1-Port and 3-Port Clear Channel OC-3 ATM SPA LEDs.

**Table 3-3 1-Port and 3-Port Clear Channel OC-3 ATM SPA LEDs**

LED Label	Color	State	Meaning
C/A	Off	Off	Port is not enabled by software.
	Green	On	Port is enabled by software, and there is a valid SONET signal without any alarms.
	Amber	On	Port is enabled by software, and there is at least one alarm.
A/L	Off	Off	Port is not enabled by software.
	Green	On	Port is enabled by software, and loopback is off.
	Amber	On	Port is enabled by software, and loopback is on.
STATUS	Off	Off	SPA power is off.
	Green	On	SPA is ready and operational.
	Amber	On	SPA power is on and good and the SPA is being configured.

## 1-Port and 3-Port Clear Channel OC-3 ATM SPA Interface Specifications

The physical layer interface for the 1-Port and 3-Port Clear Channel OC-3 ATM SPA is Optical Carrier-3 (OC-3), and the data link layer is designed to comply with ATM specifications. The 1-Port and 3-Port Clear Channel OC-3 ATM SPA provides up to four 155-Mbps OC-3 network interfaces for all supported platforms.

## 1-Port and 3-Port Clear-Channel OC-3 ATM SPA Cables and Connectors

The 1-Port and 3-Port Clear Channel OC-3 ATM SPA uses a small form-factor pluggable (SFP) optical transceiver module installed in each port for SONET and SDH single-mode and multimode optical fiber connection (see [Figure 3-2](#)).

Each SPA port accepts an SFP module with a duplex LC-type receptacle that allows connection to single-mode or multimode optical fiber.

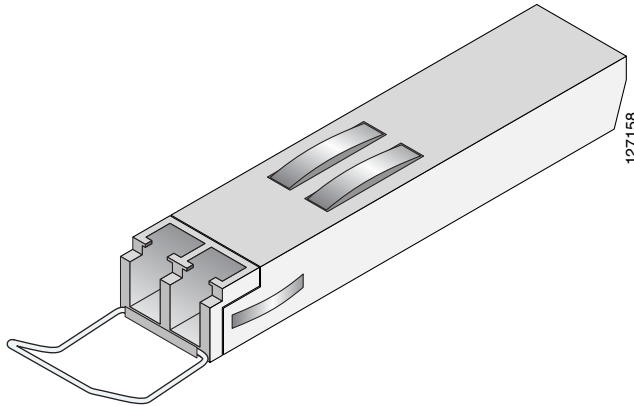
**Figure 3-2 SFP Optics Module**

The SFP optical transceiver modules used with the 1-Port and 3-Port Clear Channel OC-3 ATM SPA provide the following optical fiber options:

- Multimode—155-Mbps, OC-3 optical fiber (SONET STS-3c or SDH STM-1)  
Use a multimode optical fiber that has a core/cladding diameter of 62.5/125 microns.
- Single-mode—155-Mbps, OC-3 optical fiber (SONET STS-3c or SDH STM-1)  
Use a single-mode optical fiber that has a modal-field diameter of  $8.7 \pm 0.5$  microns. (Nominal diameter is approximately 10/125 microns.)

For single-mode and multimode optical fiber connections, you can use either a duplex LC-type cable (see [Figure 3-3](#)) or two simplex LC-type cables, one for transmit (TX) and one for receive (RX).

Use a single-mode (for intermediate-reach or long-reach configurations) or multimode optical fiber cable to connect your router to a network or to connect two 1-Port and 3-Port Clear Channel OC-3 ATM SPA-equipped routers back-to-back.

Long-range SFP optical transceiver modules (for long-reach configurations) cannot be connected back-to-back without using an attenuator between them.

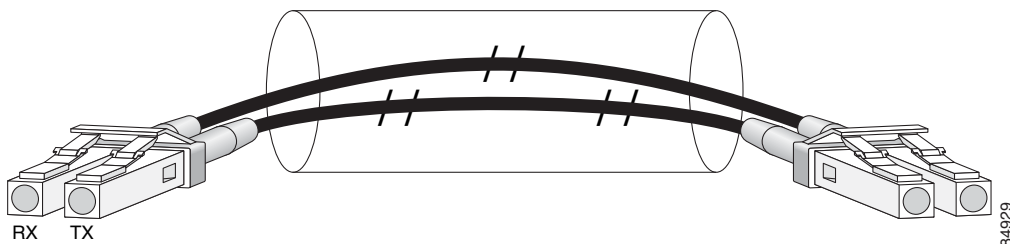
**Figure 3-3 Duplex Patch Cable with LC-Type Cables**

## 1-Port Clear Channel OC-12 ATM SPA Overview

The 1-Port Clear Channel OC-12 ATM SPA is a single-height ATM SPA that can be installed into one SIP subslot. The OC-12 ATM SPA with small form-factor pluggable (SFP) optical transceiver modules provides SONET and SDH network connectivity with a per-port bandwidth of 622.08 Mbps. For more information about SPA bandwidth, see the “Bandwidth Oversubscription” section in this chapter.

The following sections describe the 1-Port Clear Channel OC-12 ATM SPA:

- [1-Port Clear Channel OC-12 ATM SPA LEDs, page 3-11](#)
- [1-Port Clear Channel OC-12 ATM SPA Interface Specifications, page 3-12](#)
- [1-Port Clear Channel OC-12 ATM SPA Cables and Connectors, page 3-12](#)

## 1-Port Clear Channel OC-12 ATM SPA LEDs

The 1-Port Clear Channel OC-12 ATM SPA has three types of LEDs. There are two LEDs for the port on the SPA, and one STATUS LED, as shown in [Figure 3-4](#).

**Figure 3-4** 1-Port Clear Channel OC-12 ATM SPA Faceplate



<b>1</b>	C/A (Carrier/Alarm) LED	<b>3</b>	STATUS LED
<b>2</b>	A/L (Active Loopback) LED		

The 1-Port Clear Channel OC-12 ATM SPA LEDs are described in [Table 3-4](#).

**Table 3-4** 1-Port Clear Channel OC-12 ATM SPA LEDs

LED Label	Color	State	Meaning
C/A	Off	Off	Port is not enabled by software.
	Green	On	Port is enabled by software, and there is a valid SONET signal without any alarms.
	Amber	On	Port is enabled by software, and there is at least one alarm.
A/L	Off	Off	Port is not enabled by software.
	Green	On	Port is enabled by software, and loopback is off.
	Amber	On	Port is enabled by software, and loopback is on.
STATUS	Off	Off	SPA power is off.
	Amber	On	SPA power is on and good, and SPA is being configured.
	Green	On	SPA is ready and operational.

## 1-Port Clear Channel OC-12 ATM SPA Interface Specifications

The physical layer interface for the 1-Port Clear Channel OC-12 ATM SPA is Optical Carrier-12 (OC-12), and the 1-Port Clear Channel OC-12 ATM SPA is designed to comply with ATM specifications. The 1-Port Clear Channel OC-12 ATM SPA provides one 622.08 Mbps OC-12 network interface for all supported platforms.

The single SPA port accepts an SFP module with a duplex LC-type receptacle that allows connection to single-mode or multimode optical fiber.

## 1-Port Clear Channel OC-12 ATM SPA Cables and Connectors

The 1-Port Clear Channel OC-12 ATM SPA uses a small form-factor pluggable (SFP) optical transceiver module installed in each port for SONET and SDH single-mode and multimode optical fiber connection (see [Figure 3-5](#)).

The 1-Port Clear Channel OC-12 ATM SPA supports the following types of optical transceiver modules:

Multimode (MM) SFP module—SFP-OC12-MM

Short-reach (SR) SFP module—SFP-OC12-SR

Intermediate-reach (IR) SFP module (15 km)—SFP-OC12-IR1

Long-reach (LR) SFP module (40 km)—SFP-OC12-LR1

Long-reach (LR) SFP module (80 km)—SFP-OC12-LR2

The SR, IR, and LR1 transceivers provide a full-duplex 622.08-Mbps, laser-based SONET/SDH-compliant interface with an average wavelength of 1310 nm. The LR2 transceivers provide a full-duplex, 622.08-Mbps, laser-based SONET/SDH-compliant interface with an average wavelength of 1530 nm. The multimode transceiver provides a full-duplex, 622.08-Mbps, LED-based SONET/SDH-compliant interface with an average wavelength of 1325 nm.

**Figure 3-5** SFP Optics Module

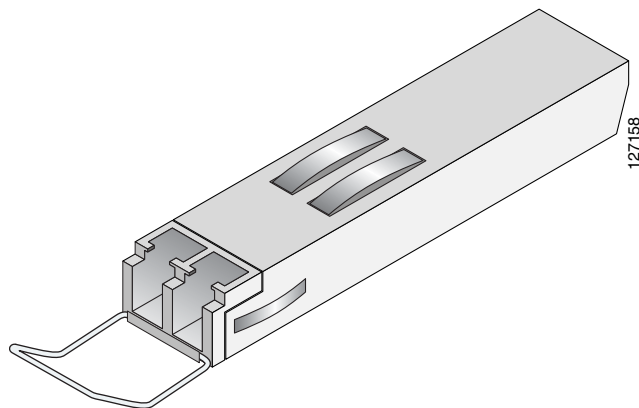

The 1-Port Clear Channel OC-12 ATM SPA provides the following optical fiber options:

- Multimode—622.08-Mbps, OC-12 optical fiber (SONET STS-12c or SDH STM-4)  
Use a multimode optical fiber that has a core/cladding diameter of 62.5/125 microns.
- Single-mode—622.08-Mbps, OC-12 optical fiber (SONET STS-12c or SDH STM-4)



Use a single-mode optical fiber that has a modal-field diameter of  $8.7 \pm 0.5$  microns. (Nominal diameter is approximately 10/125 microns.)

For single-mode and multimode optical fiber connections, you can use either a duplex LC-type cable (see [Figure 3-6](#)) or two simplex LC-type cables, one for transmit (TX) and one for receive (RX).

**Figure 3-6 Duplex Patch Cable with LC-Type Connectors**

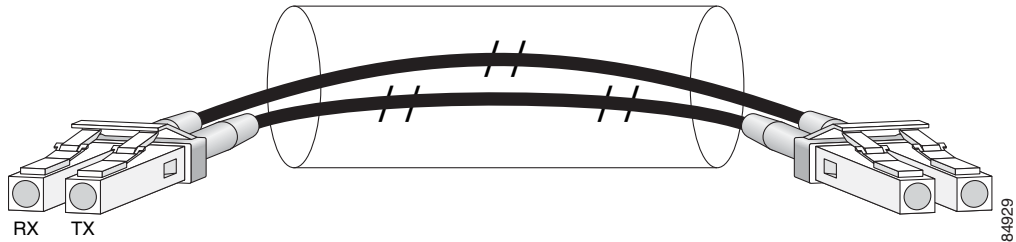

## 4-Port and 8-Port Fast Ethernet SPA Overview

The following sections describe the 4-Port and 8-Port Fast Ethernet SPA:

- [4-Port and 8-Port Fast Ethernet SPA LEDs](#), page 3-13
- [4-Port and 8-Port Fast Ethernet SPA Cables, Connectors, and Pinouts](#), page 3-14

## 4-Port and 8-Port Fast Ethernet SPA LEDs

The 4-Port and 8-Port Fast Ethernet SPA has two types of LEDs: an A/L LED for each port on the SPA, and one STATUS LED, as shown in [Figure 3-7](#).

**Figure 3-7 8-Port Fast Ethernet SPA Faceplate**

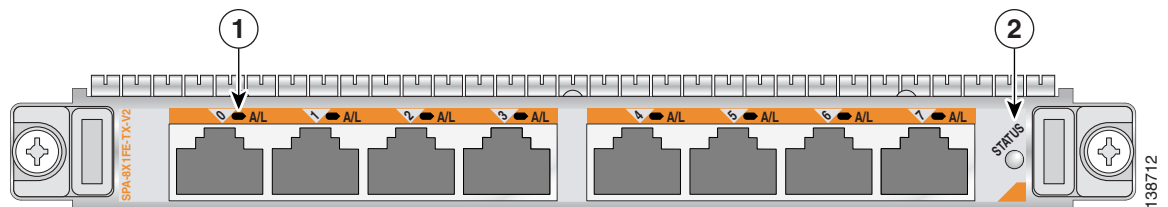

<b>1</b>	A/L (Active/Link) LED	<b>2</b>	STATUS LED
----------	-----------------------	----------	------------

Table 3-5 describes the 4-Port and 8-Port Fast Ethernet SPA LEDs.

**Table 3-5 4-Port and 8-Port Fast Ethernet SPA LEDs**

LED Label	Color	State	Meaning
Port Number A/L (0, 1, 2, 3, 4, 5, 6 or 7) <sup>1</sup>	Off	Off	Port is not enabled.
	Green	On	Port is enabled and the link is up.
	Amber	On	Port is enabled and the link is down.
STATUS	Off	Off	SPA power is off.
	Green	On	SPA is ready and operational.
	Amber	On	SPA power is on and good, and the SPA is being configured.

1. In this case, port number refers to the numbered LEDs on the 8-Port Fast Ethernet SPA (0, 1, 2, 3, 4, 5, 6, or 7). Each LED number on the 8-Port Fast Ethernet SPA references a port on the SPA.

## 4-Port and 8-Port Fast Ethernet SPA Cables, Connectors, and Pinouts

The interface connectors on the 4-Port and 8-Port Fast Ethernet SPA are four or eight individual RJ-45 receptacles. You can use all interface connectors simultaneously. Each connection supports IEEE 802.3 and Ethernet 10/100BASE-T interfaces compliant with appropriate standards. Cisco does not supply Category 5 unshielded twisted pair (UTP) RJ-45 cables; these cables are available commercially.

Figure 3-8 shows the RJ-45 connector. Table 3-6 lists the pinouts and signals for the RJ-45 connector.

**Figure 3-8 RJ-45 Connector Pinouts, Plug, and Receptacle**

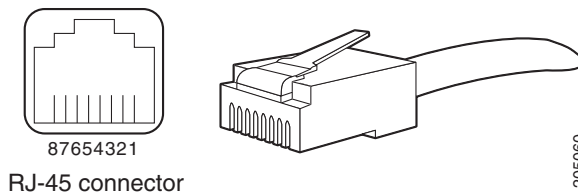

**Table 3-6 RJ-45 Connector Pinouts**

Pin	Description
1	Transmit data + (TxD+)
2	TxD-
3	Receive data + (RxD+)
6	RxD-



**Note**

Referring to the RJ-45 pinout in Table 3-6, proper common-mode line terminations should be used for the unused Category 5 UTP cable pairs 4/5 and 7/8. Common-mode termination reduces the contributions to electromagnetic interference (EMI) and susceptibility to common-mode sources. Wire pairs 4/5 and 7/8 are actively terminated in the RJ-45 port circuitry in the 4-Port and 8-Port Fast Ethernet SPA.

The 4-Port and 8-Port Fast Ethernet SPA supports automatic MDI/MDIX crossover at all speeds of operation allowing the SPA to work with straight-through and crossover Ethernet cables. Depending on your RJ-45 interface cabling requirements, use the pinouts in [Figure 3-9](#) and [Figure 3-10](#).

**Figure 3-9** *Straight-Through Cable Pinout, RJ-45 Connection to a Hub or Repeater*

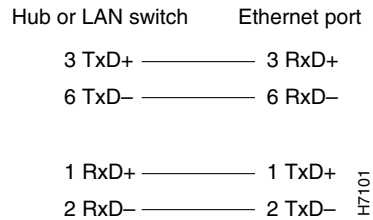

**Figure 3-10** *Crossover Cable Pinout, RJ-45 Connections Between Routers*

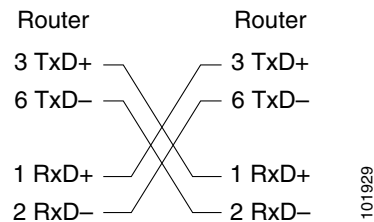

## 1-Port 10-Gigabit Ethernet SPA Overview

There are two types of 1-Port 10-Gigabit Ethernet SPA, the SPA-1X10GE-L-V2, which supports the 10GE LAN-PHY mode of operation at an optical interface bit rate of 10 Gbps, and the SPA-1X10GE-WL-V2, which supports both the 10GE LAN-PHY mode of operation (at 10 Gbps) and the 10GE WAN-PHY mode of operation (at 9.2946 Gbps).

The following sections describe the 1-Port 10-Gigabit Ethernet SPA:

- [1-Port 10-Gigabit Ethernet SPA LEDs, page 3-16](#)
- [1-Port 10-Gigabit Ethernet SPA XFP Optical Transceiver Modules, Connectors, and Cables, page 3-17](#)

## 1-Port 10-Gigabit Ethernet SPA LEDs

The 1-Port 10-Gigabit Ethernet SPA has two LEDs, an ACTIVE/LINK LED for the port, and a STATUS LED, as shown in [Figure 3-11](#).

**Figure 3-11** 1-Port 10-Gigabit Ethernet SPA Faceplate

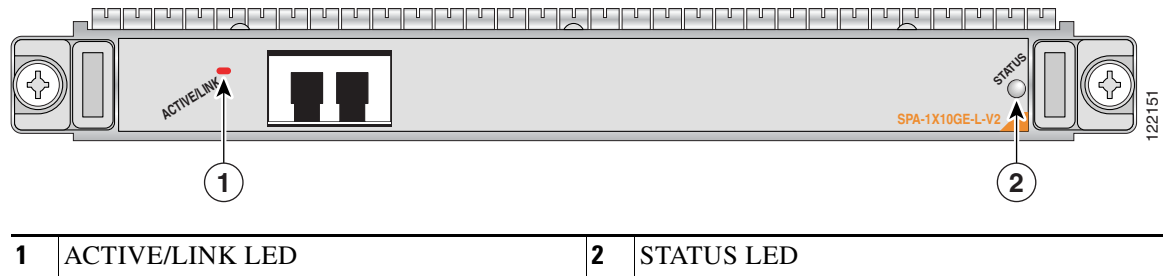

[Figure 3-12](#) displays the 1-Port 10-Gigabit Ethernet LAN/WAN-PHY SPA two LEDs, an ACTIVE/LINK LED for the port, and a STATUS LED.

**Figure 3-12** 1-Port 10-Gigabit Ethernet LAN/WAN-PHY SPA Faceplate

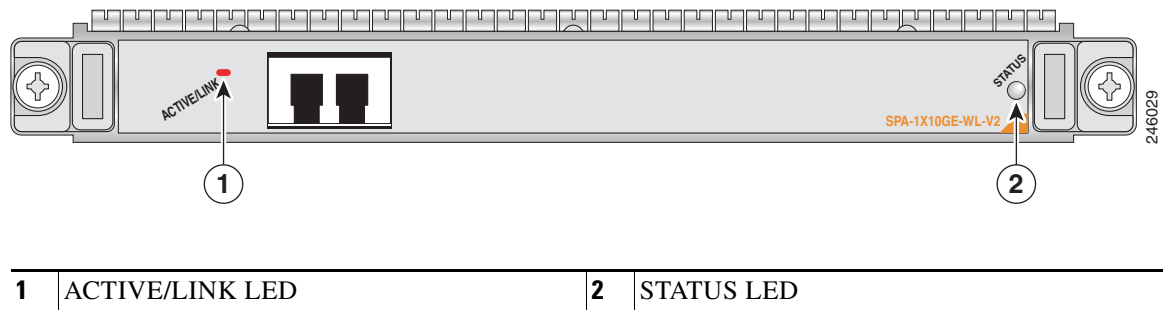

[Table 3-7](#) describes the 1-Port 10-Gigabit Ethernet SPA LEDs.

**Table 3-7** 1-Port 10-Gigabit Ethernet SPA and 1-Port 10-Gigabit Ethernet LAN/WAN-PHY SPA LEDs

LED Label	Color	State	Meaning
ACTIVE/LINK	Off	Off	Port is not enabled by software.
	Green	On	Port is enabled by software and the link is up.
	Amber	On	Port is enabled by software and the link is down.
STATUS	Off	Off	SPA power is off.
	Green	On	SPA is ready and operational.
	Amber	On	SPA power is on and good, and the SPA is being configured.

## 1-Port 10-Gigabit Ethernet SPA XFP Optical Transceiver Modules, Connectors, and Cables

The 1-Port 10-Gigabit Ethernet SPA supports the following types of optical transceiver modules:

- Single-mode short-reach (SR) XFP module—XFP-10GLR-OC192SR
- Single-mode intermediate-reach (IR) XFP module—XFP-10GER-OC192IR
- Single-mode very-long-reach (ZR) XFP module—XFP-10GZR-OC192LR

Cisco qualifies the optics that are approved for use with its SPAs. The above-listed small form-factor pluggable modules (XFPs) are the only optical transceiver modules qualified for use.

Use a single-mode optical fiber that has a modal-field diameter of  $8.7 \pm 0.5$  microns (nominal diameter is approximately 10/125 microns) to connect your router to a network.

Figure 3-13 shows the cable type for use with the XFP optical transceiver module on the 1-Port 10-Gigabit Ethernet SPA.

**Figure 3-13** LC-Type Cables

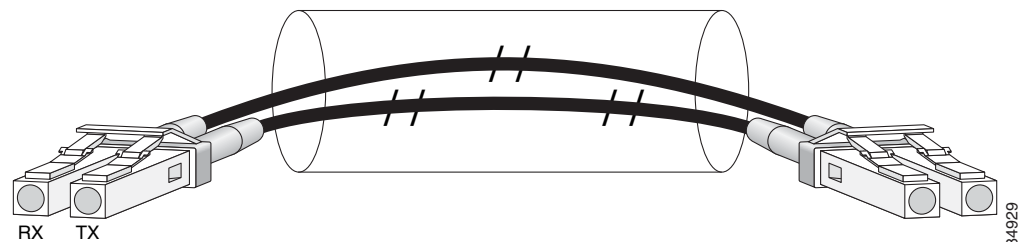

**Note**

The 40-pin connector on the 1-Port 10-Gigabit Ethernet SPA is used for resilient packet ring (RPR) connections

### XFP Connections

The XFP-10GLR-OC192SR, XFP-10GER-OC192IR, and XFP-10GZR-OC192LR modules include an optical transmitter and receiver pair integrated with Clock and Data Recovery (CDR) integrated circuits. The XFP modules provide high-speed serial links at the rate of 10.3125 Gbps (10 Gigabit Ethernet) on single-mode fiber (SMF). The transmit side recovers and retimes the 10-Gbps serial data and passes it to a laser driver. The laser driver biases and modulates a 1310-nm or 1550-nm laser, enabling data transmission over SMF through an LC connector. The receive side recovers and retimes the 10-Gbps optical data stream from a photo detector transimpedance amplifier and passes it to an output driver.

See the label on the XFP module for technology type and model. Figure 3-14 shows an XFP module and Table 3-8 shows the XFP module specifications.

Figure 3-14 XFP Module

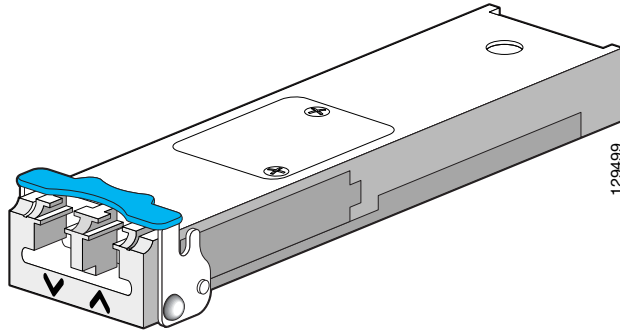

Table 3-8 XFP Module Specifications for the 1-Port 10-Gigabit Ethernet SPA

Specification	Description
Dimensions (H x W x L)	.5 in x .72 in x 2.79 in 12.5 mm x 18.35 mm x 71.1 mm
Wavelength (TX)	10GLR SR-1: 1260 nm to 1355 nm 10GER IR-2: 1530 nm to 1565 nm 10GZR LR-2: 1530 nm to 1565 nm
Cabling distance (maximum)	10GLR SR-1: 6.2 miles (10 km) 10GER IR-2: 24.8 miles (40 km) 10GZR LR-2: 50 miles (80 km)
Operating case temperature range	10GLR SR-1: 23 to 158°F (-5 to 70°C) 10GER IR-2: 23 to 158°F (-5 to 70°C) 10GZR LR-2: 23 to 158°F (-5 to 70°C)
Storage temperature range	10GLR SR-1: -40 to 185°F (-40 to 85°C) 10GER IR-2: -40 to 185°F (-40 to 85°C) 10GZR LR-2: -40 to 185°F (-40 to 85°C)
TX power	10GLR SR-1: -8.2 to 0.5 dBm 10GER IR-2: -4.7 to 4 dBm 10GZR LR-2: 0 to 4 dBm
Receiver sensitivity (maximum)	10GLR SR-1: -12.6 dBm 10GER IR-2: -14.1 dBm 10GZR LR-2: -24 dBm
RX overload	10GLR SR-1: 0.5 dBm 10GER IR-2: -1.0 dBm 10GZR LR-2: -7.0 dBm
Maximum receiver power damage	10GLR SR-1: 5 dBm 10GER IR-2: 5 dBm 10GZR LR-2: 5 dBm

## XFP Port Cabling Specifications

Table 3-9 shows the port cabling specifications for an XFP module.

**Table 3-9** XFP Port Cabling Specifications

XFP Module	Wavelength	Fiber Type
XFP-10GLR-OC192SR	1310 nm	SMF
XFP-10GER-OC192IR	1550 nm	SMF
XFP-10GZR-OC192LR	1550 nm	SMF

## 2-Port Gigabit Ethernet SPA Overview

The following sections describe the 2-Port Copper and Optical Gigabit Ethernet SPA:

- [2-Port Copper and Optical Gigabit Ethernet SPA LEDs](#), page 3-19
- [2-Port Copper and Optical Gigabit Ethernet SPA Cables, Connectors, and Pinouts](#), page 3-20

## 2-Port Copper and Optical Gigabit Ethernet SPA LEDs

The 2-Port Copper and Optical Gigabit Ethernet SPA has two types of LEDs: an A/L LED for each port on the SPA, and one STATUS LED, as shown in [Figure 3-15](#).

**Figure 3-15** 2-Port Copper and Optical Gigabit Ethernet SPA Faceplate

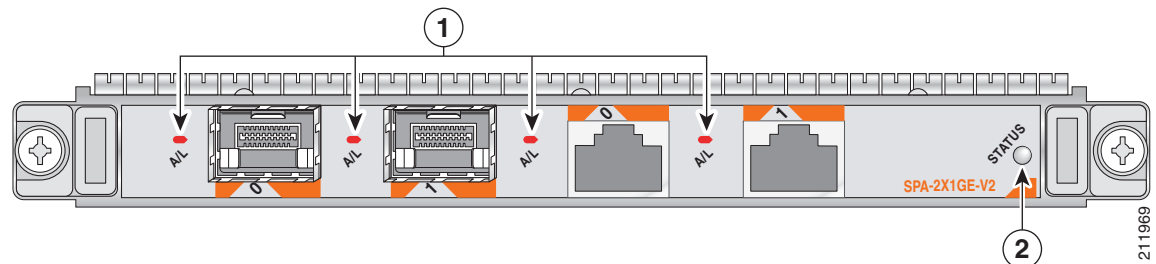

<b>1</b>	A/L (Active/Link) LED	<b>2</b>	STATUS LED
----------	-----------------------	----------	------------

Table 3-10 describes the 2-Port Copper and Optical Gigabit Ethernet SPA LEDs.

**Table 3-10** 2-Port Copper and Optical Gigabit Ethernet SPA LEDs

LED Label	Color	State	Meaning
A/L	Off	Off	Port is not enabled.
	Green	On	Port is enabled and the link is up.
	Amber	On	Port is enabled and the link is down.
STATUS	Off	Off	SPA power is off.

**Table 3-10** 2-Port Copper and Optical Gigabit Ethernet SPA LEDs (continued)

LED Label	Color	State	Meaning
	Green	On	SPA is ready and operational.
	Amber	On	SPA power is on and good, and SPA is being configured.

## 2-Port Copper and Optical Gigabit Ethernet SPA Cables, Connectors, and Pinouts

The 2-Port Copper and Optical Gigabit Ethernet SPA has two individual fiber-optic receivers that support SFP modules. Each port can send and receive traffic using the optical fiber connections.

### SFP Module Connections

The small form-factor pluggable (SFP) module is an input/output (I/O) device that plugs into the Gigabit Ethernet ports on the 2-Port Copper and Optical Gigabit Ethernet SPA, linking the port with a fiber-optic network.



#### Note

The 2-Port Copper and Optical Gigabit Ethernet SPA will only accept the SFP modules listed as supported in this document. An SFP module check is run every time an SFP module is inserted into the 2-Port Copper and Optical Gigabit Ethernet SPA and only SFP modules that pass this check will be usable by the 2-Port Copper and Optical Gigabit Ethernet SPA.

SFP modules exist for technologies other than Gigabit Ethernet and for products other than the 2-Port Copper and Optical Gigabit Ethernet SPA. However, the information in this document pertains only to SFP modules that plug into the 2-Port Copper and Optical Gigabit Ethernet SPA ports.

See the [“SFP Module and Cabling Specifications for Gigabit Ethernet SPAs”](#) section on page 3-26 for SFP module options, module specifications, and cabling specifications.

For CWDM and DWDM SFP module specifications, see the [“CWDM and DWDM SFP Modules for Gigabit Ethernet SPAs”](#) section on page 3-31.

### Cables, Connectors, and Pinouts

In addition to the two fiber-optic receivers, the 2-Port Copper and Optical Gigabit Ethernet SPA has two individual RJ-45 receptacles. You can use both interface connectors simultaneously. Each connection supports IEEE 802.3 and Ethernet 10/100BASE-T interfaces compliant with appropriate standards. Cisco does not supply Category 5 unshielded twisted pair (UTP) RJ-45 cables; these cables are available commercially.

[Figure 3-16](#) shows the RJ-45 connector. [Table 3-11](#) lists the pinouts and signals for the RJ-45 connector.

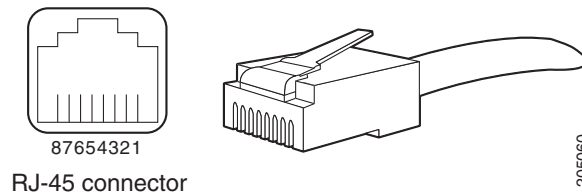

**Figure 3-16** RJ-45 Connector Pinouts, Plug, and Receptacle**Table 3-11** RJ-45 Connector Pinouts

Pin	Description
1	DA_P (bidirectional pair A, plus)
2	DA_N (bidirectional pair A, minus)
3	DB_P (bidirectional pair B, plus)
4	DC_P (bidirectional pair C, plus)
5	DC_N (bidirectional pair C, minus)
6	DB_N (bidirectional pair B, minus)
7	DD_P (bidirectional pair D, plus)
8	DD_N (bidirectional pair D, minus)

**Note**

Referring to the RJ-45 pinout in [Table 3-11](#), proper common-mode line terminations should be used for the unused Category 5 UTP cable pairs 4/5 and 7/8. Common-mode termination reduces the contributions to electromagnetic interference (EMI) and susceptibility to common-mode sources. Wire pairs 4/5 and 7/8 are actively terminated in the RJ-45 port circuitry in the 2-Port Copper and Optical Gigabit Ethernet SPA.

The 2-Port Copper and Optical Gigabit Ethernet SPA supports automatic MDI/MDIX crossover at all speeds of operation allowing the SPA to work with straight-through and crossover Ethernet cables.

## 5-Port Gigabit Ethernet SPA Overview

The following sections describe the 5-Port Gigabit Ethernet SPA:

- [5-Port Gigabit Ethernet SPA LEDs, page 3-21](#)
- [5-Port Gigabit Ethernet SPA Connectors, page 3-23](#)

### 5-Port Gigabit Ethernet SPA LEDs

The 5-Port Gigabit Ethernet SPA has two types of LEDs: an A/L LED for each port on the SPA, and one STATUS LED, as shown in [Figure 3-17](#).

**Figure 3-17** 5-Port Gigabit Ethernet SPA Faceplate

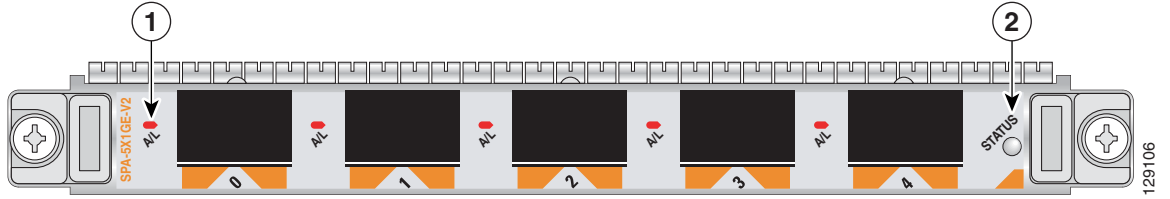

1	A/L (Active/Link) LED	2	STATUS LED
---	-----------------------	---	------------

Table 3-12 describes the 5-Port Gigabit Ethernet SPA LEDs.

**Table 3-12 5-Port Gigabit Ethernet SPA LEDs**

LED Label	Color	State	Meaning
A/L	Off	Off	Port is not enabled.
	Green	On	Port is enabled and the link is up.
	Amber	On	Port is enabled and the link is down.
STATUS	Off	Off	SPA power is off.
	Green	On	SPA is ready and operational.
	Amber	On	SPA power is on and good, and SPA is being configured.

## 5-Port Gigabit Ethernet SPA Connectors

The 5-Port Gigabit Ethernet SPA has five individual fiber-optic receivers that support SFP modules. Each port can send and receive traffic using the optical fiber connections.

### SFP Module Connections

The small form-factor pluggable (SFP) module is an input/output (I/O) device that plugs into the Gigabit Ethernet optical slots on the 5-Port Gigabit Ethernet SPA, linking the port with a 1000BASE-X fiber-optic network.



#### Note

The 5-Port Gigabit Ethernet SPA will only accept the SFP modules listed as supported in this document. An SFP module check is run every time an SFP module is inserted into the 5-Port Gigabit Ethernet SPA and only SFP modules that pass this check will be usable by the 5-Port Gigabit Ethernet SPA. SFP modules exist for technologies other than Gigabit Ethernet and for products other than the 5-Port Gigabit Ethernet SPA. However, the information in this document pertains only to SFP modules that plug into the 5-Port Gigabit Ethernet SPA ports.

See the “[SFP Module and Cabling Specifications for Gigabit Ethernet SPAs](#)” section on page 3-26 for SFP module options, module specifications, and cabling specifications.

For CWDM and DWDM SFP module specifications, see the “[CWDM and DWDM SFP Modules for Gigabit Ethernet SPAs](#)” section on page 3-31.

## 8-Port Gigabit Ethernet SPA Overview

The following sections describe the 8-port Gigabit Ethernet SPA:

- [8-Port Gigabit Ethernet SPA LEDs, page 3-24](#)
- [8-Port Gigabit Ethernet SPA Connectors, page 3-24](#)

## 8-Port Gigabit Ethernet SPA LEDs

The 8-Port Gigabit Ethernet SPA has two types of LEDs: an A/L LED for each port on the SPA, and one STATUS LED, as shown in [Figure 3-18](#).

**Figure 3-18** 8-Port Gigabit Ethernet SPA Faceplate

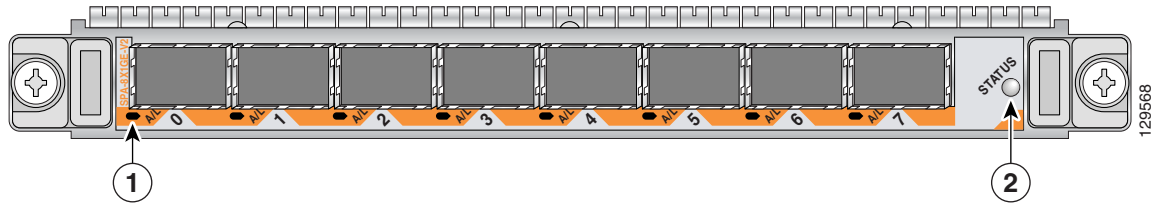

1	A/L (Active/Link) LED	2	STATUS LED
---	-----------------------	---	------------

[Table 3-13](#) describes the 8-Port Gigabit Ethernet SPA LEDs.

**Table 3-13** 8-Port Gigabit Ethernet SPA LEDs

LED Label	Color	State	Meaning
A/L	Off	Off	Port is not enabled.
	Green	On	Port is enabled and the link is up.
	Amber	On	Port is enabled and the link is down.
STATUS	Off	Off	SPA power is off.
	Green	On	SPA is ready and operational.
	Amber	On	SPA power is on and good, and the SPA is being configured.

## 8-Port Gigabit Ethernet SPA Connectors

The 8-Port Gigabit Ethernet SPA has eight individual fiber-optic receivers that support SFP modules. Each port can send and receive traffic using the optical fiber connections.

### SFP Module Connections

The small form-factor pluggable (SFP) module is an input/output (I/O) device that plugs into the Gigabit Ethernet ports on the 8-Port Gigabit Ethernet SPA, linking the port with a fiber-optic network.



#### Note

The 8-Port Gigabit Ethernet SPA will only accept the SFP modules listed as supported in this document. An SFP module check is run every time an SFP module is inserted into the 8-Port Gigabit Ethernet SPA and only SFP modules that pass this check will be usable by the 8-Port Gigabit Ethernet SPA. SFP modules exist for technologies other than Gigabit Ethernet and for products other than the 8-Port Gigabit Ethernet SPA. However, the information in this document pertains only to SFP modules that plug into the 8-Port Gigabit Ethernet SPA ports.

See the “[SFP Module and Cabling Specifications for Gigabit Ethernet SPAs](#)” section on page 3-26 for SFP module options, module specifications, and cabling specifications.

For CWDM and DWDM SFP module specifications, see the “[CWDM and DWDM SFP Modules for Gigabit Ethernet SPAs](#)” section on page 3-31.

## 10-Port Gigabit Ethernet SPA Overview

The following sections describe the 10-Port Gigabit Ethernet SPA:

- [10-Port Gigabit Ethernet SPA LEDs](#), page 3-25
- [10-Port Gigabit Ethernet SPA Connectors](#), page 3-26
- [SFP Module and Cabling Specifications for Gigabit Ethernet SPAs](#), page 3-26
- [CWDM and DWDM SFP Modules for Gigabit Ethernet SPAs](#), page 3-31

## 10-Port Gigabit Ethernet SPA LEDs

The 10-Port Gigabit Ethernet SPA has two types of LEDs: an A/L LED for each port on the SPA, and one STATUS LED, as shown in [Figure 3-19](#).

**Figure 3-19** 10-Port Gigabit Ethernet SPA Faceplate

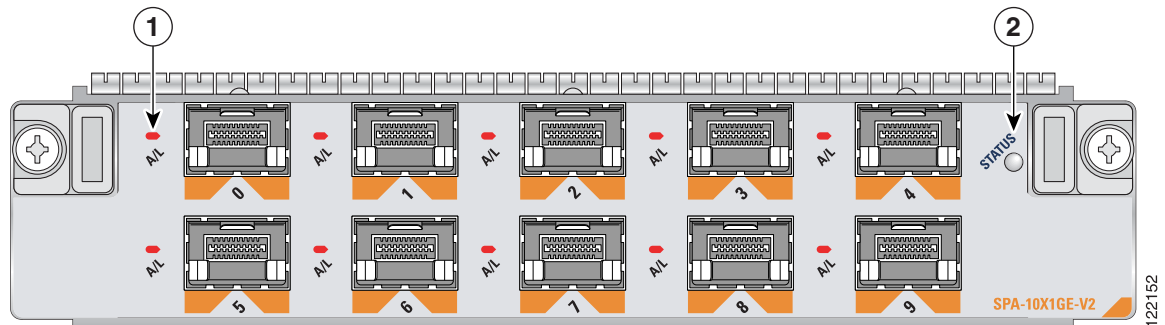

<b>1</b>	A/L (Active/Link) LED	<b>2</b>	STATUS LED
----------	-----------------------	----------	------------

[Table 3-14](#) describes the 10-Port Gigabit Ethernet SPA LEDs.

**Table 3-14** 10-Port Gigabit Ethernet SPA LEDs

LED Label	Color	State	Meaning
A/L	Off	Off	Port is not enabled.
	Green	On	Port is enabled and the link is up.
	Amber	On	Port is enabled and the link is down.
STATUS	Off	Off	SPA power is off.

**Table 3-14** 10-Port Gigabit Ethernet SPA LEDs (continued)

LED Label	Color	State	Meaning
	Green	On	SPA is ready and operational.
	Amber	On	SPA power is on and good, and the SPA is being configured.

## 10-Port Gigabit Ethernet SPA Connectors

The 10-Port Gigabit Ethernet SPA has ten electrical connectors that support SFP modules. Each port can send and receive traffic using cabling appropriate for the SFP module inserted.

### SFP Module Connections

The small form-factor pluggable (SFP) module is an input/output (I/O) device that plugs into the Gigabit Ethernet optical slots on the 10-Port Gigabit Ethernet SPA, linking the port with a 1000BASE-X fiber-optic network.



#### Note

The 10-Port Gigabit Ethernet SPA will only accept the SFP modules listed as supported in this document. An SFP module check is run every time an SFP is inserted into the 10-Port Gigabit Ethernet SPA and only SFP modules that pass this check will be usable by the 10-Port Gigabit Ethernet SPA. SFP modules exist for technologies other than Gigabit Ethernet and for products other than the 10-Port Gigabit Ethernet SPA. However, the information in this document pertains only to SFP modules that plug into the 10-Port Gigabit Ethernet SPA ports.

See the “[SFP Module and Cabling Specifications for Gigabit Ethernet SPAs](#)” section on page 3-26 for SFP module options, module specifications, and cabling specifications.

For CWDM and DWDM SFP module specifications, see the “[CWDM and DWDM SFP Modules for Gigabit Ethernet SPAs](#)” section on page 3-31.

## SFP Module and Cabling Specifications for Gigabit Ethernet SPAs

The following sections describe SFP module specifications and cabling information for the Gigabit Ethernet SPAs:

- [SFP Module Specifications, page 3-26](#)
- [SFP Module Cabling and Connection Equipment, page 3-29](#)

### SFP Module Specifications

The SFP module has a receiver port (RX) and a transmitter port (TX) that compose one optical interface. [Table 3-15](#), [Table 3-16](#), [Table 3-17](#), [Table 3-18](#), and [Table 3-19](#) provide SFP module information and specifications.

**Table 3-15 SFP Module Options for Gigabit Ethernet SPAs Using SFP Modules**

<b>SFP Module Product Number</b>	<b>SFP Module</b>	<b>Description</b>
SFP-GE-S	Short wavelength (1000BASE-SX)	Contains a Class 1 laser of 850 nm for 1000BASE-SX (short-wavelength) applications.
SFP-GE-L	Long wavelength/long haul (1000BASE-LX/LH)	Contains a Class 1 laser of 1310 nm for 1000BASE-LX/LH (long-wavelength) applications.
SFP-GE-Z	Extended wavelength (1000BASE-ZX)	Contains a Class 1 laser of 1550 nm for 1000BASE-ZX (extended-wavelength) applications.
SFP-GE-T	Cisco 1000BASE-T SFP	The 1000BASE-T SFP module operates on standard Category 5 wiring of up to 328 feet (100 m) link length.
GLC-TE	Cisco 1000BASE-T SFP Module	The Cisco 1000BASE-T SFP Module supports bidirectional serial data over shielded and unshielded twisted pair, category 5 cables.
GLC-GE-100FX=	Cisco 100BASE-FX SFP for Gigabit SFP ports	The 100BASE-FX SFP module for Gigabit Ethernet ports operates on ordinary multimode fiber-optic (MMF) link spans up to 6562 feet (2 km) long with a 1310 nm wavelength.
XFP-10GER-192IR+	Cisco Multirate 10GBASE-ER and OC-192/STM-64 IR-2 XFP Module	The Cisco Multirate 10GBASE-ER and OC-192/STM-64 IR-2 is single-mode intermediate-reach (IR) XFP module.
GLC-SX-MMD (=)	1000BASE-SX SFP transceiver module	The 1000BASE-SX SFP transceiver module is DOM capable, and operates on multimode fiber-optic (MMF) with 850 nm wavelength.
GLC-LH-SMD (=)	1000BASE-LX/LH SFP transceiver module	The 1000BASE-LX/LH SFP transceiver module is DOM capable, and operates on singlemode fiber-optic (SMF) of up to 10-Km link length with 1310 nm wavelength.
GLC-ZX-SMD	1000BASE-ZX SFP transceiver module	Contains a Class 1 laser of 1550 nm for 1000BASE-ZX (extended-wavelength) applications.

**Table 3-16 SFP Module Specifications**

Specification	Description
Wavelength	SFP-GE-S: 770 to 860 nm SFP-GE-L: 1270 to 1355 nm SFP-GE-Z: 1500 to 1580 nm SFP-GE-T: N/A  GLC-TE: N/A GLC-GE-100FX: 1270 to 1380 nm GLC-ZX-SMD: 1550 nm
Cabling distance (maximum)	SFP-GE-S: 1640 feet (500 m) on 50/125um MMF; 984 feet (300 m) on 62.5/125um MMF SFP-GE-L: 6.2 miles (10 km) SFP-GE-Z: 49.7 miles (80 km) SFP-GE-T: 328 feet (100 m)  GLC-TE: 328 feet (100 m) GLC-GE-100FX: 6562 feet (2 km) GLC-ZX-SMD: 49.7 miles (80 km)
Operating case temperature range	SFP-GE-S: 23 to 185°F (–5 to 85°C) SFP-GE-L: 23 to 185°F (–5 to 85°C) SFP-GE-Z: 23 to 185°F (–5 to 85°C) SFP-GE-T: 23 to 185°F (–5 to 85°C)  GLC-TE: 23 to 185°F (–5 to 85°C) GLC-GE-100FX: 23 to 185°F (–5 to 85°C) GLC-ZX-SMD: 23 to 185°F (–5 to 85°C)
Storage temperature range	SFP-GE-S: –40 to 185°F (–40 to 85°C) SFP-GE-L: –40 to 185°F (–40 to 85°C) SFP-GE-Z: –40 to 185°F (–40 to 85°C) SFP-GE-T: –40 to 185°F (–40 to 85°C)  GLC-TE: –40 to 185°F (–40 to 85°C) GLC-GE-100FX: –40 to 185°F (–40 to 80°C) GLC-ZX-SMD: –40 to 185°F (–40 to 85°C)
Supply voltage range	SFP-GE-S: 3.1 to 3.5 V SFP-GE-L: 3.1 to 3.5 V SFP-GE-Z: 3.1 to 3.5 V SFP-GE-T: 3.1 to 3.5 V  GLC-TE: 3.1 to 3.5 V GLC-GE-100FX: 3.3 to 3.5 V GLC-ZX-SMD: 3.1 to 3.5 V

**SFP-GE-S Modules**

The 1000BASE-SX (short-wavelength) module operates on standard multimode fiber-optic link spans of up to 1640 feet (500 m) on 50/125um multimode fiber (MMF) and 984 feet (300 m) on 62.5/125um MMF.



## SFP-GE-L Modules

The 1000BASE-LX/LH (long-wavelength/long-haul) module interfaces fully comply with the IEEE 802.3z 1000BASE-LX standard. However, their higher optical quality allows them to reach 6.2 miles (10 km) over single-mode fiber (SMF) versus the 3.1 miles (5 km) specified in the standard.

## SFP-GE-Z Modules

The 1000BASE-ZX (extended-wavelength) module operates on ordinary single-mode fiber-optic link spans of up to 49.7 miles (80 km). Link spans of up to 62.1 miles (100 km) are possible using premium single-mode fiber or dispersion-shifted single-mode fiber. (Premium single-mode fiber has a lower attenuation per unit length than ordinary single-mode fiber; dispersion-shifted single-mode fiber has both lower attenuation and less dispersion.)

The 1000BASE-ZX module must be coupled to single-mode fiber-optic cable, which is the type of cable typically used in long-haul telecommunications applications. The 1000BASE-ZX module does not operate correctly when coupled to multimode fiber, and it is not intended to be used in environments in which multimode fiber is frequently used (for example, building backbones or horizontal cabling).

The 1000BASE-ZX module is intended to be used as a Physical Medium Dependent (PMD) component for Gigabit Ethernet interfaces found on various switch and router products. It operates at a signaling rate of 1250 Mbaud, transmitting and receiving 8B/10B encoded data.

When shorter lengths of single-mode fiber are used, it may be necessary to insert an inline optical attenuator in the link to avoid overloading the receiver. Use the following guidelines:

- Insert a 10-dB inline optical attenuator between the fiber-optic cable plant and the receiving port on the 1000BASE-ZX module at each end of the link whenever the fiber-optic cable span is less than 15.5 miles (25 km).
- Insert a 5-dB inline optical attenuator between the fiber-optic cable plant and the receiving port on the 1000BASE-ZX module at each end of the link whenever the fiber-optic cable span is equal to or greater than 15.5 miles (25 km) but less than 31 miles (50 km).

## SFP-GE-T Modules

The 1000BASE-T SFP module (SFP-GE-T) is compliant with IEEE 802.3:2000 and plugs into a standard Gigabit Ethernet SFP module port. It operates on standard Category 5 wiring and has an RJ-45 connector. The SFP-GE-T maximum cabling distance is 328 feet (100 m).

The SFP-GE-T is hot-swappable. Autonegotiation is not supported. The SFP-GE-T module supports 10/100/1000 speeds, which must be explicitly configured using the **speed** command. Only full-duplex mode is supported, which must be configured using the **duplex full** command.

## GLC-TE Modules

The 1000BASE-T SFP module (GLC-TE) sends bidirectional serial data over shielded and unshielded twisted pair, category 5 cables. Autonegotiation is not supported. It has a RJ-45 connector that can work in 10/100/1000BASE-T mode with SGMII host.

## SFP Module Cabling and Connection Equipment

[Table 3-17](#) provides cabling specifications for the SFP modules that can be installed on the Gigabit Ethernet SPAs. Note that all SFP ports have LC-type connectors.

The minimum cable distance for the SFP-GE-S is 6.5 feet (2 m), and the minimum link distance for the SFP-GE-Z is 6.2 miles (10 km) with an 8-dB attenuator installed at each end of the link. Without attenuators, the minimum link distance for the SFP-GE-Z is 24.9 miles (40 km).

**Table 3-17 SFP Module Port Cabling Specifications**

SFP Modules	Wavelength (nm)	Fiber Type	Core Size (micron)	Modal Bandwidth (MHz/km)	Maximum Cable Distance
SFP-GE-S	850	MMF <sup>1</sup>	62.5	160	722 ft (220 m)
			62.5	200	984 ft (300 m)
			50.0	400	1640 ft (500 m)
			50.0	500	1804 ft (550 m)
SFP-GE-L	1300	MMF <sup>2</sup> and SMF	62.5	500	1804 ft (550 m)
			50.0	400	1804 ft (550 m)
			50.0	500	1804 ft (550 m)
			9/10	—	6.2 miles (10 km)
SFP-GE-Z	1550	SMF	9/10	—	49.7 miles (80 km)
		SMF <sup>3</sup>	8	—	62.1 miles (100 km)
SFP-GE-T	N/A	Copper	N/A	N/A	328 ft (100 m)
GLC-TE	N/A	Copper	N/A	N/A	328 ft (100 m)
GLC-GE-100FX =	1310	MMF	62.5 62.5 50.0 50.0	500	6562 ft (2 km)
GLC-ZX-SMD	1550	SMF	9/10	—	49.7 miles (80 km)
			8	—	62.1 miles (100 km)

1. Multimode fiber (MMF) only.
2. A mode-conditioning patch cord is required. When using the SFP-GE-L with 62.5-micron diameter MMF, you must install a mode-conditioning patch cord between the SFP module and the MMF cable on both the transmit end and the receive end of the link when link distances are greater than 984 ft (300 m).
3. Dispersion-shifted single-mode fiber-optic cable.



**Note**

The 1000BASE-ZX SFP modules provide an optical power budget of 21.5 dB. You should measure your cable plant with an optical loss test set to verify that the optical loss of the cable plant (including connectors and splices) is less than or equal to 21.5 dB. The optical loss measurement must be performed with a 1550-nm light source.

## CWDM and DWDM SFP Modules for Gigabit Ethernet SPAs

Specifications for the coarse wave division multiplexer (CWDM) and dense wave division multiplexer (DWDM) SFP modules are given in the following sections:

- [CWDM SFP Module Specifications for All Gigabit Ethernet SPAs Using SFP Modules, page 3-31](#)
- [DWDM SFP Module Specifications, page 3-32](#)

### CWDM SFP Module Specifications for All Gigabit Ethernet SPAs Using SFP Modules

Table 3-18 provides CWDM SFP module specifications for all Gigabit Ethernet SPAs using SFP modules (but not those Gigabit Ethernet SPAs using XFP modules).

**Table 3-18** CWDM SFP Module Specifications

CWDM Product Number	CWDM Module	Color
CWDM-SFP-1470	Cisco CWDM 1470-nm SFP module; Gigabit Ethernet and 1- and 2-Gb Fibre Channel	Gray
CWDM-SFP-1490	Cisco CWDM 1490-nm SFP module; Gigabit Ethernet and 1- and 2-Gb Fibre Channel	Violet
CWDM-SFP-1510	Cisco CWDM 1510-nm SFP module; Gigabit Ethernet and 1- and 2-Gb Fibre Channel	Blue
CWDM-SFP-1530	Cisco CWDM 1530-nm SFP module; Gigabit Ethernet and 1- and 2-Gb Fibre Channel	Green
CWDM-SFP-1550	Cisco CWDM 1550-nm SFP module; Gigabit Ethernet and 1- and 2-Gb Fibre Channel	Yellow
CWDM-SFP-1570	Cisco CWDM 1570-nm SFP module; Gigabit Ethernet and 1- and 2-Gb Fibre Channel	Orange
CWDM-SFP-1590	Cisco CWDM 1590-nm SFP module; Gigabit Ethernet and 1- and 2-Gb Fibre Channel	Red
CWDM-SFP-1610	Cisco CWDM 1610-nm SFP module; Gigabit Ethernet and 1- and 2-Gb Fibre Channel	Brown

## DWDM SFP Module Specifications

Table 3-19 provides DWDM SFP module specifications.



### Note

The DWDM SFP modules are only supported on the following SPAs: 2-Port Gigabit Ethernet SPA, 5-Port Gigabit Ethernet SPA, 8-Port Gigabit Ethernet SPA, 10-Port Gigabit Ethernet SPA.

**Table 3-19 DWDM SFP Module Specifications**

DWDM Product Number	DWDM Module	ITU Channel
DWDM-SFP-6061=	1000BASE-DWDM 1560.61 nm SFP module (100-GHz ITU grid)	21
DWDM-SFP-5979=	1000BASE-DWDM 1559.79 nm SFP module (100-GHz ITU grid)	22
DWDM-SFP-5898=	1000BASE-DWDM 1558.98 nm SFP module (100-GHz ITU grid)	23
DWDM-SFP-5817=	1000BASE-DWDM 1558.17 nm SFP module (100-GHz ITU grid)	24
DWDM-SFP-5655=	1000BASE-DWDM 1556.55 nm SFP module (100-GHz ITU grid)	26
DWDM-SFP-5575=	1000BASE-DWDM 1555.75 nm SFP module (100-GHz ITU grid)	27
DWDM-SFP-5494=	1000BASE-DWDM 1554.94 nm SFP module (100-GHz ITU grid)	28
DWDM-SFP-5413=	1000BASE-DWDM 1554.13 nm SFP module (100-GHz ITU grid)	29
DWDM-SFP-5252=	1000BASE-DWDM 1552.52 nm SFP module (100-GHz ITU grid)	31
DWDM-SFP-5172=	1000BASE-DWDM 1551.72 nm SFP module (100-GHz ITU grid)	32
DWDM-SFP-5092=	1000BASE-DWDM 1550.92 nm SFP module (100-GHz ITU grid)	33
DWDM-SFP-5012=	1000BASE-DWDM 1550.12 nm SFP module (100-GHz ITU grid)	34
DWDM-SFP-4851=	1000BASE-DWDM 1548.51 nm SFP module (100-GHz ITU grid)	36
DWDM-SFP-4772=	1000BASE-DWDM 1547.72 nm SFP module (100-GHz ITU grid)	37
DWDM-SFP-4692=	1000BASE-DWDM 1546.92 nm SFP module (100-GHz ITU grid)	38
DWDM-SFP-4612=	1000BASE-DWDM 1546.12 nm SFP module (100-GHz ITU grid)	39
DWDM-SFP-4453=	1000BASE-DWDM 1544.53 nm SFP module (100-GHz ITU grid)	41
DWDM-SFP-4373=	1000BASE-DWDM 1543.73 nm SFP module (100-GHz ITU grid)	42
DWDM-SFP-4294=	1000BASE-DWDM 1542.94 nm SFP module (100-GHz ITU grid)	43
DWDM-SFP-4214=	1000BASE-DWDM 1542.14 nm SFP module (100-GHz ITU grid)	44
DWDM-SFP-4056=	1000BASE-DWDM 1540.56 nm SFP module (100-GHz ITU grid)	46
DWDM-SFP-3977=	1000BASE-DWDM 1539.77 nm SFP module (100-GHz ITU grid)	47
DWDM-SFP-3898=	1000BASE-DWDM 1538.98 nm SFP module (100-GHz ITU grid)	48
DWDM-SFP-3819=	1000BASE-DWDM 1538.19 nm SFP module (100-GHz ITU grid)	49
DWDM-SFP-3661=	1000BASE-DWDM 1536.61 nm SFP module (100-GHz ITU grid)	51
DWDM-SFP-3582=	1000BASE-DWDM 1535.82 nm SFP module (100-GHz ITU grid)	52
DWDM-SFP-3504=	1000BASE-DWDM 1535.04 nm SFP module (100-GHz ITU grid)	53
DWDM-SFP-3425=	1000BASE-DWDM 1534.25 nm SFP module (100-GHz ITU grid)	54
DWDM-SFP-3268=	1000BASE-DWDM 1532.68 nm SFP module (100-GHz ITU grid)	56

**Table 3-19** DWDM SFP Module Specifications (continued)

DWDM Product Number	DWDM Module	ITU Channel
DWDM-SFP-3190=	1000BASE-DWDM 1531.90 nm SFP module (100-GHz ITU grid)	57
DWDM-SFP-3112=	1000BASE-DWDM 1531.12 nm SFP module (100-GHz ITU grid)	58
DWDM-SFP-3033=	1000BASE-DWDM 1530.33 nm SFP module (100-GHz ITU grid)	59

## 2-Port Gigabit Synchronous Ethernet SPA Overview

The following sections describe the 2-Port Gigabit Synchronous Ethernet SPA:

- [2-Port Gigabit Synchronous Ethernet SPA LEDs, page 3-33](#)
- [2-Port Gigabit Synchronous Ethernet SPA Interface Specifications, page 3-34](#)
- [2-Port Gigabit Synchronous Ethernet SPA Cables and Connectors, page 3-35](#)

## 2-Port Gigabit Synchronous Ethernet SPA LEDs

The 2-Port Gigabit Synchronous Ethernet SPA is a half-height SPA with these LEDs:

- SPA status LED
- Line status LED - A bi-color, surface-mount, right-angle LED dedicated to each SFP, RJ-45 and coax connector to indicate port status
- Debug LED

[Table 3-20](#) describes the 2-Port Gigabit Synchronous Ethernet SPA LEDs.

**Table 3-20** 2-Port Gigabit Synchronous Ethernet SPA LEDs

LED Label	Color	Meaning
SPA status LED	Off	The SPA is powered off.
	Amber	The SPA is powered on but initializing.
	Green	The SPA is powered on and operational.
	Amber and green	This state is unused and its meaning is undefined. Port is not enabled.
Line Status LED	Off	Port is not enabled by the software.
	Amber	Port is enabled by the software, but there is a problem with the link.
	Green	Port is enabled by the software, and the link is valid.
	Amber and green	This state is unused and its meaning is undefined.
Debug LED	Green	Indicates a SPA OK status to the host.

Figure 3-20 2-Port Gigabit Ethernet Synchronous Ethernet SPA Faceplate

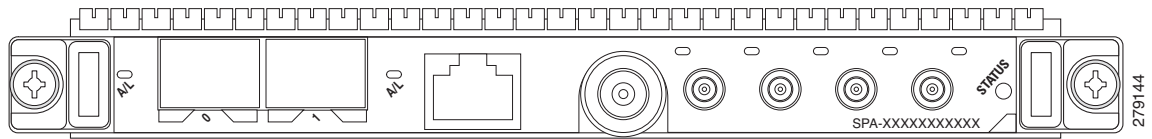

## 2-Port Gigabit Synchronous Ethernet SPA Interface Specifications

The 2-Port Gigabit Synchronous Ethernet SPA is compatible with the 2-Port Gigabit Ethernet SPA on all platforms and provides additional services of clock frequency and time of day synchronization. The 2-Port Gigabit Synchronous Ethernet SPA uses new technologies such as Synchronous Ethernet (SyncE), ESMC, and IEEE1588v2.

However, the 2-Port Gigabit Synchronous Ethernet SPA supports only optical interfaces. As a result the 2-Port Gigabit Synchronous Ethernet SPA does not support multiple line speeds (10/100/1000 Mbps) on the 2-Port Gigabit Ethernet SPA.

Synchronous Ethernet is a layer 1 technology which delivers a very accurate frequency reference, but it doesn't address time synchronization. IEEE1588v2 defines a Precision Time Protocol (PTP), which distributes accurate timing information (both clock frequency and time of day) over packet networks. 2-Port Gigabit Synchronous Ethernet SPA hardware supports IEEE1588v2, either as a client or server. The 2-Port Gigabit Synchronous Ethernet SPA has these hardware capabilities to support the 1588v2 protocol stack:

- Classification and forwarding of 1588v2 protocol packets.
- Hardware time stamping.



**Note** The 2-Port Gigabit Synchronous Ethernet SPA hardware is the same for all configurations of the product.

Table 3-21 describes key interface specifications on the 2-Port Gigabit Synchronous Ethernet SPA.

Table 3-21 Interface Specification for 2-Port Gigabit Synchronous Ethernet SPA

Specification	Description
Synchronous Ethernet support	Yes
Interface Type and Density	2x1 GE
Local Timing Interfaces	Input; Output
Local Timing Frequency	1.544 MHz / 2.048 MHz
BITS Interface Support	In; Out
SSM Support	Yes

Specification	Description
IEEE 1588v2	Yes
NTPv4	Yes

## Power Supply

The 2-Gigabit Synchronous Ethernet SPA extracts 18.854 watts maximum. The actual Lab measurements at room temperature result in only around 10.5 watts maximum.

## Standards Compliance

The 2-Port Gigabit Synchronous Ethernet SPA complies with these standard specifications:

- ITU-T G.8261 (2008) specifications for SyncE support on ethernet interfaces.
- ITU-T G.8262 (OPTIONS 1 AND 2) for platform timing support and performance.
- IETF TICTOC telecom profile support for performance.
- ITU-T G.8261, G.8262, G.823, G.824, G.825, O.171, and O.172 for clock jitter and wander specifications.

## 2-Port Gigabit Synchronous Ethernet SPA Cables and Connectors

### SFP Optics Module

The 2-Port Gigabit Synchronous Ethernet SPA uses a small form-factor pluggable (SFP) optical transceiver module installed in each port.

**Figure 3-21** SFP Optics Module

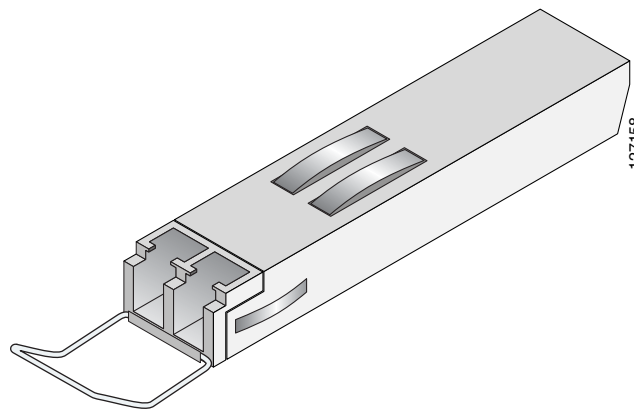

Long-range SFP optical transceiver modules (for long-reach configurations) cannot be connected back-to-back without using an attenuator between the two of them.

## BITS Interface

The BITS/SSU is a bidirectional interface implemented on the 2-Gigabit Synchronous Ethernet SPA. It relays a clock to an SSU and in return receives a clock without the wander. This interface also allows the 2-Port Gigabit Synchronous Ethernet SPA to be a system resource for older platforms that are not BITS capable.

## 2-Port, 4-Port, and 8-Port OC-3c/STM-1 POS SPA Overview

The 2-Port and 4-Port OC-3c/STM-1 POS SPA is a single-height SPA that installs into one SIP subslot. The 2-Port and 4-Port OC-3c/STM-1 POS SPA with small form-factor pluggable (SFP) optical transceiver modules provides SONET and SDH network connectivity with a per-port bandwidth of 155.52 Mbps. The 2-Port and 4-Port OC-3c/ST-1 POS SPA operates at quarter rate. The 8-Port OC-3c/STM-1 POS SPA operates at half rate.



### Note

When SFP modules are replaced, the SPA interface retains any previously defined configurations. These configurations include settings for IP address, clock source, loopback, CRC, and POS flags.

For more information about SPAs and their compatibility with SIPs and modular optics, see the “[SIP and SPA Compatibility](#)” section on page 1-3.

The following sections describe the 2-Port and 4-Port OC-3c/STM-1 POS SPA:

- [2-Port and 4-Port OC-3c/STM-1 POS SPA LEDs](#), page 3-36
- [2-Port and 4-Port OC-3c/STM-1 POS SPA Interface Specifications](#), page 3-37
- [2-Port and 4-Port OC-3c/STM-1 POS SPA Optical Transceiver Modules and Cables](#), page 3-37

## 2-Port and 4-Port OC-3c/STM-1 POS SPA LEDs

The 2-Port and 4-Port OC-3c/STM-1 POS SPA has three types of LEDs: two LEDs for each port on the SPA, and one STATUS LED, as shown in [Figure 3-22](#).

**Figure 3-22** 4-Port OC-3c/STM-1 POS SPA Faceplate

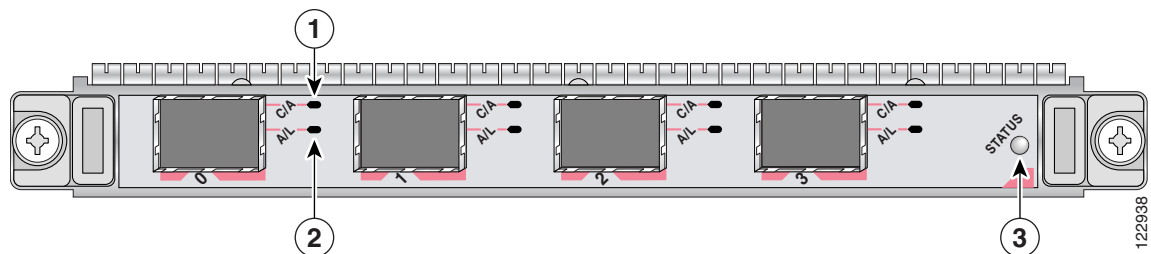

1	C/A (Carrier/Alarm) LED	3	STATUS LED
2	A/L (Active/Loopback) LED		



Table 3-22 describes the 2-Port and 4-Port OC-3c/STM-1 POS SPA LEDs.

**Table 3-22 2-Port and 4-Port OC-3c/STM-1 POS SPA LEDs**

LED Label	Color	State	Meaning
C/A	Off	Off	SONET controller is shut down.
	Green	On	Port is enabled by software, and there is a valid SONET signal without any alarms.
	Amber	On	Port is enabled by software, and there is at least one alarm.
A/L	Off	Off	Interface is shut down.
	Green	On	Port is enabled by software, and loopback is off.
	Amber	On	Port is enabled by software, and loopback is on.
STATUS	Off	Off	SPA power is off.
	Green	On	SPA is ready and operational.
	Amber	On	SPA power is on and good, and the SPA is being configured.

## 2-Port and 4-Port OC-3c/STM-1 POS SPA Interface Specifications

The framer processes incoming and outgoing SONET or SDH frames. The framer operates at OC-3c/STM-1 line rates (155.52 Mbps).

Packet data is transported with a user-configured encapsulation (such as Point-to-Point Protocol [PPP]), and is mapped into the STS-3c/STM-1 frame.

The 2-Port and 4-Port OC-3c/STM-1 POS SPA interface complies with the following RFCs:

- RFC 1662, *PPP in HDLC-like Framing*
- RFC 2427, *Multiprotocol Interconnect over Frame Relay*
- RFC 2615, *PPP over SONET/SDH*

## 2-Port and 4-Port OC-3c/STM-1 POS SPA Optical Transceiver Modules and Cables

The 2-Port and 4-Port OC-3c/STM-1 POS SPA uses a small form-factor pluggable (SFP) optical transceiver module installed in each port for SONET and SDH single-mode and multimode optical fiber connection (see [Figure 3-23](#)).

Cisco qualifies the optics that are approved for use with its SPAs. The 2-Port and 4-Port OC-3c/STM-1 POS SPA supports the following types of optical transceiver modules:

- Multimode (MM) SFP module—SFP-OC3-MM
- Short-reach (SR) SFP module—SFP-OC3-SR
- Intermediate-reach (IR) SFP module (15 km)—SFP-OC3-IR1
- Long-reach (LR) SFP module (40 km)—SFP-OC3-LR1
- Long-reach (LR) SFP module (80 km)—SFP-OC3-LR2

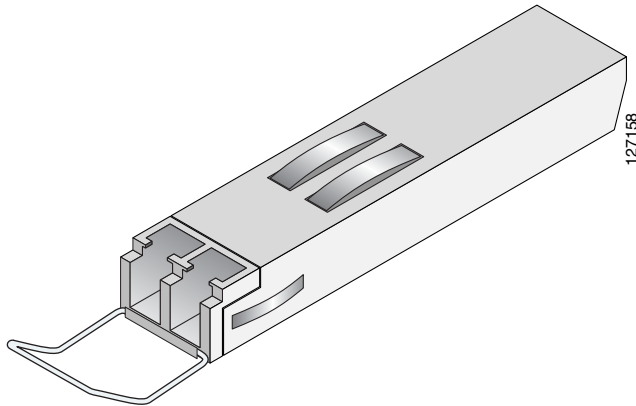
**Figure 3-23 SFP Optics Module**

The SFP optical transceiver modules used with the 2-Port and 4-Port OC-3c/STM-1 POS SPA provide the following optical fiber options:

- Multimode—155-Mbps, OC-3c/STM-1 optical fiber (SONET STS-3c or SDH STM-1)  
Use a multimode optical fiber that has a core/cladding diameter of 62.5/125 microns.
- Single-mode—155-Mbps, OC-3c/STM-1 optical fiber (SONET STS-3c or SDH STM-1)  
Use a single-mode optical fiber that has a modal-field diameter of  $8.7 \pm 0.5$  microns. (Nominal diameter is approximately 10/125 microns.)

For single-mode and multimode optical fiber connections, you can use either a duplex LC-type cable (see [Figure 3-24](#)) or two simplex LC-type cables, one for transmit (TX) and one for receive (RX).

Use single-mode (for intermediate- or long-reach configurations) or multimode optical fiber cable to connect your router to a network or to connect two 2-Port and 4-Port OC-3c/STM-1 POS SPA-equipped routers back-to-back.

Long-range SFP optical transceiver modules (for long-reach configurations) cannot be connected back-to-back without using an attenuator between them.

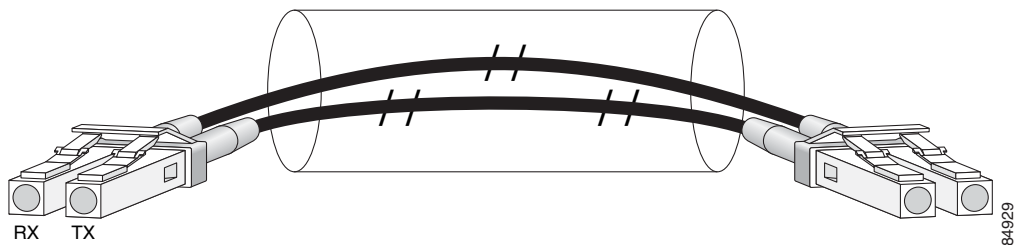
**Figure 3-24 LC-Type Cables**

## 1-Port and 2-Port OC-12c/STM-1 POS SPA

Effective from Cisco IOS XE Fuji 16.7.1 release, software based licensing support is provided for the following SPAs:

### 2 port OC12 SPA (SPA-2XOC12-POS)

When any one port is free to use, only one license is required to use the remaining port.

License Request

**Step1:** Unshut Port0-No license is requested

**Step2:** Unshut Port1-One unit of license is required

License Release

Assuming all ports are in unshut state (One unit of license is already consumed)

**Step1:** Shut Port0-One license is released (After this operation, Port1 is in unshut state and zero unit of license is consumed)

Use the show license summary to check for details after enabling Smart Licensing.

Device# show license summary

Smart Licensing is ENABLED

Registration:

Status: REGISTERED

Smart Account: XYZ\_1

Virtual Account: XYZ\_2

Export-Controlled Functionality: Allowed

Last Renewal Attempt: None

Next Renewal Attempt: Feb 19 14:01:25 2018 IST

License Authorization:

Status: AUTHORIZED

Last Communication Attempt: SUCCESS

Next Communication Attempt: Sep 22 14:01:32 2017 IST

License Usage:

License Entitlement tag Count Status

-----  
ASR\_1000\_OC3-2-4 (ASR\_1000\_OC3-2-4) 1 AUTHORIZED

ASR\_1000\_OC12-1-2 (ASR\_1000\_OC12-1-2) 1 AUTHORIZED

OC12-POS SPA:

When a two port OC12 POS SPA is ordered, SPA-2XOC12-POS is shipped  
(One unit of OC12 license is added to the Smart License account)

When a one port OC12 POS SPA is ordered, SPA-2XOC12-POS is shipped  
(No license added to the Smart License account)

Note: At a later point of time, to use the second port, one license can be purchased:

"L-FLASR1-OC12-1-2="

(One unit of OC12 license is added to the Smart License account)

## OC-3 Module Connections

Table 3-23 shows the OC-3 specifications of the optics on the 2-Port and 4-Port OC-3c/STM-1 POS SPA.

**Table 3-23 OC-3 Specifications**

Specification	Description
Wavelength	OC-3 MM: 1270 nm to 1380 nm OC-3 SR: 1260 nm to 1360 nm OC-3 IR-1: 1261 nm to 1360 nm OC-3 LR-1: 1263 nm to 1360 nm OC-3 LR-2: 1480 nm to 1580 nm
Cabling distance (maximum)	OC-3 MM: 2 km (1.2 miles) OC-3 SR: 2 km (1.2 miles) OC-3 IR-1: 15 km (9.3 miles) OC-3 LR-1: 40 km (24.8 miles) OC-3 LR-2: 80 km (49.7 miles)
Operating case temperature range	OC-3 MM: 23 to 185°F (–5 to 85°C) OC-3 SR: 23 to 185°F (–5 to 85°C) OC-3 IR-1: 23 to 185°F (–5 to 85°C) OC-3 LR-1: 23 to 185°F (–5 to 85°C) OC-3 LR-2: 23 to 185°F (–5 to 85°C)
TX power	OC-3 MM: –19 to –14 dBm OC-3 SR: –15 to –8 dBm OC-3 IR-1: –15 to –8 dBm OC-3 LR-1: –5 to 0 dBm OC-3 LR-2: –5 to 0 dBm
Receiver sensitivity (maximum)	OC-3 MM: –30 dBm OC-3 SR: –23 dBm OC-3 IR-1: –28 dBm OC-3 LR-1: –34 dBm OC-3 LR-2: –34 dBm
RX overload	OC-3 MM: –5 dBm OC-3 SR: –8 dBm OC-3 IR-1: –8 dBm OC-3 LR-1: –10 dBm OC-3 LR-2: –10 dBm
Maximum receiver power damage	OC-3 MM: 5 dBm OC-3 SR: 5 dBm OC-3 IR-1: 5 dBm OC-3 LR-1: 5 dBm OC-3 LR-2: 5 dBm

# 1-Port OC-48c/STM-16 POS SPA Overview

The 1-Port OC-48c/STM-16 POS SPA provides Packet over SONET (POS) network connectivity with a bandwidth of 9.95 Gbps.

The following sections describe the 1-Port OC-48c/STM-16 POS SPA:

- [1-Port OC-48c/STM-16 POS SPA LEDs, page 3-41](#)
- [1-Port OC-48c/STM-16 POS SPA Interface Specifications, page 3-42](#)
- [1-Port OC-48c/STM-16 POS SPA Optical Transceiver Modules, Connectors, and Cables, page 3-43](#)

## 1-Port OC-48c/STM-16 POS SPA LEDs

The 1-Port OC-48c/STM-16 POS SPA has eight LEDs, as shown in [Figure 3-25](#).

**Figure 3-25** 1-Port OC-48c/STM-16 POS SPA Faceplate

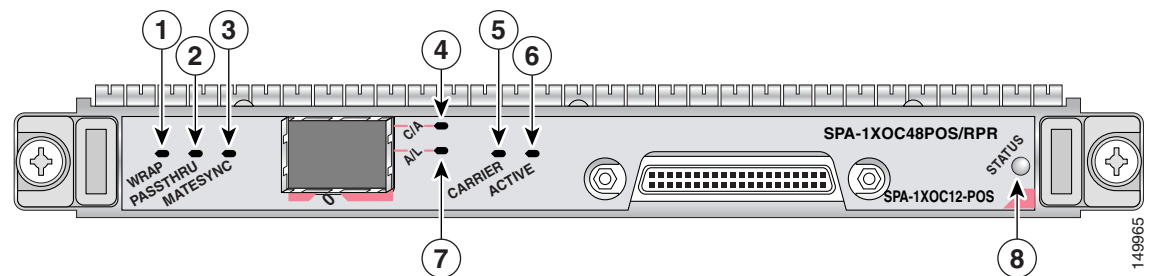

1	WRAP LED	5	CARRIER LED
2	PASSTHRU LED	6	ACTIVE LED
3	MATESYNC LED	7	A/L (Active/Loopback) LED
4	C/A (Carrier/Alarm) LED	8	STATUS LED



### Note

The WRAP, PASSTHRU, and MATESYNC LEDs apply to the SPA in RPR/SRP mode only.

[Table 3-24](#) describes the 1-Port OC-48c/STM-16 POS SPA LEDs.

**Table 3-24** 1-Port OC-48c/STM-16 POS SPA LEDs

LED Label	Color	State	Meaning
WRAP	Off	Off	Port is not in wrap mode.
	Green	On	Port is in wrap mode somewhere on the ring.
	Amber	On	Port is in wrap mode locally.
PASSTHRU	Off	Off	Port is not in pass-through mode.
	Amber	On	Port is in pass-through mode.
MATESYNC	Off	Off	Mate port is not synchronized.

**Table 3-24 1-Port OC-48c/STM-16 POS SPA LEDs (continued)**

LED Label	Color	State	Meaning
	Green	On	Mate port is synchronized.
C/A	Off	Off	Port is not enabled by software.
	Green	On	Port is enabled by software.
	Amber	On	Port is enabled by software, and there is at least one alarm.
A/L	Off	Off	Port is not enabled by software.
	Green	On	Port is enabled by software, loopback is off.
	Amber	On	Port is enabled by software, loopback is on.
CARRIER	Off	Off	Port is not enabled by software.
	Green	On	Port is enabled by software, and there is a valid SONET signal without any alarms.
	Amber	On	Port is enabled by software, and there is at least one alarm (LOS, LOF, RDI, and so on).
		Blinking	
ACTIVE	Off	Off	Port is not enabled by software.
	Green	On	Port is enabled by software, and loopback is off.
	Amber	On	Port is enabled by software, and loopback is on.
STATUS	Off	Off	SPA power is off.
	Green	On	SPA is ready and operational.
	Amber	On	SPA power is on and good, and the SPA is being configured.

## 1-Port OC-48c/STM-16 POS SPA Interface Specifications

The framer processes incoming and outgoing SONET or SDH frames. The framer operates at OC-48c/STM-64 line rates (9.95 Gbps).

Packet data is transported with a user-configured encapsulation (such as Point-to-Point Protocol [PPP]), and is mapped into the STS-48/STM-64 frame.

The 1-Port OC-48c/STM-16 POS SPA interface is compliant with the following RFCs:

- RFC 1662, *PPP in HDLC-like Framing*
- RFC 2615, *PPP over SONET/SDH*

## 1-Port OC-48c/STM-16 POS SPA Optical Transceiver Modules, Connectors, and Cables

The 1-Port OC-48c/STM-16 POS SPA uses a single-mode, 9.95 Gbps, OC-48 optical fiber (SONET STS-48) optical transceiver module for SONET connection to the network.

The 1-Port OC-48c/STM-16 POS SPA supports the following types of optical transceiver modules:

- Single-mode short-reach (SR) SFP module—SFP-OC48-SR
- Single-mode intermediate-reach (IR) SFP module—SFP-OC48-IR1
- Single-mode long-reach (LR) SFP module—SFP-OC48-LR2

Use a single-mode optical fiber that has a modal-field diameter of  $8.7 \pm 0.5$  microns (nominal diameter is approximately 10/125 microns) to connect your router to a network.

Figure 3-26 shows the cable type for use with the XFP optical transceiver module on the 1-Port OC-48c/STM-16 POS SPA.

**Figure 3-26** LC-Type Cable for the SFP Optical Transceiver Modules

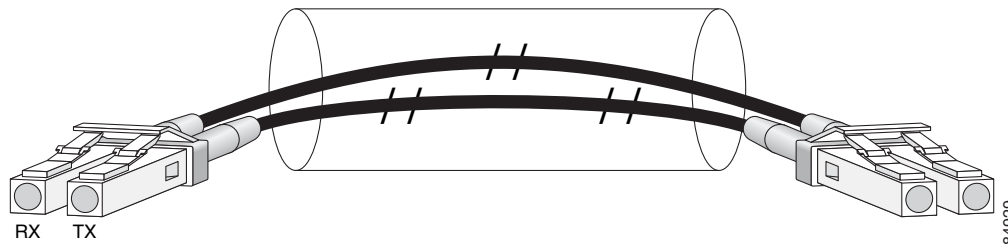

**Note**

The 40-pin connector on the 1-Port OC-48c/STM-16 POS SPA is used for resilient packet ring (RPR) connections.

## 2-Port and 4-Port OC-48c/STM-16 POS SPA Overview

The following sections describe the 2-Port and 4-Port OC-48c/STM-16 POS SPA:

- [2-Port and 4-Port OC-48c/STM-16 POS SPA LEDs](#), page 3-44
- [2-Port and 4-Port OC-48c/STM-16 POS SPA Interface Specifications](#), page 3-45
- [2-Port and 4-Port OC-48c/STM-16 POS SPA Cables, Optical Transceiver Modules, and Connectors](#), page 3-45

## 2-Port and 4-Port OC-48c/STM-16 POS SPA LEDs

The 2-Port and 4-Port OC-48c/STM-16 POS SPA has five types of LEDs: four LEDs for each port on the SPA, and one STATUS LED, as shown in [Figure 3-27](#).

**Figure 3-27** 2-Port OC-48c/STM-16 POS SPA Faceplate

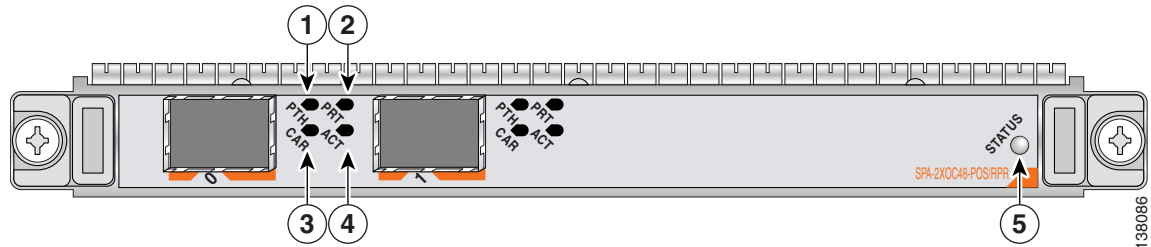

1	PTH (Pass Through) LED	4	ACT (Active Loopback) LED
2	PRT (Protect) LED	5	STATUS LED
3	CAR (Carrier Alarm) LED		

[Table 3-25](#) describes the 2-Port and 4-Port OC-48c/STM-16 POS SPA LEDs.

**Table 3-25** 2-Port and 4-Port OC-48c/STM-16 POS SPA LEDs

LED Label	Color	State	Meaning
PTH	Off	Off	Port is not in pass-through mode.
	Amber	On	Port is in pass-through mode.
CAR	Off	Off	Port is not enabled by software.
	Green	On	Port is enabled by software, and there is a valid SONET signal without any alarms.
	Amber	On	Port is enabled by software, and there is at least one alarm.
	Amber	Flashing	Port is enabled by software, and there is a side mismatch.
PRT	Off	Off	Port is not wrapped or steering.
	Green	On	A node on the ring is wrapped.
	Green	Flashing	A node on the ring is steering.
	Amber	On	Port is locally wrapped.
	Amber	Flashing	Port is locally steering.
ACT	Off	Off	Port is not enabled by software.
	Green	On	Port is enabled by software, and loopback is off.
	Amber	On	Port is enabled by software, and loopback is on.



**Table 3-25** 2-Port and 4-Port OC-48c/STM-16 POS SPA LEDs (continued)

LED Label	Color	State	Meaning
STATUS	Off	Off	SPA power is off.
	Green	On	SPA is ready and operational.
	Amber	On	SPA power is on and good, and the SPA is being configured.

## 2-Port and 4-Port OC-48c/STM-16 POS SPA Interface Specifications

The physical layer interface for the 2-Port and 4-Port OC-48c/STM-16 POS SPA is Optical Carrier-48 (OC-48), and provides SONET and SDH network connectivity with a per-port bandwidth of 2.488 Gbps.

## 2-Port and 4-Port OC-48c/STM-16 POS SPA Cables, Optical Transceiver Modules, and Connectors

Use single-mode (for intermediate-reach configurations) optical fiber cable to connect your router to a network or to connect two routers back-to-back.

The 2-Port and 4-Port OC-48c/STM-16 POS SPA supports the following types of optical transceiver modules:

- Single-mode short-reach (SR) SFP module—SFP-OC48-SR
- Single-mode intermediate-reach (IR) SFP module—SFP-OC48-IR1
- Single-mode long-reach (LR) SFP module—SFP-OC48-LR2

Each port on the 2-Port and 4-Port OC-48c/STM-16 POS SPA has one duplex LC-type receptacle. For single-mode optical fiber connections, you can use either a duplex LC-type cable (see [Figure 3-28](#)) or two simplex LC-type cables, one for transmit (TX) and one for receive (RX).

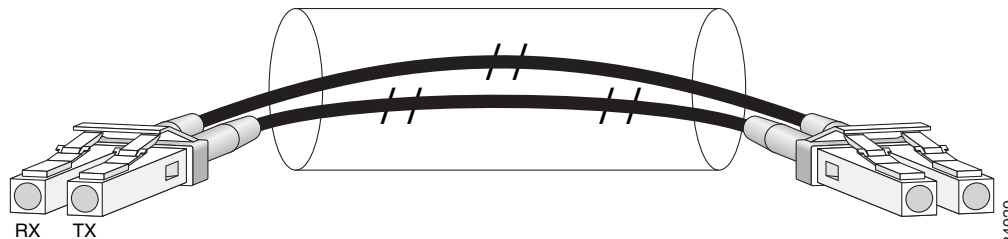
**Figure 3-28** LC-Type Cables

## OC-48 Module Connections

Table 3-26 describes the OC-48 specifications for use with the 2-Port and 4-Port OC-48c/STM-16 POS SPA.

**Table 3-26 OC-48 Specifications**

Specification	Description
Wavelength	OC-48 SR: 1266 nm to 1360 nm OC-48 IR-1: 1260 nm to 1360 nm OC-48 LR-2: 1500 nm to 1580 nm
Cabling distance (maximum)	OC-48 SR: 2 km (1.2 miles) OC-48 IR-1: 15 km (9.3 miles) OC-48 LR-2: 80 km (49.7 miles)
Operating case temperature range	OC-48 SR: 23 to 158°F (–5 to 70°C) OC-48 IR-1: 23 to 158°F (–5 to 70°C) OC-48 LR-2: 23 to 158°F (–5 to 70°C)
TX power	OC-48 SR: –10 to –3 dBm OC-48 IR-1: –5 to 0 dBm OC-48 LR-2: –2 to +3 dBm
Receiver sensitivity (maximum)	OC-48 SR: –18 dBm OC-48 IR-1: –18 dBm OC-48 LR-2: –28 dBm
RX overload	OC-48 SR: –3 dBm OC-48 IR-1: 0 dBm OC-48 LR-2: –9 dBm
Maximum receiver power damage	OC-48 SR: 5 dBm OC-48 IR-1: 5 dBm OC-48 LR-2: 5 dBm

## 1-Port OC-12c/STM-4 POS SPA Overview

The 1-Port OC-12c/STM-4 POS SPA is a single-height SPA and installs into one SIP subslot. The 1-Port OC-12c/STM-4 POS SPA with a small form-factor pluggable (SFP) optical transceiver module provides SONET and SDH network connectivity with a bandwidth of 622.08 Mbps.

For more information about SPAs and their compatibility with SIPs and modular optics, see the “[SIP and SPA Compatibility](#)” section on page 1-3.

The following sections describe the 1-Port OC-12c/STM-4 POS SPA:

- [1-Port OC-12c/STM-4 POS SPA LEDs](#), page 3-46
- [1-Port OC-12c/STM-4 POS SPA Interface Specifications](#), page 3-47
- [1-Port OC-12c/STM-4 POS SPA SFP Optical Transceiver Modules and Cables](#), page 3-48

## 1-Port OC-12c/STM-4 POS SPA LEDs

The 1-Port OC-12c/STM-4 POS SPA has three types of LEDs: two LEDs for each port on the SPA, and one STATUS LED, as shown in [Figure 3-29](#).

Figure 3-29 1-Port OC-12c/STM-4 POS SPA Faceplate

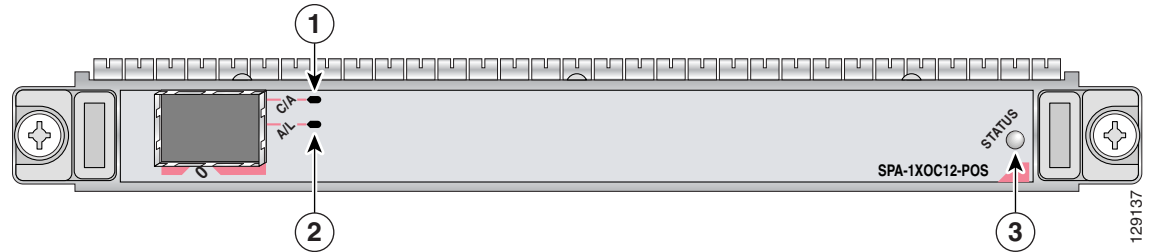

1	C/A (Carrier/Alarm) LED	3	STATUS LED
2	A/L (Active/Loopback) LED		

Table 3-27 describes the 1-Port OC-12c/STM-4 POS SPA LEDs.

Table 3-27 1-Port OC-12c/STM-4 POS SPA LEDs

LED Label	Color	State	Meaning
C/A	Off	Off	Port is not enabled by software.
	Green	On	Port is enabled by software, and there is a valid SONET signal without any alarms.
	Amber	On	Port is enabled by software, and there is at least one alarm.
A/L	Off	Off	Port is not enabled by software.
	Green	On	Port is enabled by software, and loopback is off.
	Amber	On	Port is enabled by software, and loopback is on.
STATUS	Off	Off	SPA power is off.
	Green	On	SPA is ready and operational.
	Amber	On	SPA power is on and good, and the SPA is being configured.

## 1-Port OC-12c/STM-4 POS SPA Interface Specifications

The framer processes incoming and outgoing SONET or SDH frames. The framer operates at OC-12c/STM-4 line rates (622.08 Mbps).

Packet data is transported with a user-configured encapsulation (such as Point-to-Point Protocol [PPP]), and is mapped into the STS-12c/STM-4 frame.

The 1-Port OC-12c/STM-4 POS SPA interface is compliant with the following RFCs:

- RFC 1619, *PPP over SONET/SDH*
- RFC 1662, *PPP in HDLC-like Framing*

The 1-Port OC-12c/STM-4 POS SPA also provides support for SNMP v1 agent (RFC 1155–1157) and RFC 1213:

- RFC 1155, *Structure and Identification of Management Information for TCP/IP-based Internets*
- RFC 1156, *Management Information Base for Network Management of TCP/IP-Based Internets*
- RFC 1157, *Simple Network Management Protocol (SNMP)*

- RFC 1213, *Management Information Base (MIB) for Network Management of TCP/IP-Based Internets: MIB II*

## 1-Port OC-12c/STM-4 POS SPA SFP Optical Transceiver Modules and Cables

The 1-Port OC-12c/STM-4 POS SPA uses a small form-factor pluggable (SFP) optical transceiver module installed in the port for SONET and SDH single-mode and multimode optical fiber connection (see [Figure 3-30](#)).

Cisco qualifies the optics that are approved for use with its SPAs. The 1-Port OC-12c/STM-4 POS SPA supports the following types of optical transceiver modules:

- Multimode (MM) SFP module—SFP-OC12-MM
- Short-reach (SR) SFP module—SFP-OC12-SR
- Intermediate-reach (IR) SFP module (15 km)—SFP-OC12-IR1
- Long-reach (LR) SFP module (40 km)—SFP-OC12-LR1
- Long-reach (LR) SFP module (80 km)—SFP-OC12-LR2

**Figure 3-30** SFP Optics Module

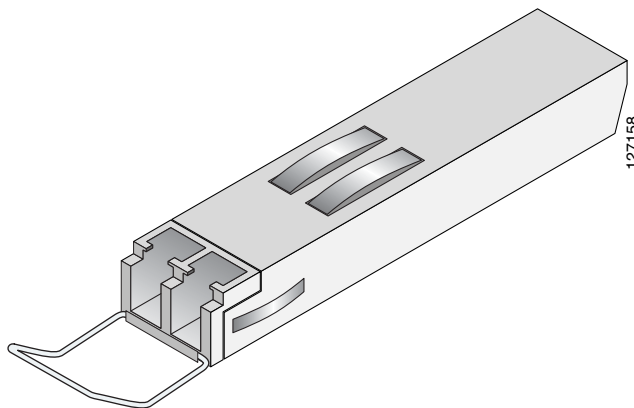

The SFP optical transceiver modules used with the 1-Port OC-12c/STM-4 POS SPA provide the following optical fiber options:

- Multimode—622.08-Mbps, OC-12 optical fiber (SONET STS-12c or SDH STM-4)  
Use a multimode optical fiber that has a core/cladding diameter of 62.5/125 microns.
- Single-mode—622.08-Mbps, OC-12 optical fiber (SONET STS-12c or SDH STM-4)  
Use a single-mode optical fiber that has a modal-field diameter of  $8.7 \pm 0.5$  microns. (Nominal diameter is approximately 10/125 microns.)

For single-mode and multimode optical fiber connections, you can use either a duplex LC-type cable (see [Figure 3-31](#)) or two simplex LC-type cables, one for transmit (TX) and one for receive (RX).

Use single-mode (for intermediate- or long-reach configurations) or multimode optical fiber cable to connect your router to a network or to connect two 1-Port OC-12c/STM-4 POS SPA-equipped routers back-to-back.

Long-range SFP optical transceiver modules (for long-reach configurations) cannot be connected back-to-back without using an attenuator between the two of them.

Figure 3-31 LC-Type Cables

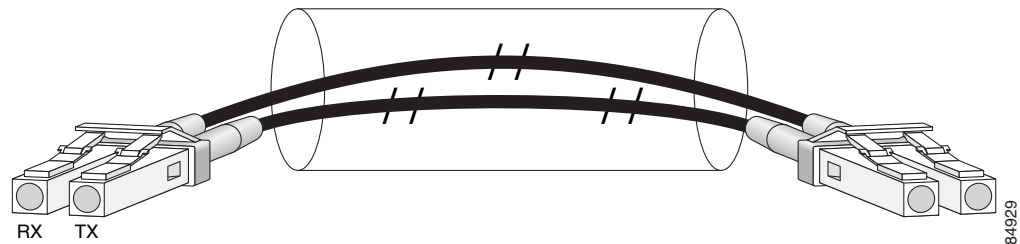

## 2-Port and 4-Port OC-12c/STM-1 POS SPA

### 2 port OC12 SPA (SPA-2XOC12-POS)

When one port is free to use; one license is required to use the remaining port.

License Request

Step1: Unshut Port0-No license is requested

Step2: Unshut Port1-One unit of license is required

License Released

Assuming all ports are in unshut state (One unit of license is already consumed)

Step1: Shut Port0-One license would be released (After this operation, Port1 is in unshut state and zero unit of license is consumed)

Device# show license summary

Smart Licensing is ENABLED

Registration:

Status: REGISTERED

Smart Account: XYZ\_1

Virtual Account: XYZ\_2

Export-Controlled Functionality: Allowed

Last Renewal Attempt: None

Next Renewal Attempt: Feb 19 14:01:25 2018 IST

License Authorization:

Status: AUTHORIZED

Last Communication Attempt: SUCCESS

Next Communication Attempt: Sep 22 14:01:32 2017 IST

License Usage:

License Entitlement tag Count Status

-----

ASR\_1000\_OC3-2-4 (ASR\_1000\_OC3-2-4) 1 AUTHORIZED

ASR\_1000\_OC12-1-2 (ASR\_1000\_OC12-1-2) 1 AUTHORIZED

## OC-12 Module Connections

Table 3-28 shows the OC-12 specifications of the optics on the 1-Port OC-12c/STM-4 POS SPA.

**Table 3-28** OC-12 Specifications

Specification	Description
Wavelength	OC-12 MM: 1270 nm to 1380 nm OC-12 SR: 1261 nm to 1360 nm OC-12 IR-1: 1293 nm to 1334 nm OC-12 LR-1: 1280 nm to 1335 nm OC-12 LR-2: 1480 nm to 1580 nm
Cabling distance (maximum)	OC-12 MM: 0.5 km (0.3 miles) OC-12 SR: 2 km (1.2 miles) OC-12 IR-1: 15 km (9.3 miles) OC-12 LR-1: 40 km (24.8 miles) OC-12 LR-2: 80 km (49.7 miles)
Operating case temperature range	OC-12 MM: 23 to 185°F (–5 to 85°C) OC-12 SR: 23 to 185°F (–5 to 85°C) OC-12 IR-1: 23 to 185°F (–5 to 85°C) OC-12 LR-1: 23 to 185°F (–5 to 85°C) OC-12 LR-2: 23 to 185°F (–5 to 85°C)
TX power	OC-12 MM: –20 to –14 dBm OC-12 SR: –15 to –8 dBm OC-12 IR-1: –15 to –8 dBm OC-12 LR-1: –3 to 2 dBm OC-12 LR-2: –3 to 2 dBm
Receiver sensitivity (maximum)	OC-12 MM: –26 dBm OC-12 SR: –23 dBm OC-12 IR-1: –28 dBm OC-12 LR-1: –28 dBm OC-12 LR-2: –28 dBm
RX overload	OC-12 MM: –6 dBm OC-12 SR: –8 dBm OC-12 IR-1: –8 dBm OC-12 LR-1: –8 dBm OC-12 LR-2: –8 dBm
Maximum receiver power damage	OC-12 MM: 5 dBm OC-12 SR: 5 dBm OC-12 IR-1: 5 dBm OC-12 LR-1: 5 dBm OC-12 LR-2: 5 dBm

## 2-Port, 4-Port, and 8-Port OC-12c/STM-4 POS SPA Overview

The 2-Port, 4-Port, and 8-Port OC-12c/STM-4 Multirate POS SPA is a single-height SPA that installs into one SIP subslot. For the OC-12 SPAs, any given channel can be configured as either OC-3 or OC-12, so the per-port bandwidth can be either 155.52 Mbps or 622.08 Mbps respectively, depending on the customer configuration.

**Note**

When SFP modules are replaced, the SPA interface retains any previously-defined configurations. These configurations include settings for IP address, clock source, loopback, CRC, and POS flags.

The 8-port OC-12c/STM-4 POS SPA is a full-rate SPA; therefore, it can only be installed in subslots 1 or 2 of the SIP. The 2-Port OC-12c/STM-4 POS and 4-Port OC-12c/STM-4 POS SPAs are half-rate SPAs.

The following sections describe the 2-Port, 4-Port, and 8-Port OC-12c/STM-4 Multirate POS SPA:

- [2-Port, 4-Port, and 8-Port OC-12c/STM-4 Multirate POS SPA LEDs](#), page 3-51
- [2-Port, 4-Port, and 8-Port OC-12c/STM-4 Multirate POS SPA Interface Specifications](#), page 3-52
- [2-Port, 4-Port, and 8-Port OC-12c/STM-4 Multirate POS SPA Optical Transceiver Modules, Connectors, and Cables](#), page 3-52

## 2-Port, 4-Port, and 8-Port OC-12c/STM-4 Multirate POS SPA LEDs

The 2-Port, 4-Port, and 8-Port OC-12c/STM-4 Multirate POS SPA has three LEDs: two LEDs for each port on the SPA, and one STATUS LED as shown in [Figure 3-32](#).

**Note**

Three different faceplates exist for the 2-Port, 4-Port, and 8-Port OC-12c/STM-4 Multirate POS SPAs. They each contain the same LEDs and the number of ports are 2, 4, and 8 respectively.

**Figure 3-32 8-Port OC-12c/STM-4 Multirate POS SPA Faceplate**

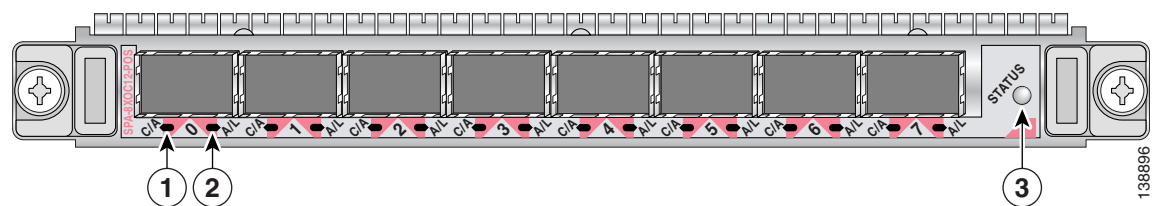

1	C/A (Carrier/Alarm) LED	3	STATUS LED
2	A/L (Active/Loopback) LED		

Table 3-29 describes the 2-Port, 4-Port, and 8-Port OC-12c/STM-4 Multirate POS SPA LEDs.

**Table 3-29 2-Port, 4-Port, and 8-Port OC-12c/STM-4 Multirate POS SPA LEDs**

LED Label	Color	State	Meaning
C/A	Off	Off	SONET controller is shut down.
	Green	On	Port is enabled by software, and there is a valid SONET signal without any alarms.
	Amber	On	Port is enabled by software, and there is at least one alarm.
A/L	Off	Off	Interface is shut down.
	Green	On	Port is enabled by software, and loopback is off.
	Amber	On	Port is enabled by software, and loopback is on.
STATUS	Off	Off	SPA power is off.
	Green	On	SPA is ready and operational.
	Amber	On	SPA power is on and good, and the SPA is being configured.

## 2-Port, 4-Port, and 8-Port OC-12c/STM-4 Multirate POS SPA Interface Specifications

The framer processes incoming and outgoing SONET frames. The framer operates at OC-12c/STM-4 line rates (622.08 Mbps).

Packet data is transported with a user-configured encapsulation (such as Point-to-Point Protocol [PPP]), and is mapped into the Layer 2 frame.

The 2-Port, 4-Port, and 8-Port OC-12c/STM-4 Multirate POS SPA interface complies with the following IETF RFCs:

- RFC 1662, *PPP in HDLC-like Framing*
- RFC 2427, *Multiprotocol Interconnect over Frame Relay Encapsulation*
- RFC 2615, *PPP over SONET/SDH*

## 2-Port, 4-Port, and 8-Port OC-12c/STM-4 Multirate POS SPA Optical Transceiver Modules, Connectors, and Cables

The 2-Port, 4-Port, and 8-Port OC-12c/STM-4 Multirate POS SPA uses a small form-factor pluggable (SFP) optical transceiver module installed in each port for SONET multimode optical fiber connection (see Figure 3-33).

The 2-Port, 4-Port, and 8-Port OC-12c/STM-4 Multirate POS SPA supports the following types of optical transceiver modules:

- Multimode (MM) SFP module—SFP-OC12-MM
- Short-reach (SR) SFP module—SFP-OC12-SR
- Intermediate-reach (IR) SFP module (15 km)—SFP-OC12-IR1
- Long-reach (LR) SFP module (40 km)—SFP-OC12-LR1



- Long-reach (LR) SFP module (80 km)—SFP-OC12-LR2

**Figure 3-33 SFP Optics Module**

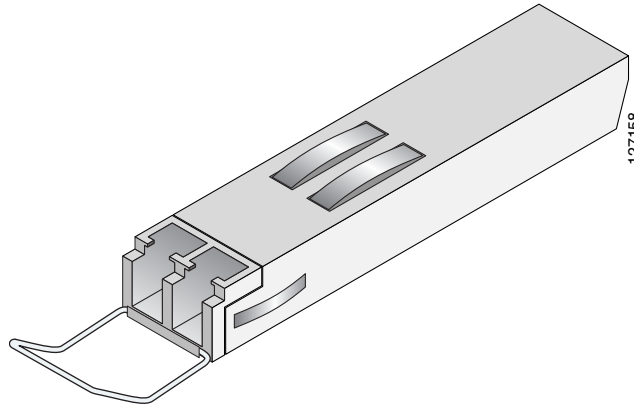

The SFP optical transceiver modules used with the 2-Port, 4-Port, and 8-Port OC-12c/STM-4 Multirate POS SPA provide the following optical fiber options:

- Multimode—622.08-Mbps, OC-12c/STM-4 optical fiber (SONET STS-12c or SDH STM-4)  
Use a multimode optical fiber that has a core/cladding diameter of 62.5/125 microns.
- Single-mode—622.08-Mbps, OC-12c/STM-4 optical fiber (SONET STS-12c or SDH STM-4)  
Use a single-mode optical fiber that has a modal-field diameter of  $8.7 \pm 0.5$  microns. (Nominal diameter is approximately 10/125 microns.)

For single-mode and multimode optical fiber connections, you can use either a duplex LC-type cable (see [Figure 3-34](#)) or two simplex LC-type cables, one for transmit (TX) and one for receive (RX).

Use single-mode (for short-, intermediate- or long-reach configurations) or multimode optical fiber cable to connect your router to a network or to connect two OC-3-equipped or OC-12-equipped routers back-to-back.

Long-range SFP optical transceiver modules (for long-reach configurations) cannot be connected back-to-back without using an attenuator between the two of them.

**Figure 3-34 LC -Type Cables**

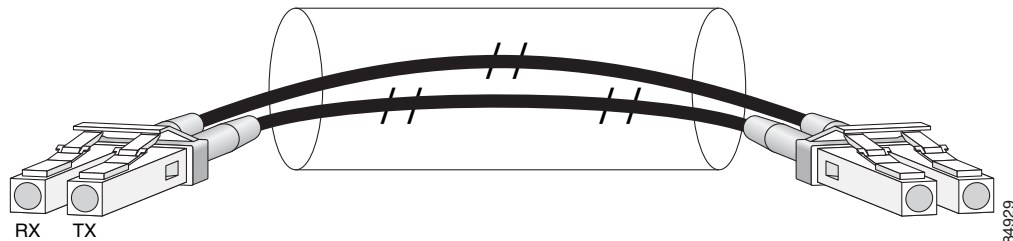

## OC-12 Module Connections

Table 3-30 shows the OC-12 specifications of the optics on the 2-Port, 4-Port, and 8-Port OC-12c/STM-4 Multirate POS SPA.

**Table 3-30 OC-12 Specifications**

Specification	Description
Wavelength	OC-12 MM: 1270 nm to 1380 nm OC-12 SR: 1261 nm to 1360 nm OC-12 IR-1: 1293 nm to 1334 nm OC-12 LR-1: 1280 nm to 1335 nm OC-12 LR-2: 1480 nm to 1580 nm
Cabling distance (maximum)	OC-12 MM: 0.5 km (0.3 miles) OC-12 SR: 2 km (1.2 miles) OC-12 IR-1: 15 km (9.3 miles) OC-12 LR-1: 40 km (24.8 miles) OC-12 LR-2: 80 km (49.7 miles)
Operating case temperature range	OC-12 MM: 23 to 185°F (–5 to 85°C) OC-12 SR: 23 to 185°F (–5 to 85°C) OC-12 IR-1: 23 to 185°F (–5 to 85°C) OC-12 LR-1: 23 to 185°F (–5 to 85°C) OC-12 LR-2: 23 to 185°F (–5 to 85°C)
TX power	OC-12 MM: –20 to –14 dBm OC-12 SR: –15 to –8 dBm OC-12 IR-1: –15 to –8 dBm OC-12 LR-1: –3 to 2 dBm OC-12 LR-2: –3 to 2 dBm
Receiver sensitivity (maximum)	OC-12 MM: –26 dB OC-12 SR: –23 dBm OC-12 IR-1: –28 dBm OC-12 LR-1: –28 dBm OC-12 LR-2: –28 dBm
RX overload	OC-12 MM: –6 dBm OC-12 SR: –8 dBm OC-12 IR-1: –8 dBm OC-12 LR-1: –8 dBm OC-12 LR-2: –8 dBm
Maximum receiver power damage	OC-12 MM: 5 dBm OC-12 SR: 5 dBm OC-12 IR-1: 5 dBm OC-12 LR-1: 5 dBm OC-12 LR-2: 5 dBm

## 1-Port OC-192c/STM-64 POS/RPR XFP SPA Overview

The 1-Port OC-192c/STM-64 POS/RPR XFP SPA is a single-height SPA that installs in one SIP subslot, and provides SONET and SDH network connectivity with a bandwidth of 9.95 Gbps.

The 1-Port OC-192c/STM-64 POS/RPR XFP SPA uses a 10-Gbps small form-factor pluggable (SFP) optical receptacle for each port allowing connection to single-mode optical fiber.

The following sections describe the 1-Port OC-192c/STM-64 POS/RPR XFP SPA:

- [1-Port OC-192c/STM-64 POS/RPR XFP SPA LEDs](#), page 3-55
- [1-Port OC-192c/STM-64 POS/RPR XFP SPA Interface Specifications](#), page 3-56
- [1-Port OC-192c/STM-64 POS/RPR XFP SPA Optical Transceiver Modules, Connectors, and Cables](#), page 3-56

## 1-Port OC-192c/STM-64 POS/RPR XFP SPA LEDs

The 1-Port OC-192c/STM-64 POS/RPR XFP SPA has six LEDs, as shown in [Figure 3-35](#).

**Figure 3-35** 1-Port OC-192c/STM-64 POS/RPR XFP SPA Faceplate

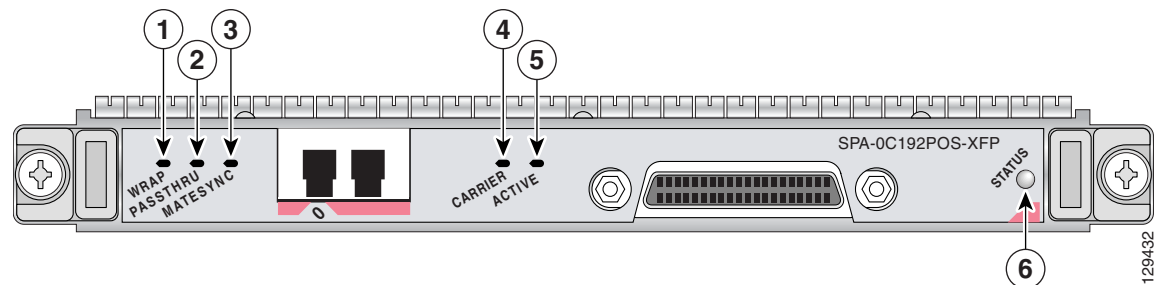

1	WRAP LED	4	CARRIER LED
2	PASSTHRU LED	5	ACTIVE LED
3	MATESYNC LED	6	STATUS LED

[Table 3-31](#) describes the 1-Port OC-192c/STM-64 POS/RPR XFP SPA LEDs.

**Table 3-31** 1-Port OC-192c/STM-64 POS/RPR XFP SPA LEDs

LED Label	Color	State	Meaning
WRAP	Off	Off	Port is not in wrap mode.
	Green	On	Port is in wrap mode somewhere on the ring.
	Amber	On	Port is in wrap mode locally.
PASSTHRU	Off	Off	Port is not in pass-through mode.
	Amber	On	Port is in pass-through mode.
MATESYNC	Off	Off	Mate port is not synchronized.
	Green	On	Mate port is synchronized.

**Table 3-31 1-Port OC-192c/STM-64 POS/RPR XFP SPA LEDs (continued)**

LED Label	Color	State	Meaning
CARRIER	Off	Off	Port is not enabled by software.
	Green	On	Port is enabled by software, and there is a valid SONET signal without any alarms.
	Amber	On	Port is enabled by software, and there is at least one alarm (LOS, LOF, RDI, and so on).
		Blinking	SRP mode mismatch alarm is indicated.
ACTIVE	Off	Off	Port is not enabled by software.
	Green	On	Port is enabled by software, and loopback is off.
	Amber	On	Port is enabled by software, and loopback is on.
STATUS	Off	Off	SPA power is off.
	Green	On	SPA is ready and operational.
	Amber	On	SPA power is on and good, and the SPA is being configured.

## 1-Port OC-192c/STM-64 POS/RPR XFP SPA Interface Specifications

The framer processes incoming and outgoing SONET or SDH frames. The framer operates at OC-192c/STM-64 line rates (9.95 Gbps).

Packet data is transported with a user-configured encapsulation (such as Point-to-Point Protocol [PPP]), and is mapped into the STS-192c/STM-64 frame.

The 1-Port OC-192c/STM-64 POS/RPR XFP SPA interface is compliant with the following RFCs:

- RFC 1662, *PPP in HDLC-like Framing*
- RFC 2615, *PPP over SONET/SDH*.

## 1-Port OC-192c/STM-64 POS/RPR XFP SPA Optical Transceiver Modules, Connectors, and Cables

The 1-Port OC-192c/STM-64 POS/RPR XFP SPA uses a single-mode, 9.95 Gbps, OC-192c optical fiber (SONET STS-192c or SDH STM-64) optical transceiver module for SONET and SDH connection to the network.

The 1-Port OC-192c/STM-64 POS/RPR XFP SPA supports the following types of optical transceiver modules:

- Single-mode short-reach (SR) XFP module—XFP-10GLR-OC192SR
- Single-mode intermediate-reach (IR) XFP module—XFP-10GER-OC192IR
- Single-mode very-long reach (LR) XFP module—XFP-10GZR-OC192LR

Cisco Systems qualifies the optics that are approved for use with its SPAs.

Use a single-mode optical fiber that has a modal-field diameter of  $8.7 \pm 0.5$  microns (nominal diameter is approximately 10/125 microns) to connect your router to a network.

Figure 3-36 shows the cable type for use with the XFP optical transceiver module on the 1-Port OC-192c/STM-64 POS/RPR XFP SPA.

**Figure 3-36 LC-Type Cable for the XFP Optical Transceiver Modules**

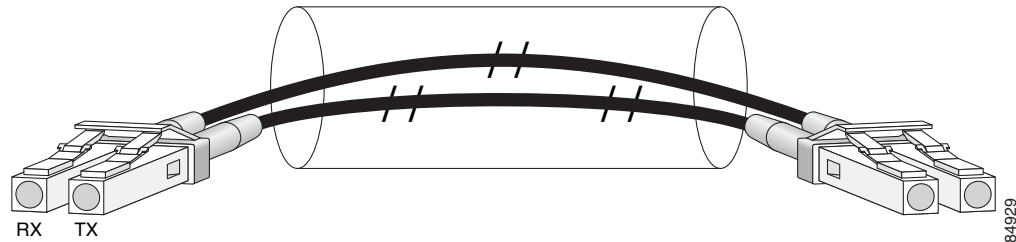

## OC-192 Module Connections

Table 3-32 shows the OC-192 specifications for use with the 1-Port OC-192c/STM-64 POS/RPR XFP SPA.

**Table 3-32 OC-192 Specifications**

Specification	Description
Wavelength	OC-192 SR-1: 1290 nm to 1330 nm OC-192 IR-2: 1530 nm to 1565 nm OC-192 LR-2: 1530 nm to 1565 nm
Cabling distance (maximum)	OC-192 SR-1: 2 km (1.2 miles) OC-192 IR-2: 40 km (24.8 miles) OC-192 LR-2: 50 miles (80 km)
Operating case temperature range	OC-192 SR-1: 23 to 158° F (–5 to 70° C) OC-192 IR-2: 23 to 158° F (–5 to 70° C) OC-192 LR-2: 23 to 158° F (–5 to 70° C)
Tx power	OC-192 SR-1: –6 dBm –1 dBm OC-192 IR-2: –1 dBm +2 dBm OC-192 LR-2: 0 to +4 dBm
Receiver sensitivity (maximum)	OC-192 SR-1: –11 dBm OC-192 IR-2: –14 dBm OC-192 LR-2: –24 dBm
RX overload	OC-192 SR-1: –1 dBm OC-192 IR-2: +2 dBm OC-192 LR-2: –7.0 dBm
Maximum receiver power damage	OC-192 SR-1: +5 dBm OC-192 IR-2: +5 dBm OC-192 LR-2: +5 dBm

## 2-Port, 4-Port, and 8-Port Clear-Channel T3/E3 Serial SPA Overview

The following sections describe the 2-Port, 4-Port, and 8-Port Clear-Channel T3/E3 SPA:

- [2-Port, 4-Port, and 8-Port Clear-Channel T3/E3 SPA LEDs](#), page 3-58
- [2-Port, 4-Port, and 8-Port Clear-Channel T3/E3 SPA Interface Specifications](#), page 3-59
- [2-Port, 4-Port, and 8-Port Clear-Channel T3/E3 SPA Cables and Connectors](#), page 3-59

### 2-Port, 4-Port, and 8-Port Clear-Channel T3/E3 SPA LEDs

The 2-Port, 4-Port, and 8-Port Clear-Channel T3/E3 SPA has three types of LEDs: two LEDs for each port on the SPA, and one STATUS LED, as shown in [Figure 3-37](#).

**Figure 3-37** 4-Port Clear-Channel T3/E3 Serial SPA Faceplate

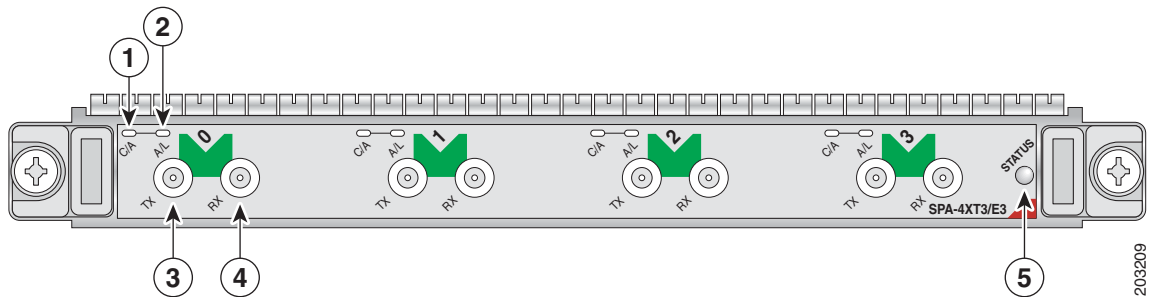

1	C/A (Carrier/Alarm) LED	4	RX (Receive) connector
2	A/L (Active/Loopback) LED	5	STATUS LED
3	TX (Transmit) connector		

Table 3-33 describes the 2-Port, 4-Port, and 8-Port Clear-Channel T3/E3 SPA LEDs.

**Table 3-33 2-Port, 4-Port, and 8-Port Clear-Channel T3/E3 SPA LEDs**

LED Label	Color	State	Meaning
C/A	Off	Off	Port is not enabled by software.
	Green	On	Port is enabled by software, and there is a valid E3 or T3 signal without any alarms.
	Amber	On	Port is enabled by software, and there is at least one alarm.
A/L	Off	Off	Port is not enabled by software.
	Green	On	Port is enabled by software, and loopback is off.
	Amber	On	Port is enabled by software, and loopback is on.
STATUS	Off	Off	SPA power is off.
	Green	On	SPA is ready and operational.
	Amber	On	SPA power is on and good, and the SPA is being configured.

## 2-Port, 4-Port, and 8-Port Clear-Channel T3/E3 SPA Interface Specifications

The framer processes incoming and outgoing T3 (cbit, m13/m23, and unframe) and E3 (g751, g832, and unframe) frames. The framer operates at T3/E3 line rates (44.736 Mbps/34.368 Mbps) depending on the mode in which it is configured.

Packet data is transported with a user-configurable encapsulation (such as Point-to-Point Protocol [PPP] or High-Level Data Link Control [HDLC]), and is mapped to T3 and E3 frames. The encapsulations add transport overhead to the packet of data frames before transporting, and are stripped when a packet is transported to the far end.

The T3/E3 SPA interface is compliant with ANSI and Telco standards. The interface also provides support for Management Information Base (MIB) RFC 2496 and T1.231.

## 2-Port, 4-Port, and 8-Port Clear-Channel T3/E3 SPA Cables and Connectors

The interface connectors on the 2-Port, 4-Port, and 8-Port Clear-Channel T3/E3 SPA are 75-ohm coaxial 1.0/2.3 cables that are specific to the T3/E3 SPA, with one connector and cable for transmit (TX) and one for receive (RX).

The following cables can be used with the 2-Port, 4-Port, and 8-Port Clear-Channel T3/E3 SPAs and any other T3/E3 SPAs:

- CAB-T3E3-DINBNC-F (T3 or E3 Cable, DINBNC female connector, 10 feet)
- CAB-T3E3-DINBNC-M (T3 or E3 Cable with DINBNC male connector, 10 feet)
- CAB-T3E3\_DINDIN-F (T3 or E3 Cable with DINDIN, female-female connectors, 10 feet)

The following cables can be used with the 2-Port and 4-Port Clear-Channel T3/E3 SPA and not with the 8-Port Clear-Channel T3/E3 Serial SPA. The cables have BNC connectors on one end and the 1.0/2.3 RF connectors on the other end.

- CAB-T3E3-RF-BNC-M (T3 or E3 Cable, 1.0/2.3 RF to mini BNC-Male, 10 feet)
- CAB-T3E3-RF-BNC-F (T3 or E3 Cable, 1.0/2.3 RF to mini BNC-Female, 10 feet)
- CAB-T3E3-RF-OPEN (T3 or E3 Cable, 1.0/2.3 RF to BNC-Open end, 10 feet)

**Note**

The Cisco cable part numbers are 72-4124-01 (with male BNC end) and 72-4131-01 (with female BNC end).

[Figure 3-37](#) shows the connectors on the 4-Port Clear-Channel T3/E3 Serial SPA, and [Table 3-34](#) describes the signal descriptions for these connectors.

**Table 3-34 2-Port, 4-Port, and 8-Port Clear-Channel T3/E3 SPA Connectors**

Connector Label	Meaning
TX	Transmitted signals appear on the center contact, and the outer shield is ground for the 75-ohm coaxial cable you attach to the TX DIN 1.0/2.3 connector.
RX	Received signals appear on the center contact, and the outer shield is ground for the 75-ohm coaxial cable you attach to the RX DIN 1.0/2.3 connector.

To mate and unmate the cable connector, follow these steps:

- To mate the 45-degree cable connector on to the 1.0/2.3 SPA connector, ensure the sliding barrel on the connector is pulled back and carefully slide or push the connector on to the mating part on the SPA board. Then, push the barrel forward.
- To unmate and remove the 45-degree cable connector, gently push the rear of the connector and simultaneously pull the sliding barrel of the connector towards you with your other hand. After the connector is unmated, you can remove the cable from the SPA.

## 2-Port and 4-Port Channelized T3 Serial SPA Overview

The following sections describe the 2-Port and 4-Port Channelized T3 SPA:

- [2-Port and 4-Port Channelized T3 SPA LEDs, page 3-61](#)
- [2-Port and 4-Port Channelized T3 SPA Interface Specifications, page 3-62](#)
- [2-Port and 4-Port Channelized T3 SPA Cables and Connectors, page 3-62](#)



## 2-Port and 4-Port Channelized T3 SPA LEDs

The 2-Port and 4-Port Channelized T3 SPA has three types of LEDs: two LEDs for each port on the SPA and one STATUS LED, as shown in [Figure 3-38](#).

**Figure 3-38** 4-Port Channelized T3 SPA Faceplate

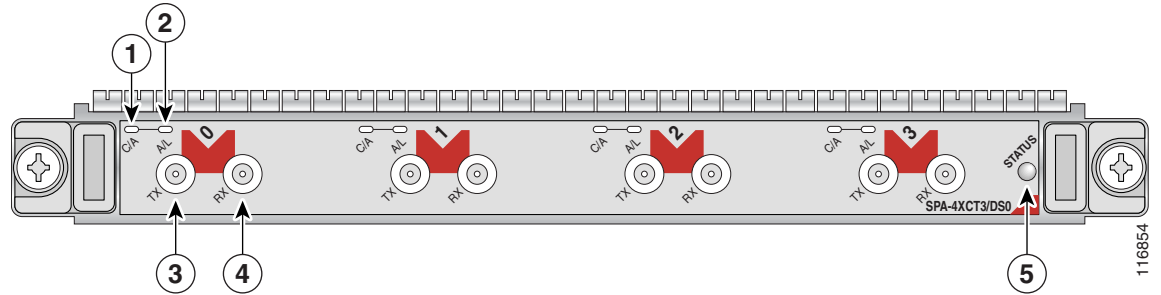

<b>1</b>	C/A (Carrier/Alarm) LED	<b>4</b>	RX (Receive) connector
<b>2</b>	A/L (Active/Loopback) LED	<b>5</b>	STATUS LED
<b>3</b>	TX (Transmit) connector		

Table 3-35 describes the 2-Port and 4-Port Channelized T3 SPA LEDs.

**Table 3-35 2-Port and 4-Port Channelized T3 SPA LEDs**

LED Label	Color	State	Meaning
C/A	Off	Off	Port is not enabled by software.
	Green	On	Port is enabled by software, and there is a valid T3 signal without any alarms.
	Amber	On	Port is enabled by software, and there is at least one alarm.
A/L	Off	Off	Port is not enabled by software.
	Green	On	Port is enabled by software, loopback is off.
	Amber	On	Port is enabled by software, loopback is on.
STATUS	Off	Off	SPA power is off.
	Green	On	SPA is ready and operational.
	Amber	On	SPA power is on and good, and SPA is being configured.

## 2-Port and 4-Port Channelized T3 SPA Interface Specifications

The framer processes incoming and outgoing T3 frames (cbit, m13/m23, and unframe). The framer operates at T3 line rates (44.2 Mbps).

Packet data is transported with a user-configurable encapsulation (such as Point-to-Point Protocol [PPP] or High-Level Data Link Control [HDLC]), and is mapped to T3 frames. The encapsulations add transport overhead to the packet of data frames before transporting, and are stripped when a packet is transported to the far end.

The T3 SPA interface is compliant with ANSI and Telco standards. The interface also provides support for Management Information Base (MIB) RFC 2495, RFC 2496, and T1.231.

## 2-Port and 4-Port Channelized T3 SPA Cables and Connectors

The interface connectors on the 2-Port and 4-Port Channelized T3 SPA are 75-ohm coaxial DIN 1.0/2.3 types, with one connector and cable for transmit (TX) and one for receive (RX).

The following cables can be used with the 2-Port and 4-Port Channelized T3 SPA. The cables have BNC connectors on one end and the DIN 1.0/2.3 connectors on the other.

- CAB-T3E3-RF-BNC-M (T3 or E3 Cable, 1.0/2.3 RF to mini BNC-Male, 10 feet)
- CAB-T3E3-RF-BNC-F (T3 or E3 Cable, 1.0/2.3 RF to mini BNC-Female, 10 feet)
- CAB-T3E3-RF-OPEN (T3 or E3 Cable, 1.0/2.3 RF to BNC-Open end, 10 feet)



### Note

The Cisco cable part numbers are 72-4124-01 (with Male BNC end) and 72-4131-01 (with Female BNC end).

Figure 3-38 shows the connectors on the 4-Port Channelized T3 SPA, and Table 3-36 provides the signal descriptions for these connectors.

**Table 3-36** 2-Port and 4-Port Channelized T3 SPA Connectors

Connector Label	Meaning
TX	Transmitted signals appear on the center contact, and the outer shield is ground for the 75-ohm coaxial cable you attach to the TX DIN 1.0/2.3 connector.
RX	Received signals appear on the center contact, and the outer shield is ground for the 75-ohm coaxial cable you attach to the RX DIN 1.0/2.3 connector.

## 4-Port Serial Interface SPA Overview

The following sections describe the 4-Port Serial Interface SPA:

- [4-Port Serial Interface SPA LEDs, page 3-63](#)
- [4-Port Serial Interface SPA Interface Specifications, page 3-64](#)
- [4-Port Serial Interface SPA Cables, Connectors, and Pinouts, page 3-65](#)

## 4-Port Serial Interface SPA LEDs

The 4-Port Serial Interface SPA has three types of LEDs: two LEDs for each port on the SPA, and one STATUS LED, as shown in Figure 3-39.

**Figure 3-39** 4-Port Serial Interface SPA Faceplate

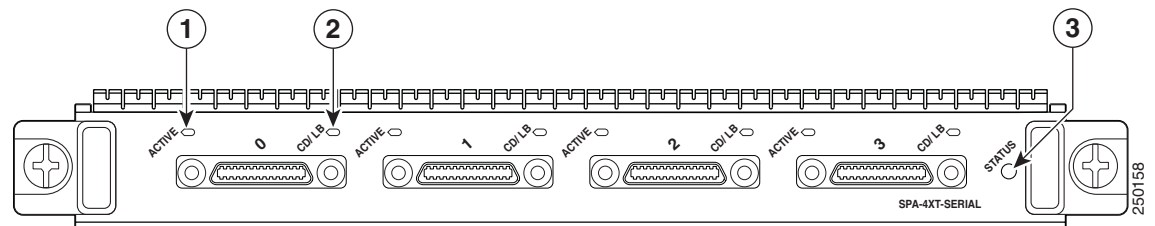

1	ACTIVE LED	3	STATUS LED
2	CD/LB (Carrier Detect/Loopback) LED		

Table 3-37 describes the 4-Port Serial Interface SPA LEDs.

**Table 3-37 4-Port Serial Interface LEDs**

LED Label	Color	State	Function
ACTIVE	Off	Off	The SPA port is not enabled by the field-programmable gate array (FPGA). The SPA port does not have any frame activity on RX/TX Layer 1.
	Green	Blinking	The SPA port is enabled by the FPGA, and it has Rx/Tx Layer 1 frame activity.
	Amber	On	This state is unused.
CD/LB	Off	Off	The SPA port is not enabled.
	Green	On	The SPA port is enabled, and DTR, DSR, RTS, CTS, or DCD is active.
	Amber	On	The SPA port is enabled, and local loopback or internal loopback is active.
STATUS	Off	Off	The SPA is powered off (power is not within required specification) or Status On conditions are not met.
	Green	On	The SPA is powered on and operational (power is within required specifications and initialization is complete). The following conditions must be met before the STATUS LED goes on: <ul style="list-style-type: none"> <li>• The SPA is correctly connected and receiving power.</li> <li>• The SPA-equipped card or router contains a valid microcode version that has been downloaded successfully.</li> <li>• The bus recognizes the SPA.</li> <li>• The SPA is up to date on the FPD versions required by the router software.</li> </ul>
	Amber	On	The SPA is powered on but initializing (power is within required specifications, but the hardware and software initialization sequence is not complete).

## 4-Port Serial Interface SPA Interface Specifications

The 4-Port Serial Interface SPA supports six interfaces in DCE and DTE mode:

- V.35
- EIA/TIA-232
- EIA/TIA-449

- EIA/TIA-530
- EIA/TIA-530A
- X.21

The 4-Port Serial Interface SPA provides up to four synchronous serial interfaces. Each port allows a maximum bandwidth of 8064 Kbps except for the X.21 and EIA/TIA-232 interfaces.

Use EIA/TIA-232 for speeds of 128 kilobits per second (kbps) and below. Use X.21 for speeds less than 2 Mbps. Use EIA/TIA-449, V.35, EIA/TIA-530, or EIA/TIA-530A for higher speeds.

## 4-Port Serial Interface SPA Cables, Connectors, and Pinouts

The 4-Port Serial Interface SPA uses Smart Serial cable interfaces that support two independent serial interface ports. The serial end of the Smart Serial cable is a 26-pin connector.

[Table 3-38](#) lists the 4-Port Serial Interface SPA cable interfaces.

**Table 3-38** 4-Port Serial Interface SPA Cables

Product Number	Cable Type	Length	Connector Type
CAB-SS-V35MT	V.35 DTE	10 feet (3 meters)	Male
CAB-SS-V35FC	V.35 DCE	10 feet (3 meters)	Female
CAB-SS-232MT	EIA/TIA-232 DTE	10 feet (3 meters)	Male
CAB-SS-232FC	EIA/TIA-232 DCE	10 feet (3 meters)	Female
CAB-SS-449MT	EIA/TIA-449 DTE	10 feet (3 meters)	Male
CAB-SS-449FC	EIA/TIA-449 DCE	10 feet (3 meters)	Female
CAB-SS-X21MT	X.21 DTE	10 feet (3 meters)	Male
CAB-SS-X21FC	X.21 DCE	10 feet (3 meters)	Female
CAB-SS-530MT	EIA/TIA-530 DTE	10 feet (3 meters)	Male
CAB-SS-530AMT	EIA/TIA-530A DTE	10 feet (3 meters)	Male

Figure 3-40 shows the Smart Serial cable connectors.

**Figure 3-40 Smart Serial Cable Connectors**

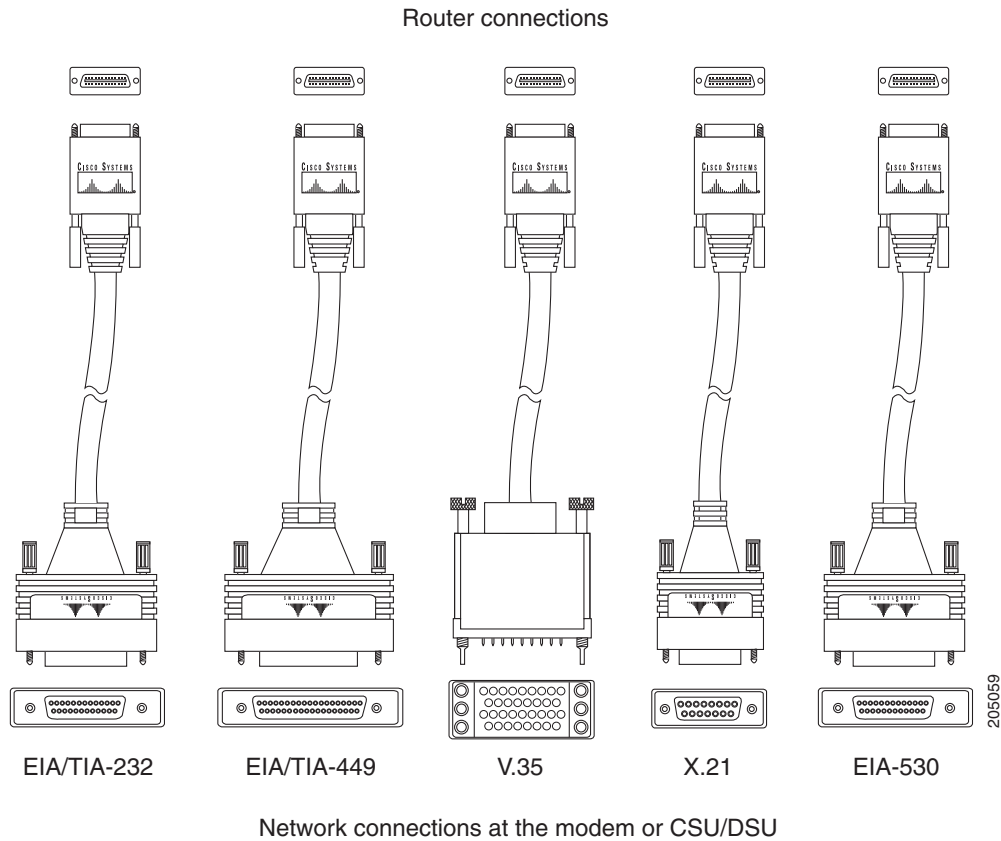

Table 3-39 lists the connector pinouts for the Smart Serial connectors that interface at the 4-Port Serial Interface SPA ports.

**Table 3-39 Smart Serial Connector Pinouts**

Pin	Signal	Pin	Signal
1	O_TXD/RXD+	14	O_TXD/RXD-
2	O_TXCE/RXC+	15	O_TXCE/RXC-
3	B_TXC/TXC+	16	B_TXC/TXC-
4	I_RXC/TXCE+	17	I_RXC/TXCE-
5	I_RXD/TXD+	18	I_RXD/TXD-
6	B_DCD/DCD+	19	B_DCD/DCD-
7	O_DTR/DSR+	20	O_DTR/DSR-
8	O_RTS/CTS+	21	MODE2
9	O_RTS/CTS-	22	MODE1
10	I_CTS/RTS-	23	MODE0
11	I_CTS/RTS+	24	MODEDCE

**Table 3-39 Smart Serial Connector Pinouts**

Pin	Signal	Pin	Signal
12	I_DSR/DTR+	25	I_DSR/DTR-
13	B_LL/LL+	26	GND

## 8-Port Channelized T1/E1 SPA Overview

The following sections describe the 8-Port Channelized T1/E1 Serial SPA:

- [8-Port Channelized T1/E1 Serial SPA LEDs](#), page 3-67
- [8-Port Channelized T1/E1 Serial SPA Interface Specifications](#), page 3-68
- [8-Port Channelized T1/E1 Serial SPA Cables, Connectors, and Pinouts](#), page 3-68

## 8-Port Channelized T1/E1 Serial SPA LEDs

The 8-Port Channelized T1/E1 Serial SPA has three types of LEDs: two LEDs for each port on the SPA, and one STATUS LED, as shown in [Figure 3-41](#).

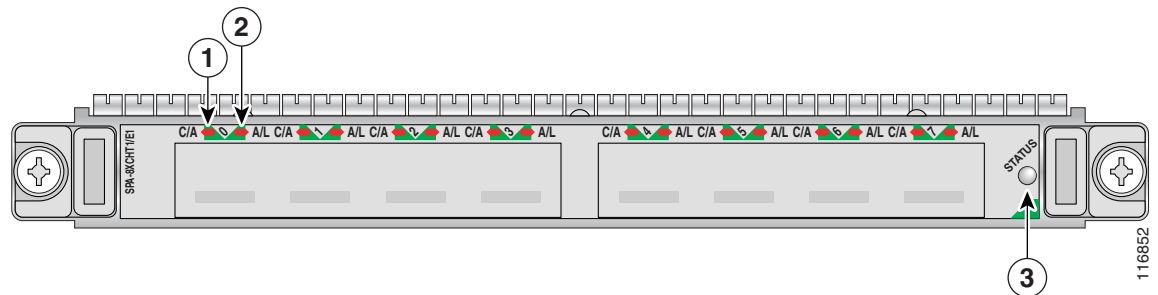
**Figure 3-41 8-Port Channelized T1/E1 Serial SPA Faceplate**

<b>1</b>	C/A (Carrier/Alarm) LED	<b>3</b>	STATUS LED
<b>2</b>	A/L (Active/Loopback) LED		

[Table 3-40](#) describes the 8-Port Channelized T1/E1 Serial SPA LEDs.

**Table 3-40 8-Port Channelized T1/E1 Serial SPA LEDs**

LED Label	Color	State	Meaning
C/A	Off	Off	Port is not enabled by software.
	Green	On	Port is enabled by software, and there is a valid T1 or E1 signal without any alarms.
	Amber	On	Port is enabled by software, and there is at least one alarm.

**Table 3-40** 8-Port Channelized T1/E1 Serial SPA LEDs

LED Label	Color	State	Meaning
A/L	Off	Off	Port is not enabled by software.
	Green	On	Port is enabled by software, loopback is off.
	Amber	On	Port is enabled by software, loopback is on.
STATUS	Off	Off	SPA power is off.
	Green	On	SPA is ready and operational.
	Amber	On	SPA power is on and good, and SPA is being configured.

## 8-Port Channelized T1/E1 Serial SPA Interface Specifications

The E1 interface on the 8-Port Channelized T1/E1 Serial SPA uses RJ-48c receptacles for E1 (120-ohm) cables with RJ-45 connectors. You can use all ports simultaneously. Each E1 connection supports interfaces that meet G.703 standards. The RJ-45 connection does not require an external transceiver. The E1 ports are E1 interfaces that use 120-ohm shielded twisted pair (STP) cables.

**Caution**

Shielded T1/E1 cables must be used to comply with FCC/EN55022/CISPR22 Class A emissions requirements.

## 8-Port Channelized T1/E1 Serial SPA Cables, Connectors, and Pinouts

Figure 3-42 shows an RJ-45 connector.

**Figure 3-42** RJ-45 Connector

Table 3-41 describes the signals and connector pinouts for RJ-45 cable connectors.

**Table 3-41** RJ-45 Connector Pinouts

Pin	Signal	Description
1	RX-	Receive ring -
2	RX+	Receive tip +
3	NC	No connection
4	TX-	Transmit ring -
5	TX+	Transmit tip +
6	NC	No connection

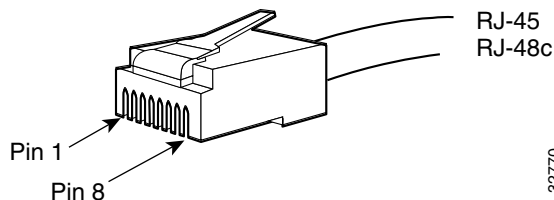

**Table 3-41 RJ-45 Connector Pinouts (continued)**

Pin	Signal	Description
7	NC	No connection
8	NC	No connection

## 1-Port Channelized STM-1/OC-3 SPA Overview

The following sections describe the 1-Port Channelized STM-1/OC-3 SPA:

- [1-Port Channelized STM-1/OC-3 SPA LEDs, page 3-70](#)
- [1-Port Channelized STM-1/OC-3 SPA Interface Specifications, page 3-70](#)
- [1-Port Channelized STM-1/OC-3 SPA Cables and Connectors, page 3-71](#)

## 1-Port Channelized STM-1/OC-3 SPA LEDs

The 1-Port Channelized STM-1/OC-3 SPA has three types of LEDs: a C/A LED, an A/L LED, and a STATUS LED, as shown in [Figure 3-43](#).

**Figure 3-43** 1-Port Channelized STM-1/OC-3 SPA Faceplate

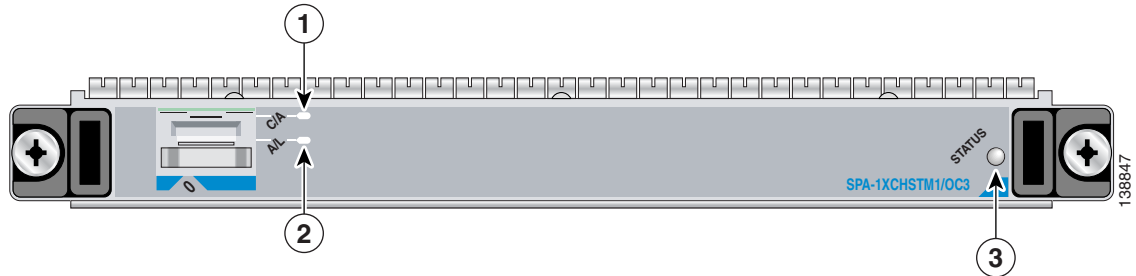

<b>1</b>	C/A (Carrier/Alarm) LED	<b>3</b>	STATUS LED
<b>2</b>	A/L (Active/Loopback) LED		

[Table 3-42](#) describes the 1-Port Channelized STM-1/OC-3 SPA LEDs.

**Table 3-42** 1-Port Channelized STM-1/OC-3 SPA LEDs

LED Label	Color	State	Meaning
C/A	Off	Off	Port is not enabled by software.
	Green	On	Port is enabled by software, and there is a valid T3 signal without any alarms.
	Amber	On	Port is enabled by software, and there is at least one alarm.
A/L	Off	Off	Port is not enabled by software.
	Green	On	Port is enabled by software, and loopback is off.
	Amber	On	Port is enabled by software, and loopback is on.
STATUS	Off	Off	SPA power is off.
	Green	On	SPA is ready and operational.
	Amber	On	SPA power is on and good, and SPA is being configured.

## 1-Port Channelized STM-1/OC-3 SPA Interface Specifications

The framer processes incoming and outgoing SONET or SDH frames. The framer operates at OC-3c/STM-1 line rates (155.52 Mbps).

Packet data is transported with a user-configured encapsulation (such as Point-to-Point Protocol [PPP]), and is mapped into the STS-3c/STM-1 frame.

The 1-Port Channelized STM-1/OC-3 SPA interface is compliant with RFC 1619, *PPP over SONET/SDH*, and RFC 1662, *PPP in HDLC-like Framing*. The 1-Port Channelized STM-1/OC-3 SPA also provides support for SNMP v1 agent (RFC 1155–1157), and Management Information Base (MIB) II (RFC 1213).

## 1-Port Channelized STM-1/OC-3 SPA Cables and Connectors

The 1-Port Channelized STM-1/OC-3 SPA uses a small form-factor pluggable (SFP) optical transceiver module installed in the port for SONET and SDH single-mode and multimode optical fiber connection (Figure 3-44).

**Figure 3-44** SFP Optics Module

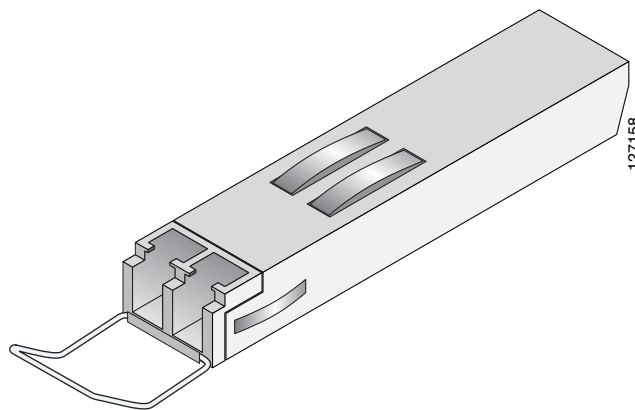

The SFP optical transceiver modules used with the 1-Port Channelized STM-1/OC-3 SPA provide the following optical fiber options:

- Multimode—155-Mbps, OC-3c/STM-1 optical fiber (SONET STS-3c or SDH STM-1)  
Use a multimode optical fiber that has a core or cladding diameter of 62.5/125 microns.
- Single-mode—155-Mbps, OC-3c/STM-1 optical fiber (SONET STS-3c or SDH STM-1)  
Use a single-mode optical fiber that has a modal-field diameter of  $8.7 \pm 0.5$  microns. (Nominal diameter is approximately 10/125 microns.)

For single-mode and multimode optical fiber connections, you can use either a duplex LC-type cable (see Figure 3-45) or two simplex LC-type cables, one for transmit (TX) and one for receive (RX).

Use single-mode (for intermediate- or long-reach configurations) or multimode optical fiber cable to connect your router to a network or to connect two 1-Port Channelized STM-1/OC-3 SPA-equipped routers back-to-back.

Long-range SFP optical transceiver modules (for long-reach configurations) cannot be connected back-to-back without using an attenuator between the two of them.

Figure 3-45 LC-Type Cables

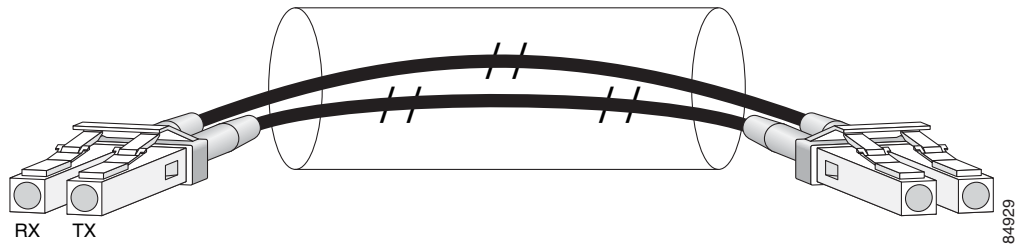

## 1-Port Channelized OC-12/STM-4 SPA Overview

The following sections describe the 1-Port Channelized OC-12/STM-4 SPA:

- [1-Port Channelized OC-12/STM-4 SPA LEDs, page 3-72](#)
- [1-Port Channelized OC-12/STM-4 SPA Interface Specifications, page 3-73](#)
- [1-Port Channelized OC-12/STM-4 SPA Cables and Connectors, page 3-73](#)

## 1-Port Channelized OC-12/STM-4 SPA LEDs

The 1-Port Channelized OC-12/STM-4 SPA has three types of LEDs: a C/A, A/L, and STATUS LED, as shown in [Figure 3-46](#).

Figure 3-46 1-Port Channelized OC-12/STM-4 SPA Faceplate

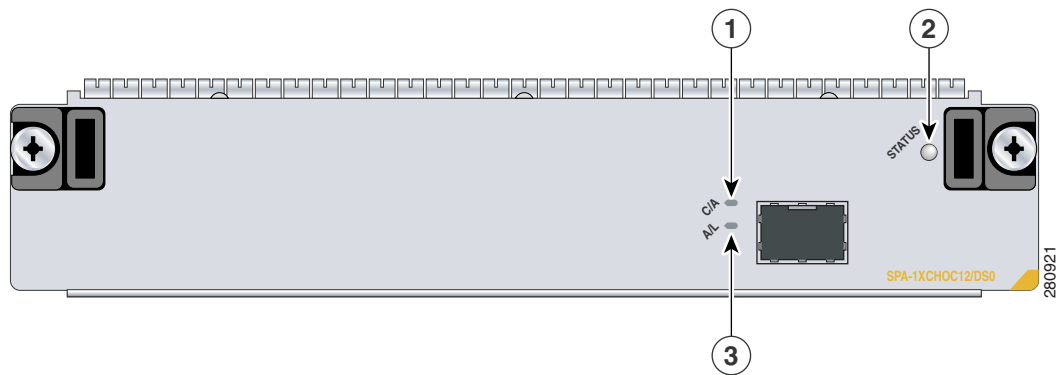

1	C/A (Carrier/Alarm) LED	3	STATUS LED
2	A/L (Active/Loopback) LED		

The 1-Port Channelized OC-12/STM-4 SPA LEDs are described in [Table 3-43](#).

**Table 3-43 1-Port Channelized OC-12/STM-4 SPA LEDs**

LED Label	Color	State	Meaning
C/A	Off	Off	Port is not enabled by software.
	Green	On	Port is enabled by software, and there is a valid signal without any alarms.
	Amber	On	Port is enabled by software, and there is at least one alarm.
A/L	Off	Off	Port is not enabled by software.
	Green	On	Port is enabled by software, loopback is off.
	Amber	On	Port is enabled by software, loopback is on.
STATUS	Off	Off	SPA power is off.
	Green	On	SPA is ready and operational.
	Amber	On	SPA power is on and good, and SPA is being configured.

## 1-Port Channelized OC-12/STM-4 SPA Interface Specifications

The framer processes incoming and outgoing SONET or SDH frames. The framer operates at OC-12/STM-4 line rates (622.08 Mbps), and supports channelization from OC-12 down to DS0 line rates.

Packet data is transported with a user-configured encapsulation (such as Point-to-Point Protocol [PPP]) and is mapped into the STS-12/STM-4 frame.

The 1-Port Channelized OC-12/STM-4 SPA interface is compliant with RFC 1619, *PPP over SONET/SDH*, and RFC 1662, *PPP in HDLC-like Framing*. The 1-Port Channelized OC-12/STM-4 SPA also provides support for SNMP v1 agent (RFC 1155–1157), and Management Information Base (MIB) II (RFC 1213).

## 1-Port Channelized OC-12/STM-4 SPA Cables and Connectors

The 1-Port Channelized OC-12/STM-4 SPA uses a small form-factor pluggable (SFP) optical transceiver module installed in each port for SONET and SDH single-mode and multimode optical fiber connection (see [Figure 3-47](#)).

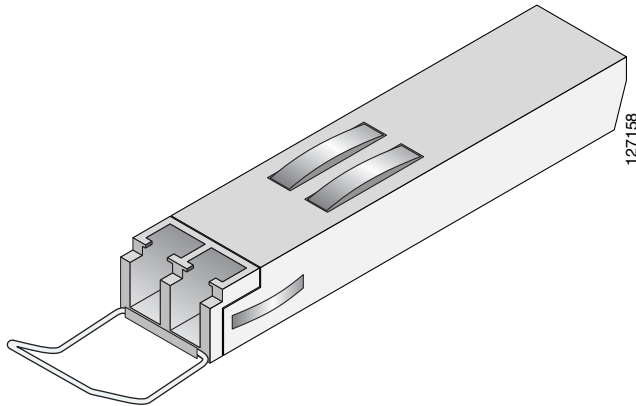
**Figure 3-47 SFP Optics Module**

The SFP optical transceiver modules used with the 1-Port Channelized OC-12/STM-4 SPA provide the following optical fiber options:

- Multimode—622-Mbps, OC-12/STM-4 optical fiber (SONET STS-12 or SDH STM-4)  
Use a multimode optical fiber that has a core/cladding diameter of 62.5/125 microns.
- Single-mode—622-Mbps, OC-12/STM-4 optical fiber (SONET STS-12 or SDH STM-4)  
Use a single-mode optical fiber that has a modal-field diameter of  $8.7 \pm 0.5$  microns. (Nominal diameter is approximately 10/125 microns.)

For single-mode and multimode optical fiber connections, you can use either a duplex LC-type cable (see [Figure 3-48](#)) or two simplex LC-type cables, one for transmit (TX) and one for receive (RX).

Use single-mode (for intermediate- or long-reach configurations) or multimode optical fiber cable to connect your router to a network or to connect two 1-Port Channelized OC-12/STM-4 SPA-equipped routers back to back.

Long-range SFP optical transceiver modules (for long-reach configurations) cannot be connected back-to-back without using an attenuator between the two of them.

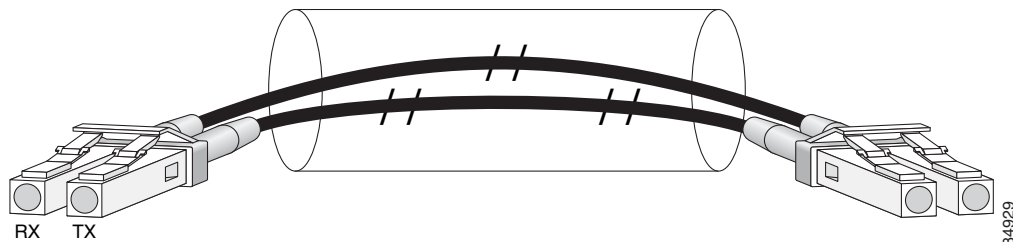
**Figure 3-48 LC Type Cables**

# Cisco WebEx Node for ASR 1000 Series Overview

The Cisco WebEx Node for Cisco ASR 1000 Series SPA (also referred to as the Cisco WebEx Node SPA) is a double-height SPA that improves the functionality of WebEx meeting services. The traffic between the enterprise network and the WebEx Data Center is decreased, greatly reducing Internet bandwidth requirements.

Each Cisco WebEx Node SPA can be configured to perform either web conferencing or voice and video conferencing but not both features on the same SPA. The Cisco WebEx Node SPA provides a virtual service engine interface (with a minimum bandwidth of 2.5 GB) to handle the TCP/IP traffic for all services running on the SPA.

## Cisco WebEx Node SPA LEDs

The Cisco WebEx Node SPA has three LEDs and one button, as shown in [Figure 3-49](#).



**Note**

The covered port on the faceplate near the STATUS LED is disabled and not intended for customer use.

**Figure 3-49 Cisco WebEx Node SPA Faceplate**

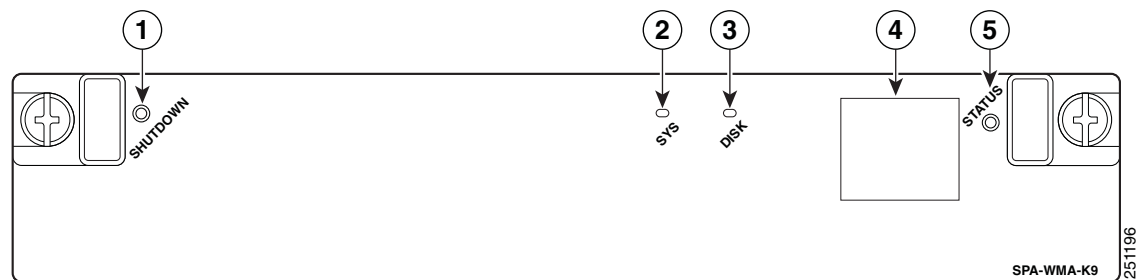

1	System shutdown button	4	Unused Ethernet port location
2	SYS LED	5	STATUS LED
3	DISK LED		



**Note**

Because the system shutdown button is recessed, you must use the tip of a pen or similar object to depress this button and initiate a shutdown of the SPA.

[Table 3-44](#) describes the Cisco WebEx Node SPA LEDs and Shutdown button.

**Table 3-44 Cisco WebEx Node SPA Front Shutdown Button and LEDs**

LED Label	Color	State	Meaning
Shutdown Button			A recessed button that can shut down the system. This is an alternate method to using the <b>shutdown</b> command.

**Table 3-44 Cisco WebEx Node SPA Front Shutdown Button and LEDs**

LED Label	Color	State	Meaning
SYS	Off	Off	System is shut down and ready for physical removal.
	Green	On	System is on and running.
	Green	Flashing	System shutdown is in progress.
DISK	Off	Off	Hard drive is inactive.
	Green	On	Hard drive is active.
STATUS	Off	Off	SPA power is off.
	Green	On	SPA is ready and operational.
	Amber	On	SPA power is on and good, and SPA is being configured.
		Blinking	SPA is undergoing FPD upgrade operation.

**Note**

Because the Cisco WebEx Node SPA is a services type of SPA, it does not support routable interfaces.

## Cisco DSP SPA for ASR 1000 Series Overview

To provide voice transcoding and transrating functionalities on Cisco ASR 1000 Series Routers, Cisco SPA-DSP (also referred to as SPA-DSP) has been introduced from Cisco IOS XE Release 3.2S. This section provides information about the need for a DSP SPA, and an overview of the SPA-DSP. It contains the following topics:

- [Understanding the Need for SPA-DSP, page 3-76](#)
- [SPA-DSP Overview, page 3-76](#)
- [SPA-DSP LED, page 3-78](#)

## Understanding the Need for SPA-DSP

The growth of Internet has increased not only in terms of transmitting data, but transmitting voice and video over Internet as well. Although the growth of Internet has been exponential, the implementation of the process to transmit voice and video is challenging. Voice is transmitted over internet using a specific codec from a pool of supported codecs. To provide decoding and encoding from one type of codec to another type, interoperability is needed. The SPA-DSP has been introduced mainly to provide voice transcoding and transrating capabilities.

## SPA-DSP Overview

The Cisco DSP SPA for Cisco ASR 1000 Series Routers is a half-height SPA that provides voice transcoding and transrating functionalities for media streams using different codecs. For example, translating a media stream that has been encoded using G.711 into G.729, it requires Digital Signal Processor (DSP). The SPA-DSP is a service SPA, and does not have any external physical interfaces. The SPA-DSP works in conjunction with the Session Border Controller (SBC) application to provide voice transcoding capabilities. The SPA-DSP can be installed in either SIP-10 or SIP-40 in any of the slots.



Each SPA-DSP comprises of seven SP2603 DSP chips having a total of 21 DSP cores (three DSP cores per SP2603). Based on the complexity of codec (low, medium, high), the density or maximum number of channels supported per DSP core and maximum channels supported per SPA-DSP are defined.

[Table 3-45](#) provides a matrix for the maximum number of channels supported on the DSP core and on SPA-DSP, and the complexity type:

**Table 3-45 Codec Complexity and Density Supported Matrix**

Codec Complexity or Service	Maximum Supported Density per DSP Core	Maximum Supported Density per SPA-DSP
LC (Low complexity) Voice/xcode	43	903
MC (Medium complexity) Voice/xcode	28	588
HC (High Complexity) Voice/xcode	17	357
ISAC Voice/xcode	8	168

[Table 3-46](#) provides hardware and software compatibility details for a SPA-DSP.

**Table 3-46 SPA-DSP Hardware and Software Compatibility**

Type of DSP SPA (Product ID)	ASR1000 Router Chassis Supported	Route Processor Supported	Power Requirements	SIPs Supported	ESPs Supported	Minimum Cisco IOS XE Release Supported
SPA-DSP	ASR 1002, ASR 1002-X, ASR 1004, and ASR 1006	RP1 and RP2	25 watts	SIP-10 and SIP-40	ESP-10 and ESP-40	Cisco IOS XE Release 3.2S

The SPA-DSP supports transcoding for the codecs listed in [Table 3-47](#).

**Table 3-47 SPA-DSP-Supported Transcoding Codec List**

Codec Name	Codec Description
g711alaw	G.711 A Law 64000 bps
g711ulaw	G.711 u Law 64000 bps
g722-64	G722r64
g723r53	G.723.1 5300 bps
g723r63	G.723.1 6300 bps
g726r16	G.726 16000 bps
g726r24	G.726 24000 bps
g726r32	G.726 32000 bps
g726r40	G.726 40000 bps

Codec Name	Codec Description
g728	G.728 codec
g729abr8	G.729ab 8000 bps
g729ar8	G.729a 8000 bps
g729br8	G.729b 8000 bps
g729r8	G.729 8000 bps
gsmamr-nb	GSMAMR codec
ilbc	ILBC codec
isac	ISAC codec
pass-through	Stream Pass Through

## Features of SPA-DSP

Following are the features of SPA-DSP:

- Enhances ASR 1000 Series Router capabilities by providing DSP-based voice transcoding and transrating solutions.
- Translates one type of media stream (voice) to another type of media stream that uses different media encoding and decoding technologies.
- Enables translation between different packetization settings and provides dual tone multifrequency (DTMF) interworking.
- Provisions the configuration of SBC as either a Unified SBC or Distributed SBC with on-board DSPs or with a centralized DSP providing transcoding for multiple SBCs.
- Faceplates LEDs to indicate SPA status.
- Monitors voltage and temperature.
- Supports online insertion and removal (OIR).

## SPA-DSP LED

SPA-DSPs have only one type of LED, which is the STATUS LED type, as shown in [Figure 3-50](#).

**Figure 3-50** SPA-DSP Faceplate

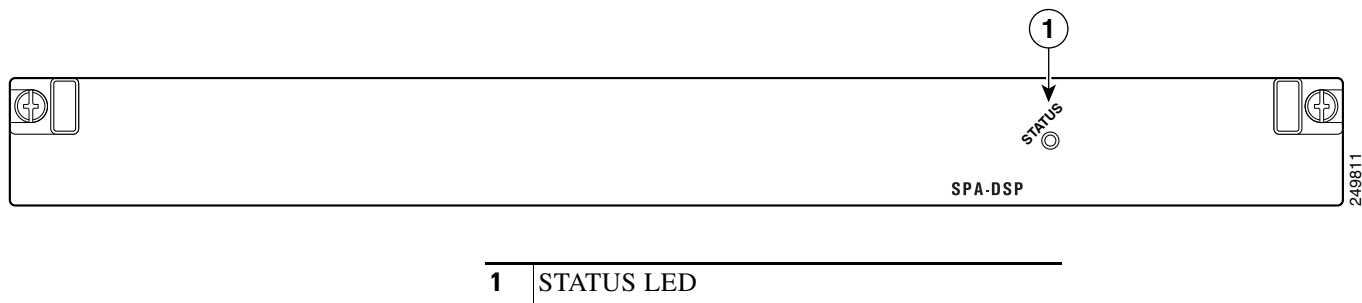

[Table 3-48](#) describes the SPA-DSP LED.

**Table 3-48 SPA-DSP LED**

LED Label	Color	State	Meaning
STATUS	No color	Off	SPA power is off.
	Amber	On	SPA power is on and the SPA is being configured.
	Green	On	SPA is ready and operational.

## 1-Port Channelized OC3 STM-1 ATM CEoP SPA Overview

The following sections describe the 1-Port Channelized OC-3 ATM CEoP SPA:

- [1-Port Channelized OC-3 ATM CEoP SPA LEDs](#)
- [1-Port Channelized OC-3 ATM CEoP SPA Interface Specifications](#)
- [1-Port Channelized OC-3 ATM CEoP SPA Optical Transceiver Modules and Cables](#)

### 1-Port Channelized OC-3 ATM CEoP SPA LEDs

The 1-Port Channelized OC-3 ATM CEoP SPA has three LEDs, two for the port on the SPA, and one STATUS LED, as shown in the following figure.

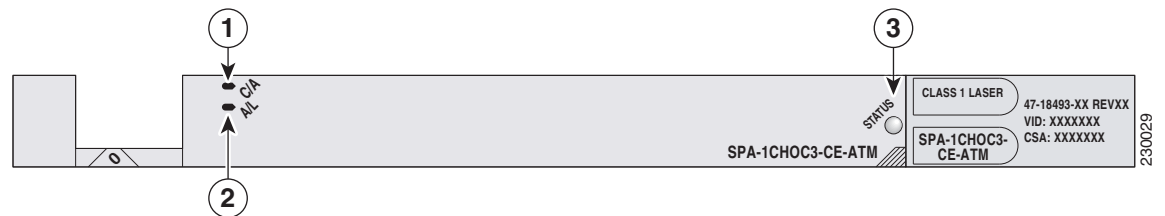
**Figure 3-51 1-Port Channelized OC-3 ATM CEoP SPA Faceplate**

<b>1</b>	C/A (Carrier/Alarm) LED	<b>3</b>	STATUS LED
<b>2</b>	A/L (Active/Loopback) LED		

Table 3-49 describes the 1-Port Channelized OC-3 ATM CEoP SPA LEDs.

**Table 3-49 1-Port Channelized OC-3 ATM CEoP SPA LEDs**

LED Label	Color	State	Meaning
C/A	Off	Off	Port is not enabled by software.
	Green	On	Port is enabled by software.
	Amber	On	Port is enabled by software, and there is at least one alarm.
A/L	Off	Off	Port is not enabled by software.
	Green	On	Port is enabled by software, loopback is off.
	Amber	On	Port is enabled by software, loopback is on.
STATUS	Off	Off	SPA power is off.
	Amber	On	SPA power is on and good, and SPA is being configured.
	Green	On	SPA is ready and operational.

## 1-Port Channelized OC-3 ATM CEoP SPA Interface Specifications

The physical layer interface for the 1-Port Channelized OC-3 ATM CEoP SPA is Optical Carrier-3 (OC-3). The total bandwidth for the SPA is 155.52 Mbps. The 1-Port Channelized OC-3 ATM CEoP SPA can be channelized to either a maximum of 84 T1s or a maximum of 63 E1s.



### Note

The 1-Port Channelized OC-3 ATM CEoP SPA can be channelized to E1s, only when SDH framing mode is used. Channelization to T1s is possible both in SONET and SDH framing mode.

The single SPA port accepts an SFP module with a duplex LC-type receptacle that allows connection to optical fiber.

## 1-Port Channelized OC-3 ATM CEoP SPA Optical Transceiver Modules and Cables

Cisco Systems, Inc. qualifies the optics that are approved for use with its SPAs. The 1-Port Channelized OC-3 ATM CEoP SPA supports the following types of optical transceiver modules:

- Multimode (MM) SFP module (500m)—SFP-OC3-MM
- Short-Reach (SR) SFP module (2 km)—SFP-OC3-SR
- Intermediate-Reach (IR) SFP module (15 km)—SFP-OC3-IR1
- Long-Reach (LR) SFP module (40 km)—SFP-OC3-LR1
- Long-Reach 2 (LR2) or Extended Reach SFP module (80 km)—SFP-OC3-LR2

## 2-Port Channelized T3/E3 ATM CEoP SPA Overview

The following sections describe the 2-Port Channelized T3/E3 ATM CEoP SPA:

- [2-Port Channelized T3/E3 ATM CEoP SPA LEDs](#)
- [2-Port Channelized T3/E3 ATM CEoP SPA Interface Specifications](#)
- [2-Port Channelized T3/E3 ATM CEoP SPA Cables and Connectors](#)

### 2-Port Channelized T3/E3 ATM CEoP SPA LEDs

The 2-Port Channelized T3/E3 ATM CEoP SPA has three types of LEDs (see [Figure 3-52](#)). There are two LEDs for each port on the SPA, and a single STATUS LED for the SPA.

**Figure 3-52** 2-Port Channelized T3/E3 ATM CEoP SPA Faceplate

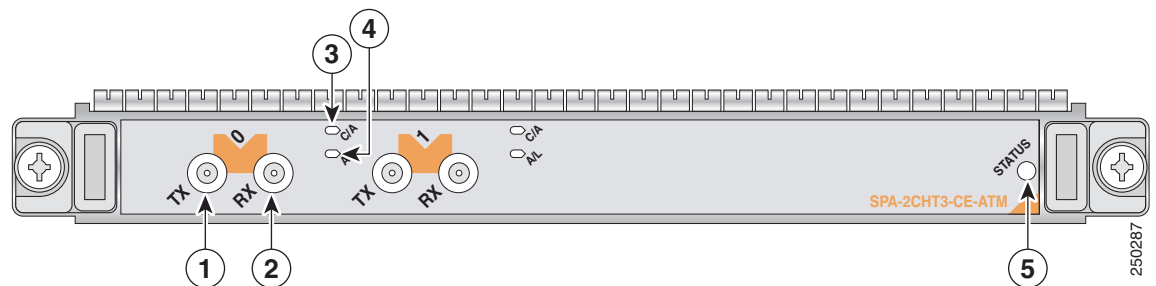

<b>1</b>	TX (Transmit) connector	<b>4</b>	A/L (Active/Loopback)
<b>2</b>	RX (Receive) connector	<b>5</b>	STATUS LED
<b>3</b>	C/A (Carrier/Alarm) LED		

The 2-Port Channelized T3/E3 ATM CEoP SPA LEDs are described in [Table 3-50](#).

**Table 3-50** 2-Port Channelized T3/E3 ATM CEoP SPA LEDs

LED Label	Color	State	Meaning
C/A	Off	Off	Port is not enabled by software.
	Green	On	Port is enabled by software.
	Amber	On	Port is enabled by software and there is at least one alarm.
A/L	Off	Off	Port is not enabled by software.
	Green	On	Port is enabled by software, loopback is off.
	Amber	On	Port is enabled by software, loopback is on.
STATUS	Off	Off	SPA power is off.
	Amber	On	SPA power is on and the SPA is being configured.
	Green	On	SPA is ready and operational.

## 2-Port Channelized T3/E3 ATM CEoP SPA Interface Specifications

The framer processes the incoming and outgoing T3 (C-Bit, m13/m23, and unframe) and E3 (g751) frames. The framer operates at T3 or E3 line rates (44.736 or 34.368 Mbps), depending on the mode in which it is configured.

**Note**

Effective from Cisco IOS XE Release 3.4.0S, the 2-Port Channelized T3/E3 ATM CEoP SPA supports only the ATM mode and not the CEM mode. It supports ATM only on the clear-channel T3 mode.

**Note**

Effective from Cisco IOS XE Release 3.5.0S, the SPA-2CHT3-CE-ATM supports ATM on the clear-channel E3 mode.

The T3 or E3 data is encapsulated and sent across the MPLS network over user-configurable pseudowires. In the ATM, the data is encapsulated into ATM cells and transported across the network.

The T3/E3 SPA interface is compliant with ANSI and Telco standards. The interface also provides support for Management Information Base (MIB) RFC 2495, RFC 2496, and T1.231.

**Note**

Effective from Cisco IOS XE Release 3.6.0S, the SPA-2CHT3-CE-ATM supports the CEM mode.

## 2-Port Channelized T3/E3 ATM CEoP SPA Cables and Connectors

The interface connectors on the 2-Port Channelized T3/E3 ATM CEoP SPA are 75-ohm coaxial DIN 1.0/2.3 types, with one connector and cable for transmit (TX) and one for receive (RX).

The following cables can be used with the 2-Port Channelized T3/E3 ATM CEoP SPA. The cables have BNC connectors on one end and DIN 1.0/2.3 connectors on the other end. If similar SPAs are connected back-to-back, both ends of the cable are DIN 1.0/2.3.

The cables specifications that can be used for the 2-Port Channelized T3/E3 ATM CEoP SPA are:

- CAB-T3E3-RF-BNC-M (T3 or E3 Cable, 1.0/2.3 RF to mini BNC-Male, 10 feet)
- CAB-T3E3-RF-BNC-F (T3 or E3 Cable, 1.0/2.3 RF to mini BNC-Female, 10 feet)
- CAB-T3E3-RF-OPEN (T3 or E3 Cable, 1.0/2.3 RF to BNC-Open end, 10 feet)

**Note**

The Cisco cable part numbers are 72-4124-01 (for the male BNC end) and 72-4131-01 (for the female BNC end). A SPA can receive data over the cable up to a maximum distance of 1350 ft (411.5 meters).

Table 3-51 describes the signal descriptions for the 2-Port Channelized T3/E3 ATM CCoP SPA connectors shown in Figure 3-52.

**Table 3-51 2-Port Channelized T3/E3 ATM CCoP SPA Connectors**

Connector Label	Meaning
TX	Transmitted signals appear on the center contact. The outer shield is ground for the 75-ohm coaxial cable you attach to the TX DIN 1.0/2.3 connector.
RX	Received signals appear on the center contact. The outer shield is ground for the 75-ohm coaxial cable you attach to the RX DIN 1.0/2.3 connector.

## 24-Port Channelized T1/E1/J1 ATM CCoP SPA Overview

The following sections describe the 24-Port Channelized T1/E1/J1 CCoP SPA:

- [24-Port Channelized T1/E1/J1 CCoP SPA LEDs](#)
- [24-Port Channelized T1/E1/J1 CCoP SPA Interface Specifications](#)
- [24-Port Channelized T1/E1/J1 CCoP SPA Cables and Connectors](#)
- [24-Port Channelized T1/E1/J1 CCoP SPA Patch Panel](#)

## 24-Port Channelized T1/E1/J1 CCoP SPA LEDs

The 24-Port Channelized T1/E1/J1 CCoP SPA has two types of LEDs, as shown in the following figure:

**Figure 3-53 24-Port Channelized T1/E1/J1 CCoP SPA Faceplate**

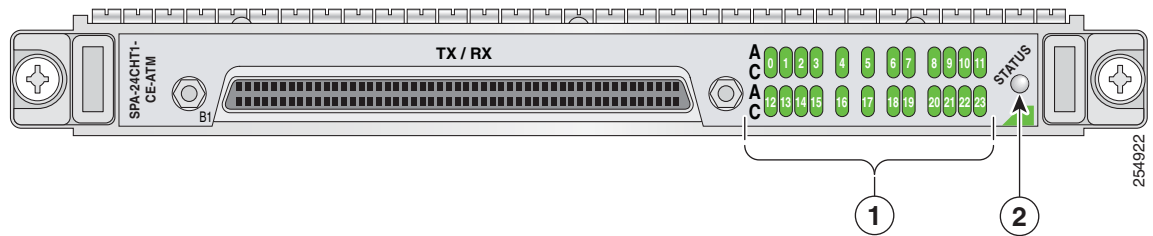

<b>1</b>	A/C (Alarm/Carrier) LEDs	<b>2</b>	STATUS LED
----------	--------------------------	----------	------------

Table 3-49 describes the 24-Port Channelized T1/E1/J1 CEoP SPA LEDs.

**Table 3-52 24-Port Channelized T1/E1 ATM CEoP SPA LEDs**

LED Label	Color	State	Meaning
STATUS	Off	Off	SPA power is off.
	Amber	On	SPA power is on and good, and SPA is being configured.
	Green	On	SPA is ready and operational.
A/C	Off	Off	Port is not enabled by software.
	Green	On	Port is enabled by software.
	Amber	On	Port is enabled by software, and there is at least one alarm.

## 24-Port Channelized T1/E1/J1 CEoP SPA Interface Specifications

The physical layer interface for the 24-Port Channelized T1/E1/J1 CEoP SPA is a customer-installed high-density connector. This connector has thumbscrews that should be screwed into the SPA when the cable is installed.

## 24-Port Channelized T1/E1/J1 CEoP SPA Cables and Connectors

The 24-Port Channelized T1/E1/J1 CEoP SPA requires a Cisco cable (part number CABLE-24T1E1J1), which is shown in Figure 3-54.

**Figure 3-54 24-Port Channelized T1/E1/J1 CEoP SPA High-Density Cable**

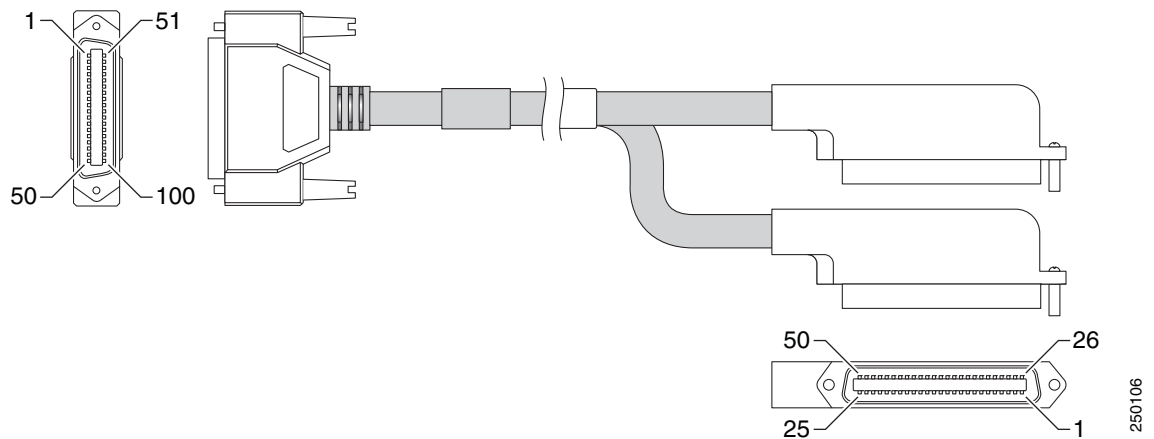



## Cable Installation

One end of the cable has a 100-pin connector that plugs into the front of the 24-Port Channelized T1/E1/J1 CEoP SPA. Use the thumbscrews on either side of the connector to secure the cable to the SPA.

The other end of the cable has two 50-pin Telco connectors that can be attached to the rear of a 24-port RJ-45 patch panel. Both connectors are identical: one is for Transmit (TX) and the other is for Receive (RX). [Figure 3-55](#) shows how the cable is connected between the 24-Port Channelized T1/E1/J1 CEoP SPA and the patch panel.

**Figure 3-55** Cable Installation Between the SPA and the Patch Panel

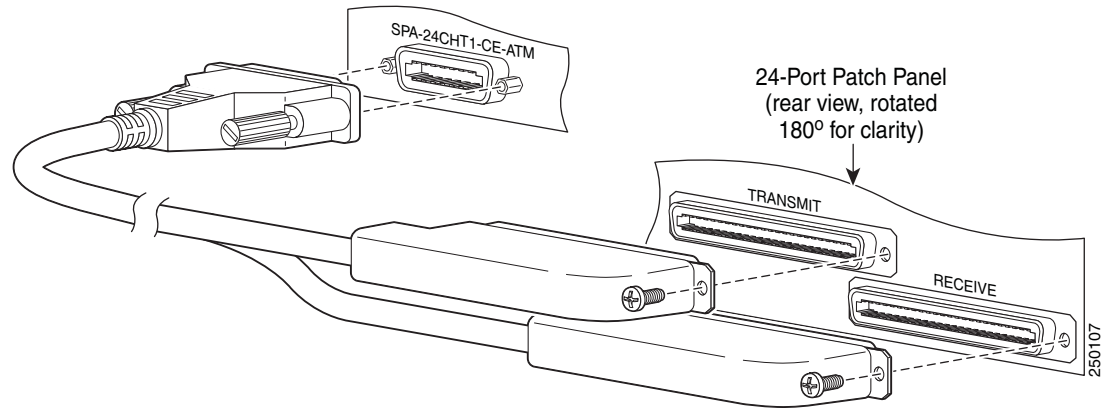

## SPA Cable Pinouts

[Table 3-53](#) shows the cable pinouts for the cable (part number CABLE-24T1E1J1) that is installed between the 24-Port Channelized T1/E1/J1 CEoP SPA and the rear of the patch panel.

**Table 3-53** 24-Port Channelized T1/E1 ATM CEoP SPA Cable Connector Pinouts

Subscriber		Connector Pins		
Line	Signal	SPA	TX Cable Lead	RX Cable Lead
Line 1	TX Tip	2	1	Not connected
	TX Ring	52	26	
	RX Tip	26	Not connected	1
	RX Ring	76		26
Line 2	TX Tip	3	2	Not connected
	TX Ring	53	27	
	RX Tip	27	Not connected	2
	RX Ring	77		27
Line 3	TX Tip	4	3	Not connected
	TX Ring	54	28	
	RX Tip	28	Not connected	3
	RX Ring	78		28

**Table 3-53 24-Port Channelized T1/E1 ATM CEoP SPA Cable Connector Pinouts (continued)**

Subscriber		Connector Pins		
Line	Signal	SPA	TX Cable Lead	RX Cable Lead
Line 4	TX Tip	5	4	Not connected
	TX Ring	55	29	
	RX Tip	29	Not connected	4
	RX Ring	79		29
Line 5	TX Tip	6	5	Not connected
	TX Ring	56	30	
	RX Tip	30	Not connected	5
	RX Ring	80		30
Line 6	TX Tip	7	6	Not connected
	TX Ring	57	31	
	RX Tip	31	Not connected	6
	RX Ring	81		31
Line 7	TX Tip	8	7	Not connected
	TX Ring	58	32	
	RX Tip	32	Not connected	7
	RX Ring	82		32
Line 8	TX Tip	9	8	Not connected
	TX Ring	59	33	
	RX Tip	33	Not connected	8
	RX Ring	83		33
Line 9	TX Tip	10	9	Not connected
	TX Ring	60	34	
	RX Tip	34	Not connected	9
	RX Ring	84		34
Line 10	TX Tip	11	10	Not connected
	TX Ring	61	35	
	RX Tip	35	Not connected	10
	RX Ring	85		35
Line 11	TX Tip	12	11	Not connected
	TX Ring	62	36	
	RX Tip	36	Not connected	11
	RX Ring	86		36
Line 12	TX Tip	13	12	Not connected
	TX Ring	63	37	
	RX Tip	37	Not connected	12
	RX Ring	87		37
Line 13	TX Tip	14	13	Not connected
	TX Ring	64	38	
	RX Tip	38	Not connected	13
	RX Ring	88		38

**Table 3-53 24-Port Channelized T1/E1 ATM CCoP SPA Cable Connector Pinouts (continued)**

Subscriber		Connector Pins		
Line	Signal	SPA	TX Cable Lead	RX Cable Lead
Line 14	TX Tip	15	14	Not connected
	TX Ring	65	39	
	RX Tip	39	Not connected	14
	RX Ring	89		39
Line 15	TX Tip	16	15	Not connected
	TX Ring	66	40	
	RX Tip	40	Not connected	15
	RX Ring	90		40
Line 16	TX Tip	17	16	Not connected
	TX Ring	67	41	
	RX Tip	41	Not connected	16
	RX Ring	91		41
Line 17	TX Tip	18	17	Not connected
	TX Ring	68	42	
	RX Tip	42	Not connected	17
	RX Ring	92		42
Line 18	TX Tip	19	18	Not connected
	TX Ring	69	43	
	RX Tip	43	Not connected	18
	RX Ring	93		43
Line 19	TX Tip	20	19	Not connected
	TX Ring	70	44	
	RX Tip	44	Not connected	19
	RX Ring	94		44
Line 20	TX Tip	21	20	Not connected
	TX Ring	71	45	
	RX Tip	45	Not connected	20
	RX Ring	95		45
Line 21	TX Tip	22	21	Not connected
	TX Ring	72	46	
	RX Tip	46	Not connected	21
	RX Ring	96		46
Line 22	TX Tip	23	22	Not connected
	TX Ring	73	47	
	RX Tip	47	Not connected	22
	RX Ring	97		47
Line 23	TX Tip	24	23	Not connected
	TX Ring	74	48	
	RX Tip	48	Not connected	23
	RX Ring	98		48

**Table 3-53 24-Port Channelized T1/E1 ATM CEoP SPA Cable Connector Pinouts (continued)**

Subscriber		Connector Pins		
Line	Signal	SPA	TX Cable Lead	RX Cable Lead
Line 24	TX Tip	25	24	Not connected
	TX Ring	75	49	
	RX Tip	49	Not connected	24
	RX Ring	99		49

## RJ-45 Cable Pinouts

T1 lines from individual subscribers are attached to the RJ-45 connectors on the front of the 24-port patch panel. Each RJ-45 port accommodates an individual T1 subscriber line.

Pins 1 and 2 and 4 and 5 of the RJ-45 connectors are used for the 24-port CEoP SPA's Transmit (TX) and Receive (RX) signals. Depending on how the cable is installed between the SPA and its patch panel (rear), the RJ-45 connectors operate as follows:

- If the TX cable lead is connected to Transmit on the patch panel and RX is connected to Receive:
  - The SPA's TX signals are transmitted on RJ-45 pins 1 (ring) and 2 (tip).
  - The SPA's RX signals are received on RJ-45 pins 4 (ring) and 5 (tip).
- If the TX cable lead is connected to Receive on the patch panel and RX is connected to Transmit:
  - RJ-45 pins 1 and 2 are used for the SPA's RX signal.
  - RJ-45 pins 4 and 5 are used for the SPA's TX signal.

## Patch Panel Cabling

If you are connecting two 24-Port Channelized T1/E1/J1 CEoP SPAs to each other, you must cable both the SPA's patch panels together using a T1 crossover cable or a T1 straight through cable. The type of cable you use (crossover or straight through) depends on how the CEoP SPAs are cabled to their patch panels:

- If both the CEoP SPAs are connected to their patch panels in the same manner (TX to Transmit and RX to Receive, or TX to Receive and RX to Transmit), use a T1 crossover cable to connect the patch panels to each other.
- If both the CEoP SPAs are connected to their patch panels in a different configuration (TX to Transmit and RX to Receive on one SPA, and TX to Receive and RX to Transmit on the other SPA), use a T1 straight through cable (standard RJ-45 patch cable) between the patch panels.

## 24-Port Channelized T1/E1/J1 CEoP SPA Patch Panel

A 24-port channelized T1/E1/J1 CEoP SPA patch panel with the DCC2484/25T1-S part number is available from Optical Cable Corporation (OCC) at:

<http://www.occfiber.com/main/index.php>

This is a shielded rack mount 24-port patch panel, 2RU, accessory component for the Cisco PID SPA-24CHT1-CE-ATM. You can view the image of patch panel with the DCC2484/25T1-S part number at:

<http://www.occfiber.com/main/index.php?m=1&p=2&s=Y&l=en&it=54&i=193>





## Preparing to Install a SIP or a SPA

---

This chapter describes the general equipment, safety, and site preparation requirements for installing SIPs and SPAs. This chapter contains the following sections:

- [Required Tools and Equipment, page 4-1](#)
- [Safety Guidelines, page 4-1](#)
- [Laser/LED Safety, page 4-9](#)

### Required Tools and Equipment

You need the following tools and parts to install SIPs and SPAs. If you need additional equipment, contact a service representative for ordering information.

- Shared port adapter interface processor (SIP)
- Shared port adapter (SPA)
- Number 1 Phillips screwdriver
- Number 2 Phillips screwdriver
- 3/16-inch flat-blade screwdriver
- Your own electrostatic discharge (ESD)-prevention equipment or the disposable grounding wrist strap supplied with the SIP or SPA
- Antistatic mat
- Antistatic container

### Safety Guidelines

This section provides safety guidelines that you should follow when working with any equipment that connects to electrical power or telephone wiring.

### Safety Warnings

Safety warnings appear throughout this publication in procedures that, if performed incorrectly, might harm you. A warning symbol precedes each warning statement.

## Warning Definition



Warning

### IMPORTANT SAFETY INSTRUCTIONS

This warning symbol means danger. You are in a situation that could cause bodily injury. Before you work on any equipment, be aware of the hazards involved with electrical circuitry and be familiar with standard practices for preventing accidents. Use the statement number provided at the end of each warning to locate its translation in the translated safety warnings that accompanied this device. Statement 1071

### SAVE THESE INSTRUCTIONS

Waarschuwing

### BELANGRIJKE VEILIGHEIDSINSTRUCTIES

Dit waarschuwingssymbool betekent gevaar. U verkeert in een situatie die lichamelijk letsel kan veroorzaken. Voordat u aan enige apparatuur gaat werken, dient u zich bewust te zijn van de bij elektrische schakelingen betrokken risico's en dient u op de hoogte te zijn van de standaard praktijken om ongelukken te voorkomen. Gebruik het nummer van de verklaring onderaan de waarschuwing als u een vertaling van de waarschuwing die bij het apparaat wordt geleverd, wilt raadplegen.

### BEWAAR DEZE INSTRUCTIES

Varoitus

### TÄRKEITÄ TURVALLISUUSOHJEITA

Tämä varoitusmerkki merkitsee vaaraa. Tilanne voi aiheuttaa ruumiillisia vammoja. Ennen kuin käsittelet laitteistoa, huomioi sähköpiirien käsittelemiseen liittyvät riskit ja tutustu onnettomuuksien yleisiin ehkäisytapoihin. Turvallisuusvaroitusten käännökset löytyvät laitteen mukana toimitettujen käännettyjen turvallisuusvaroitusten joukosta varoitusten lopussa näkyvien lausuntonumeroiden avulla.

### SÄILYTÄ NÄMÄ OHJEET

Attention

### IMPORTANTES INFORMATIONS DE SÉCURITÉ

Ce symbole d'avertissement indique un danger. Vous vous trouvez dans une situation pouvant entraîner des blessures ou des dommages corporels. Avant de travailler sur un équipement, soyez conscient des dangers liés aux circuits électriques et familiarisez-vous avec les procédures couramment utilisées pour éviter les accidents. Pour prendre connaissance des traductions des avertissements figurant dans les consignes de sécurité traduites qui accompagnent cet appareil, référez-vous au numéro de l'instruction situé à la fin de chaque avertissement.

### CONSERVEZ CES INFORMATIONS

Warnung

### WICHTIGE SICHERHEITSHINWEISE

Dieses Warnsymbol bedeutet Gefahr. Sie befinden sich in einer Situation, die zu Verletzungen führen kann. Machen Sie sich vor der Arbeit mit Geräten mit den Gefahren elektrischer Schaltungen und den üblichen Verfahren zur Vorbeugung vor Unfällen vertraut. Suchen Sie mit der am Ende jeder Warnung angegebenen Anweisungsnummer nach der jeweiligen Übersetzung in den übersetzten Sicherheitshinweisen, die zusammen mit diesem Gerät ausgeliefert wurden.

### BEWAHREN SIE DIESE HINWEISE GUT AUF.



**Avvertenza      IMPORTANTI ISTRUZIONI SULLA SICUREZZA**

Questo simbolo di avvertenza indica un pericolo. La situazione potrebbe causare infortuni alle persone. Prima di intervenire su qualsiasi apparecchiatura, occorre essere al corrente dei pericoli relativi ai circuiti elettrici e conoscere le procedure standard per la prevenzione di incidenti. Utilizzare il numero di istruzione presente alla fine di ciascuna avvertenza per individuare le traduzioni delle avvertenze riportate in questo documento.

**CONSERVARE QUESTE ISTRUZIONI****Advarsel      VIKTIGE SIKKERHETSINSTRUKSJONER**

Dette advarselssymbolet betyr fare. Du er i en situasjon som kan føre til skade på person. Før du begynner å arbeide med noe av utstyret, må du være oppmerksom på farene forbundet med elektriske kretser, og kjenne til standardprosedyrer for å forhindre ulykker. Bruk nummeret i slutten av hver advarsel for å finne oversettelsen i de oversatte sikkerhetsadvarslene som fulgte med denne enheten.

**TA VARE PÅ DISSE INSTRUKSJONENE****Aviso      INSTRUÇÕES IMPORTANTES DE SEGURANÇA**

Este símbolo de aviso significa perigo. Você está em uma situação que poderá ser causadora de lesões corporais. Antes de iniciar a utilização de qualquer equipamento, tenha conhecimento dos perigos envolvidos no manuseio de circuitos elétricos e familiarize-se com as práticas habituais de prevenção de acidentes. Utilize o número da instrução fornecido ao final de cada aviso para localizar sua tradução nos avisos de segurança traduzidos que acompanham este dispositivo.

**GUARDE ESTAS INSTRUÇÕES****¡Advertencia!      INSTRUCCIONES IMPORTANTES DE SEGURIDAD**

Este símbolo de aviso indica peligro. Existe riesgo para su integridad física. Antes de manipular cualquier equipo, considere los riesgos de la corriente eléctrica y familiarícese con los procedimientos estándar de prevención de accidentes. Al final de cada advertencia encontrará el número que le ayudará a encontrar el texto traducido en el apartado de traducciones que acompaña a este dispositivo.

**GUARDE ESTAS INSTRUCCIONES****Varning!      VIKTIGA SÄKERHETSANVISNINGAR**

Denna varningssignal signalerar fara. Du befinner dig i en situation som kan leda till personskada. Innan du utför arbete på någon utrustning måste du vara medveten om farorna med elkretsar och känna till vanliga förfaranden för att förebygga olyckor. Använd det nummer som finns i slutet av varje varning för att hitta dess översättning i de översatta säkerhetsvarningar som medföljer denna anordning.

**SPARA DESSA ANVISNINGAR**

**Figyelem FONTOS BIZTONSÁGI ELOÍRÁSOK**

Ez a figyelmeztető jel veszélyre utal. Sérülésveszélyt rejtő helyzetben van. Mielott bármely berendezésen munkát végezte, legyen figyelemmel az elektromos áramkörök okozta kockázatokra, és ismerkedjen meg a szokásos balesetvédelmi eljárásokkal. A kiadványban szereplő figyelmeztetések fordítása a készülékhez mellékelt biztonsági figyelmeztetések között található; a fordítás az egyes figyelmeztetések végén látható szám alapján kereshető meg.

**ORIZZE MEG EZEKET AZ UTASÍTÁSOKAT!****Предупреждение ВАЖНЫЕ ИНСТРУКЦИИ ПО СОБЛЮДЕНИЮ ТЕХНИКИ БЕЗОПАСНОСТИ**

Этот символ предупреждения обозначает опасность. То есть имеет место ситуация, в которой следует опасаться телесных повреждений. Перед эксплуатацией оборудования выясните, каким опасностям может подвергаться пользователь при использовании электрических цепей, и ознакомьтесь с правилами техники безопасности для предотвращения возможных несчастных случаев. Воспользуйтесь номером заявления, приведенным в конце каждого предупреждения, чтобы найти его переведенный вариант в переводе предупреждений по безопасности, прилагаемом к данному устройству.

**СОХРАНИТЕ ЭТИ ИНСТРУКЦИИ****警告 重要的安全性说明**

此警告符号代表危险。您正处于可能受到严重伤害的工作环境中。在您使用设备开始工作之前，必须充分意识到触电的危险，并熟练掌握防止事故发生的标准工作程序。请根据每项警告结尾提供的声明号码来找到此设备的安全性警告说明的翻译文本。

请保存这些安全性说明

**警告 安全上の重要な注意事項**

「危険」の意味です。人身事故を予防するための注意事項が記述されています。装置の取り扱い作業を行うときは、電気回路の危険性に注意し、一般的な事故防止策に留意してください。警告の各国語版は、各注意事項の番号を基に、装置に付属の「Translated Safety Warnings」を参照してください。

これらの注意事項を保管しておいてください。

**주의 중요 안전 지침**

이 경고 기호는 위험을 나타냅니다. 작업자가 신체 부상을 일으킬 수 있는 위험한 환경에 있습니다. 장비에 작업을 수행하기 전에 전기 회로와 관련된 위험을 숙지하고 표준 작업 관례를 숙지하여 사고를 방지하십시오. 각 경고의 마지막 부분에 있는 경고문 번호를 참조하여 이 장치와 함께 제공되는 번역된 안전 경고문에서 해당 번역문을 찾으십시오.

이 지시 사항을 보관하십시오.

## تحذير

## إرشادات الأمان الهامة

يوضح رمز التحذير هذا وجود خطر. وهذا يعني أنك متواجد في مكان قد ينتج عنه التعرض لإصابات. قبل بدء العمل، احذر مخاطر التعرض للصدمات الكهربائية وكن على علم بالإجراءات القياسية للحيولة دون وقوع أي حوادث. استخدم رقم البيان الموجود في آخر كل تحذير لتحديد مكان ترجمته داخل تحذيرات الأمان المترجمة التي تأتي مع الجهاز. قم بحفظ هذه الإرشادات

## Upozorenje

## VAŽNE SIGURNOSNE NAPOMENE

Ovaj simbol upozorenja predstavlja opasnost. Nalazite se u situaciji koja može prouzročiti tjelesne ozljede. Prije rada s bilo kojim uređajem, morate razumjeti opasnosti vezane uz električne sklopove, te biti upoznati sa standardnim načinima izbjegavanja nesreća. U prevedenim sigurnosnim upozorenjima, priloženima uz uređaj, možete prema broju koji se nalazi uz pojedino upozorenje pronaći i njegov prijevod.

## SAČUVAJTE OVE UPUTE

## Upozornění

## DŮLEŽITÉ BEZPEČNOSTNÍ POKYNY

Tento upozorňující symbol označuje nebezpečí. Jste v situaci, která by mohla způsobit nebezpečí úrazu. Před prací na jakémkoliv vybavení si uvědomte nebezpečí související s elektrickými obvody a seznamte se se standardními opatřeními pro předcházení úrazům. Podle čísla na konci každého upozornění vyhledejte jeho překlad v přeložených bezpečnostních upozorněních, která jsou přiložena k zařízení.

## USCHOVEJTE TYTO POKYNY

## Προειδοποίηση

## ΣΗΜΑΝΤΙΚΕΣ ΟΔΗΓΙΕΣ ΑΣΦΑΛΕΙΑΣ

Αυτό το προειδοποιητικό σύμβολο σημαίνει κίνδυνο. Βρίσκεστε σε κατάσταση που μπορεί να προκαλέσει τραυματισμό. Πριν εργαστείτε σε οποιοδήποτε εξοπλισμό, να έχετε υπόψη σας τους κινδύνους που σχετίζονται με τα ηλεκτρικά κυκλώματα και να έχετε εξοικειωθεί με τις συνήθειες πρακτικές για την αποφυγή ατυχημάτων. Χρησιμοποιήστε τον αριθμό δήλωσης που παρέχεται στο τέλος κάθε προειδοποίησης, για να εντοπίσετε τη μετάφρασή της στις μεταφρασμένες προειδοποιήσεις ασφαλείας που συνοδεύουν τη συσκευή.

## ΦΥΛΑΞΤΕ ΑΥΤΕΣ ΤΙΣ ΟΔΗΓΙΕΣ

## אזהרה

## הוראות בטיחות חשובות

סימן אזהרה זה מסמל סכנה. אתה נמצא במצב העלול לגרום לפציעה. לפני שתעבוד עם ציוד כלשהו, עליך להיות מודע לסכנות הכרוכות במעגלים חשמליים ולהכיר את הנהלים המקובלים למניעת תאונות. השתמש במספר ההוראה המסופק בסופה של כל אזהרה כדי לאתר את התרגום באזהרות הבטיחות המתורגמות שמצורפות להתקן.

## שמור הוראות אלה

**Ostrzeżenie WAŻNE INSTRUKCJE DOTYCZĄCE BEZPIECZEŃSTWA**

Ten symbol ostrzeżenia oznacza niebezpieczeństwo. Zachodzi sytuacja, która może powodować obrażenia ciała. Przed przystąpieniem do prac przy urządzeniach należy zapoznać się z zagrożeniami związanymi z układami elektrycznymi oraz ze standardowymi środkami zapobiegania wypadkom. Na końcu każdego ostrzeżenia podano numer, na podstawie którego można odszukać tłumaczenie tego ostrzeżenia w dołączonym do urządzenia dokumencie z tłumaczeniami ostrzeżeń.

**NINIEJSZE INSTRUKCJE NALEŻY ZACHOWAĆ****Upozornenie DŮLEŽITÉ BEZPEČNOSTNÉ POKYNY**

Tento varovný symbol označuje nebezpečenstvo. Nachádzate sa v situácii s nebezpečenstvom úrazu. Pred prácou na akomkoľvek vybavení si uvedomte nebezpečenstvo súvisiace s elektrickými obvodmi a oboznámte sa so štandardnými opatreniami na predchádzanie úrazom. Podľa čísla na konci každého upozornenia vyhľadajte jeho preklad v preložených bezpečnostných upozorneniach, ktoré sú priložené k zariadeniu.

**USCHOVAJTE SI TENTO NÁVOD****Warning**

**Do not work on the system or connect or disconnect cables during periods of lightning activity.**  
Statement 1001

---

**Warning**

**To avoid electric shock, do not connect safety extra-low voltage (SELV) circuits to telephone-network voltage (TNV) circuits. LAN ports contain SELV circuits, and WAN ports contain TNV circuits. Some LAN and WAN ports both use RJ-45 connectors. Use caution when connecting cables.** Statement 1021

---

**Warning**

**Hazardous network voltages are present in WAN ports regardless of whether power to the unit is OFF or ON. To avoid electric shock, use caution when working near WAN ports. When detaching cables, detach the end away from the unit first.** Statement 1026

---

**Warning**









**Blank faceplates and cover panels serve three important functions: they prevent exposure to hazardous voltages and currents inside the chassis; they contain electromagnetic interference (EMI) that might disrupt other equipment; and they direct the flow of cooling air through the chassis. Do not operate the system unless all cards, faceplates, front covers, and rear covers are in place.**  
Statement 1029

---

**Warning**

**Hazardous voltage or energy is present on the backplane when the system is operating. Use caution when servicing.** Statement 1034

---

-  **Warning** Do not use this product near water; for example, near a bath tub, wash bowl, kitchen sink or laundry tub, in a wet basement, or near a swimming pool. Statement 1035
-  **Warning** Never install telephone jacks in wet locations unless the jack is specifically designed for wet locations. Statement 1036
-  **Warning** Never touch uninsulated telephone wires or terminals unless the telephone line has been disconnected at the network interface. Statement 1037
-  **Warning** Avoid using a telephone (other than a cordless type) during an electrical storm. There may be a remote risk of electric shock from lightning. Statement 1038
-  **Warning** To report a gas leak, do not use a telephone in the vicinity of the leak. Statement 1039
-  **Warning** Before opening the unit, disconnect the telephone-network cables to avoid contact with telephone-network voltages. Statement 1041
-  **Warning** This equipment must be installed and maintained by service personnel as defined by AS/NZS 3260. Incorrectly connecting this equipment to a general-purpose outlet could be hazardous. The telecommunications lines must be disconnected 1) before unplugging the main power connector or 2) while the housing is open, or both. Statement 1043
-  **Warning** The covers are an integral part of the safety design of the product. Do not operate the unit without the covers installed. Statement 1077

## Electrical Equipment Guidelines

Follow these basic guidelines when working with any electrical equipment:

- Before beginning any procedures requiring access to the chassis interior, locate the emergency power-off switch for the room in which you are working.
- Disconnect all power and external cables before moving a chassis.
- Do not work alone when potentially hazardous conditions exist.
- Never assume that power has been disconnected from a circuit; always check.
- Do not perform any action that creates a potential hazard to people or makes the equipment unsafe; carefully examine your work area for possible hazards such as moist floors, ungrounded power extension cables, and missing safety grounds.



**Caution**

---

This equipment is suitable for intrabuilding wiring only.

---

## Telephone Wiring Guidelines

Use the following guidelines when working with any equipment that is connected to telephone wiring or to other network cabling:

- Never install telephone wiring during a lightning storm.
- Never install telephone jacks in wet locations unless the jack is specifically designed for wet locations.
- Never touch uninsulated telephone wires or terminals unless the telephone line has been disconnected at the network interface.
- Use caution when installing or modifying telephone lines.

## Preventing Electrostatic Discharge Damage

Electrostatic discharge (ESD) damage, which can occur when electronic cards or components are improperly handled, results in complete or intermittent failures. SIPs, SPAs, and processor modules comprise printed circuit boards that are fixed in metal carriers. Electromagnetic interference (EMI) shielding and connectors are integral components of the carrier. Although the metal carrier helps to protect the board from ESD, use a preventive antistatic strap during handling.

Following are guidelines for preventing ESD damage:

- Always use an ESD wrist or ankle strap and ensure that it makes good skin contact.
- Connect the equipment end of the strap to an unfinished chassis surface.
- When installing a component, use any available ejector levers or captive installation screws to properly seat the bus connectors in the backplane or midplane. These devices prevent accidental removal, provide proper grounding for the system, and help to ensure that bus connectors are properly seated.
- When removing a component, use any available ejector levers or captive installation screws to release the bus connectors from the backplane or midplane.
- Handle carriers by available handles or edges only; avoid touching the printed circuit boards or connectors.

- Place a removed board component-side-up on an antistatic surface or in a static shielding container. If you plan to return the component to the factory, immediately place it in a static shielding container.
- Avoid contact between the printed circuit boards and clothing. The wrist strap only protects components from ESD voltages on the body; ESD voltages on clothing can still cause damage.
- Never attempt to remove the printed circuit board from the metal carrier.

**Caution**

For safety, periodically check the resistance value of the antistatic strap. The measurement should be between 1 and 10 megohms (Mohms).

## Laser/LED Safety

An optical single-mode transmitter uses a small laser to transmit the light signal to the network ring. Keep the transmit port covered whenever a cable is not connected to it. Although multimode transceivers typically use LEDs for transmission, it is good practice to keep open ports covered and avoid staring into open ports or apertures. The single-mode aperture port contains a laser warning label, as shown in [Figure 4-1](#). The multimode aperture contains a Class 1 LED warning label, as shown in [Figure 4-2](#). These warnings apply to SPAs and SFP modules that transmit signals via an optical carrier signal.

**Figure 4-1 Class 1 Laser Warning Labels for Single-Mode Port**



**Figure 4-2 Class 1 LED Warning Label for Multimode Port**

**Warning**

**Class 1 laser product.** Statement 1008

**Warning**

**Class 1 LED product.** Statement 1027

**Warning**

**Invisible laser radiation may be emitted from disconnected fibers or connectors. Do not stare into beams or view directly with optical instruments.** Statement 1051







## Installing and Removing a SIP

---

This chapter describes how to install or remove SIPs on the Cisco ASR 1000 Series Aggregation Services Routers. This chapter contains the following sections:

- [Handling SIPs, page 5-1](#)
- [Online Insertion and Removal, page 5-2](#)
- [SIP Installation and Removal, page 5-9](#)

### Handling SIPs

Each SIP circuit board is mounted to a metal carrier and is sensitive to electrostatic discharge (ESD) damage. See the [“Preventing Electrostatic Discharge Damage”](#) section on page 4-8 for ESD precautions.

Before you begin installation, read [Chapter 4, “Preparing to Install a SIP or a SPA,”](#) for a list of parts and tools required for installation.



#### Caution

---

Always handle the SIP by the carrier edges and handle; never touch the SIP components or connector pins. (See [Figure 5-1](#).)

---

When a slot is not in use, a blank filler plate must be installed in the empty slot to allow the router or switch to conform to electromagnetic interference (EMI) emissions requirements and to allow proper airflow across the installed modules. If you plan to install a SIP in a slot that is not in use, you must first remove the blank filler plate.

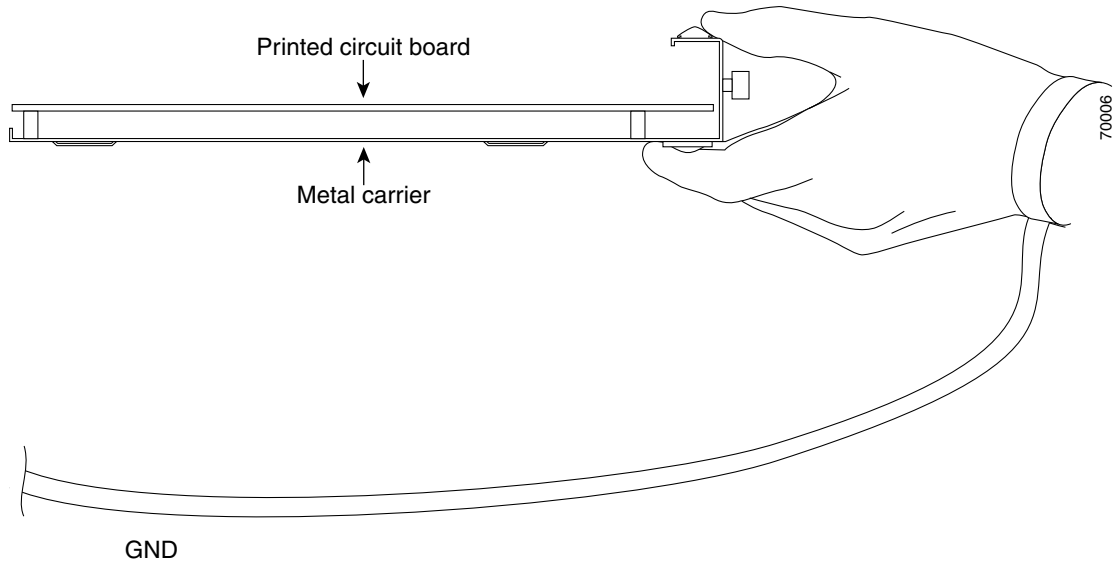
**Figure 5-1 Handling a SIP**

## Online Insertion and Removal

The Cisco ASR 1000 Series Aggregation Services Routers support online insertion and removal (OIR) of the SPA interface processor (SIP), in addition to each of the shared port adapters (SPAs). Therefore, you can remove a SIP with its SPAs still intact, or you can remove a SPA independently from the SIP, leaving the SIP installed in the router.

This section includes the following topics on OIR support:

- [Preparing for Online Removal of a SIP, page 5-2](#)
- [Verifying the Deactivation and Activation of a SIP, page 5-4](#)
- [Preparing for Online Removal of a SPA, page 5-5](#)
- [Verifying the Deactivation and Activation of a SPA, page 5-8](#)
- [Deactivation and Activation Configuration Examples, page 5-8](#)

## Preparing for Online Removal of a SIP

The Cisco ASR 1000 Series Aggregation Services Routers support OIR of the SIP. To perform an OIR, power down a SIP which automatically deactivates any installed SPAs and remove the SIP with the SPAs still intact.



### Note

If SIP-40 is installed with the bandwidth value greater than 11.2G and if SIP-40 is replaced with SIP-10 then the bandwidth of SIP-10 is reset to its default maximum bandwidth of 11.2G. An informational message indicating “Setting input bandwidth to ESI max bandwidth: 11199896” is displayed on the console. This message is displayed when SIP-40 is downgraded to SIP-10 from Cisco IOS XE Release 3.1.0S onwards.

Although graceful deactivation of a SIP is recommended using the **hw-module slot stop** command, the Cisco ASR 1000 Series Aggregation Services Routers support the removal of the SIP without deactivating it first. If you plan to remove a SIP, deactivate the SIP first, using the **hw-module slot stop** command in global configuration mode. When you deactivate a SIP using this command, it automatically deactivates each of the SPAs that are installed in that SIP. Therefore, it is not necessary to deactivate each of the SPAs prior to deactivating the SIP.

Either a blank filler plate or a functional SPA should reside in every subslot of a SIP during normal operation.

**Note**

It is recommended that you stop any traffic, and then stop the card using **hw-module slot <> stop** command in privileged EXEC mode and wait for at-least 60 sec before swapping carrier cards.

## Deactivating a SIP

To deactivate a SIP and its installed SPAs prior to removal of the SIP, use the following command in global configuration mode:

Command	Purpose
Router(config)# <b>hw-module slot <i>slot-number</i> stop</b>	Shuts down any installed interfaces, and deactivates the SIP in the specified slot, where: <ul style="list-style-type: none"> <li>• <i>slot-number</i>—Specifies the SIP chassis slot number where the SIP is installed.</li> <li>• <b>stop</b>—Deactivates the SIP and places it in reset mode.</li> </ul>

For more information about chassis slot numbering, see the [“Identifying Slots and Subslots for SIPs and SPAs” section on page 2-3](#).

## Reactivating a SIP

If you did deactivate the SIP using the **hw-module slot stop** command, then you do not need to reactivate the SPAs after an OIR of the SIP. The installed SPAs automatically reactivate upon reactivation of the SIP in the Cisco ASR 1000 Series Router.

For example, consider the case where you remove a SIP from the Cisco ASR 1000 Series Router to replace it with another SIP. You reinstall the same SPAs into the new SIP. When you enter the **hw-module slot start** command on the Cisco ASR 1000 Series Router, the SPAs automatically reactivate with the new SIP.

To activate a SIP and its installed SPAs after the SIP has been deactivated, use the following command in global configuration mode:

Command	Purpose
Router(config)# <b>hw-module slot slot-number start</b>	<p>Activates the SIP in the specified slot and its installed SPAs, where:</p> <ul style="list-style-type: none"> <li><i>slot-number</i>—Specifies the SIP chassis slot number where the SIP is installed.</li> <li><b>start</b>—Activates the SIP and removes it from reset mode.</li> </ul>

For more information about chassis slot numbering, see the “[Identifying Slots and Subslots for SIPs and SPAs](#)” section on page 2-3.

## Verifying the Deactivation and Activation of a SIP

To verify the deactivation of a SIP, enter the **show platform** command in privileged EXEC configuration mode. Observe the State field associated with the SIP that you want to verify.

The following example shows that the Cisco ASR1000-SIP10 located in slot 1 is deactivated.

```
Router# show platform
Chassis type: ASR1006
```

Slot	Type	State	Insert time (ago)
0	ASR1000-SIP10	ok	2d20h
0/0	SPA-1XOC12-POS	ok	2d20h
0/1	SPA-1XOC12-POS	ok	1d21h
0/2	SPA-5X1GE-V2	ok	2d20h
0/3	SPA-4XOC3-POS-V2	ok	2d20h
1	ASR1000-SIP10	disabled	1d23h
R0	ASR1000-RP1	ok, active	1w3d
F0	ASR1000-ESP10	ok, active	1w3d
P0	Unknown	ps, fail	never
P1	Unknown	ps, fail	never

Slot	CPLD Version	Firmware Version
0	06120701	12.2(20071009:051408) [gschnorr-mcp_...
1	07091401	12.2(20070807:170946) [gschnorr-mcp_...
R0	07010515	12.2(33r)XN2
F0	07021400	12.2(20071030:180953) [gschnorr-mcp_...

To verify activation and proper operation of a SIP, enter the **show platform** command and observe “ok” in the State field as shown in the following example:

```
Router# show platform
Chassis type: ASR1006
```

Slot	Type	State	Insert time (ago)
0	ASR1000-SIP10	ok	03:19:46
0/0	SPA-5X1GE-V2	ok	03:18:28
0/1	SPA-8X1FE-TX-V2	ok	03:18:28
0/2	SPA-2XCT3/DS0	ok	03:18:19
1	ASR1000-SIP10	ok	03:19:46
1/0	SPA-2XOC3-POS	ok	03:18:28

```

1/1    SPA-8XCHT1/E1    ok                03:18:28
1/2    SPA-2XT3/E3      ok                03:18:18
R0     ASR1000-RP1      ok, active        03:19:46
F0     ASR1000-ESP10   ok, active        03:19:46
P0     ASR1006-PWR-AC   ok                03:19:14
P1     ASR1006-FAN     ok                03:19:14

```

The following example shows the Cisco ASR 1000-SIP10 installed in slot 0 and Cisco ASR1000-SIP40 installed in slots 1,2,3, and 4 of the Cisco ASR 1013 Router:

```

Router# show platform
Chassis type: ASR1013

```

Slot	Type	State	Insert time (ago)
0	ASR1000-SIP10	ok	1w0d
1	ASR1000-SIP40	ok	1w0d
1/1	SPA-5X1GE-V2	ok	1w0d
2	ASR1000-SIP40	ok	1w0d
2/1	SPA-1X10GE-L-V2	ok	1w0d
2/3	SPA-1X10GE-L-V2	ok	1w0d
3	ASR1000-SIP40	ok	1w0d
3/3	SPA-4XT3/E3	ok	1w0d
4	ASR1000-SIP40	ok	1w0d
4/2	SPA-5X1GE-V2	ok	1w0d
4/3	SPA-4XCT3/DSO	ok	1w0d
5	ASR1000-SIP40	ok	1w0d
R0	ASR1000-RP2	ok, active	1w0d
R1	ASR1000-RP2	ok, standby	1w0d
F0	ASR1000-ESP40	ok, active	1w0d
P0	ASR1013-PWR-AC	ok	1w0d
P1	ASR1013-PWR-AC	ps, fail	1w0d
P2	ASR1013-PWR-AC	ok	1w0d
P3	ASR1013-PWR-AC	ps, fail	1w0d

Slot	CPLD Version	Firmware Version
0	00200800	15.0(1r)S
1	00200800	15.0(1r)S
2	00200800	15.0(1r)S
3	00200800	15.0(1r)S
4	00200800	15.0(1r)S
5	00200800	15.0(1r)S
R0	10021901	15.0(1r)S
R1	10021901	15.0(1r)S
F0	1001270D	15.0(1r)S

## Preparing for Online Removal of a SPA

The Cisco ASR 1000 Series Routers support the OIR of a SPA independent of removing the SIP. This means that a SIP can remain installed in the Cisco ASR 1000 Series Router with one SPA remaining active, while you remove another SPA from one of the SIP subslots. If you are not planning to immediately replace a SPA into the SIP, ensure that you install a blank filler plate in the subslot. The SIP should always be fully installed with either functional SPAs or blank filler plates.

If you are planning to remove a SIP along with its SPAs, you do not have to follow the instructions provided in this section. To remove a SIP, see the [“Preparing for Online Removal of a SIP”](#) section on page 5-2.

## Deactivating a SPA

Although graceful deactivation of a SPA is recommended using the **hw-module subslot stop** command in EXEC mode, the Cisco ASR 1000 Series Routers support the removal of the SPA without deactivating it first. Before deactivating a SPA, ensure that the SIP is seated securely in the slot before you pull out the SPA.



### Note

If you are preparing for an OIR of a SPA, it is not necessary to independently shut down each of the interfaces prior to deactivation of the SPA. The **hw-module slot stop** command in EXEC mode automatically stops traffic on the interfaces and deactivates them along with the SPA in preparation for OIR. In similar fashion, you do not need to independently restart any interfaces on a SPA after OIR of a SPA or SIP.

Enter the **show facility-alarm status** command. The following example shows a critical alarm that is generated when a SPA is removed from the system:

```
Router# show facility-alarm status
System Totals  Critical: 1  Major: 0  Minor: 0
Source          Severity      Description [Index]
-----
subslot 1/1     CRITICAL     Active Card Removed OIR Alarm [0]
```



### Note

A critical alarm "Active Card Removed OIR Alarm" is generated even if a SPA is removed after performing graceful deactivation.

## Choosing the Mode of the hw-module subslot Command

You can deactivate a SPA and all of its interfaces by using the **hw-module subslot** command in one of two modes:

- If you choose to use the **hw-module subslot shutdown** command in global configuration mode, you change the configuration so that no matter how many times the router is rebooted, the SPA will not boot. This command is useful when you need to shut down a SPA in a remote location and ensure that it does not come back up if the router is rebooted.
- If you choose to use the **hw-module subslot stop** command in EXEC mode, you cause the SPA to gracefully shut down. However, the SPA will come up again when executing the **hw-module subslot start** command.

To deactivate a SPA and all of its interfaces prior to removal of the SPA, use one of the following commands in global configuration mode:

Command or Action	Purpose
Router(config)# <b>hw-module subslot</b> <i>slot-number/subslot-number shutdown [powered   unpowered]</i>	Deactivates the SPA in the specified slot and subslot of the SIP, where: <ul style="list-style-type: none"> <li>• <i>slot-number</i>—Specifies the chassis slot number where the SIP is installed.</li> <li>• <i>subslot-number</i>—Specifies the subslot number on a SIP where a SPA is installed.</li> <li>• <b>shutdown</b>—Shuts down the specified SPA.</li> <li>• <b>powered</b>—(Optional) Shuts down the SPA and all of its interfaces, and leaves them in an administratively down state with power enabled. This is the default state.</li> <li>• <b>unpowered</b>—(Optional) Shuts down the SPA and all of its interfaces, and leaves them in an administratively down state without power.</li> </ul>
Router(config)# <b>hw-module subslot</b> <i>slot-number/subslot-number {reload   stop   start}</i>	Deactivates the SPA in the specified slot and subslot of the SIP, where: <ul style="list-style-type: none"> <li>• <i>slot-number</i>—Specifies the chassis slot number where the SIP is installed.</li> <li>• <i>subslot-number</i>—Specifies the subslot number on a SIP where a SPA is installed.</li> <li>• <b>reload</b>—Stops and restarts the specified SPA.</li> <li>• <b>stop</b>—Stops the specified SPA.</li> <li>• <b>start</b>—Starts the specified SPA.</li> </ul>

For more information about chassis slot and SIP subslot numbering, refer to the [“Identifying Slots and Subslots for SIPs and SPAs”](#) section on page 2-3.

## Reactivating a SPA



### Note

You do not need to reactivate a SPA after an OIR of either the SIP or a SPA if you did not deactivate the SPA prior to removal when using the **hw-module subslot** command in global configuration mode. If the Cisco ASR 1000 Series Router is running, then the SPAs automatically start upon insertion into the SIP or with insertion of a SIP into the Cisco ASR 1000 Series Router.

If you deactivate a SPA using the **hw-module subslot stop** command and need to reactivate it without performing an OIR, you must use the **hw-module subslot start** command to reactivate the SPA and its interfaces.

To activate a SPA and its interfaces after the SPA has been deactivated, use the following command in global configuration mode:

Command	Purpose
Router(config)# <b>no hw-module subslot slot-number/subslot-number shutdown</b>	<p>Activates the SPA and its interfaces in the specified slot and subslot of the SIP, where:</p> <ul style="list-style-type: none"> <li><i>slot-number</i>—Specifies the chassis slot number where the SIP is installed.</li> <li><i>subslot-number</i>—Specifies the subslot number on a SIP where a SPA is installed.</li> </ul>

## Verifying the Deactivation and Activation of a SPA

When you deactivate a SPA, the corresponding interfaces are also deactivated. This means that these interfaces will no longer appear in the output of the **show interface** command.

To verify the deactivation of a SPA, enter the **show hw-module subslot all oir** command in privileged EXEC configuration mode. Observe the Operational Status field associated with the SPA that you want to verify.

In the following example, the SPA located in subslot 1 of the SIP in slot 2 of the Cisco ASR 1000 Series Router is administratively down from the **hw-module subslot shutdown** command:

```
Router# show hw-module subslot all oir
Module           Model                Operational Status
-----
subslot 2/0      SPA-1X10GE-L-V2      ok
subslot 2/1      SPA-8X1GE-v2         admin down
```

To verify activation and proper operation of a SPA, enter the **show hw-module subslot all oir** command and observe “ok” in the Operational Status field as shown in the following example:

```
Router# show hw-module subslot all oir
Module           Model                Operational Status
-----
subslot 2/0      SPA-1X10GE-L-V2      ok
subslot 2/1      SPA-8X1GE-v2         ok
```

## Deactivation and Activation Configuration Examples

This section provides the following examples of deactivating and activating SIPs and SPAs:

- [Deactivation of a SIP Configuration Example, page 5-8](#)
- [Activation of a SIP Configuration Example, page 5-9](#)
- [Deactivation of a SPA Configuration Example, page 5-9](#)
- [Activation of a SPA Configuration Example, page 5-9](#)

### Deactivation of a SIP Configuration Example

Deactivate a SIP when you want to perform OIR of the SIP. The following example deactivates the SIP that is installed in slot 1 of the Cisco ASR 1000 Series Router, its SPAs, and all of the interfaces:

```
Router(config)# hw-module slot 1 stop
```



## Activation of a SIP Configuration Example

Activate a SIP if you have previously deactivated it. If you did not deactivate the SPAs, the SPAs automatically reactivate with reactivation of the SIP.

The following example activates the SIP that is installed in slot 1 of the Cisco ASR 1000 Series Router, its SPAs, and all of the interfaces (as long as the **hw-module subslot shutdown** command was not issued to also deactivate the SPA):

```
Router(config)# hw-module slot 1 start
```

There are no corresponding console messages shown with activation using this command. If you re-enter the **hw-module slot start** command, a message displays indicating that the module is already enabled.

## Deactivation of a SPA Configuration Example

Deactivate a SPA when you want to perform OIR of that SPA. The following example deactivates the SPA (and its interfaces) that is installed in subslot 0 of the SIP located in slot 1 of the Cisco ASR 1000 Series Router and removes power to the SPA.

```
Router(config)# hw-module subslot 1/0 shutdown unpowered
```

## Activation of a SPA Configuration Example

Activate a SPA if you have previously deactivated it. If you have not deactivated a SPA and its interfaces during OIR of a SIP, then the SPA is automatically reactivated upon reactivation of the SIP.

The following example activates the SPA that is installed in subslot 0 of the SIP located in slot 1 of the Cisco ASR 1000 Series Router.

```
Router(config)# no hw-module subslot 1/0 shutdown
```

# SIP Installation and Removal

This section provides step-by-step instructions for installing and removing a SIP.



### Note

The SIP in the Cisco ASR 1002 Router and Cisco ASR 1002-X Router is permanently installed and cannot be removed.



### Caution

When performing the following procedures, wear a grounding wrist strap to avoid ESD damage to the SIP. Some platforms have an ESD connector for attaching the wrist strap. Do not directly touch the midplane or backplane with your hand or any metal tool.

To install a SIP, refer to [Figure 5-2](#) and do the following:

- Step 1** Before inserting a SIP, make sure that the chassis is grounded.
- Step 2** To insert the SIP, carefully align the edges of the SIP between the upper and lower edges of the router slot.
- Step 3** Carefully slide the SIP into the router slot until the SIP makes contact with the backplane.

**Step 4** Tighten the locking thumbscrews on both sides of the SIP.

**Step 5** Connect all cables to each SPA.

---

To remove a SIP, refer to [Figure 5-2](#) and do the following:

---

**Step 1** To remove the SIP, first disconnect all cables from each SPA.

**Step 2** Loosen the locking thumbscrews on both sides of the SIP.

**Step 3** Slide the SIP out of the router slot. If you are removing a blank filler plate, pull the blank filler plate completely out of the router slot.

---

Figure 5-2 illustrates how to install and remove a SIP in Cisco ASR 1000 Series Routers.

Figure 5-2 SIP Installation and Removal

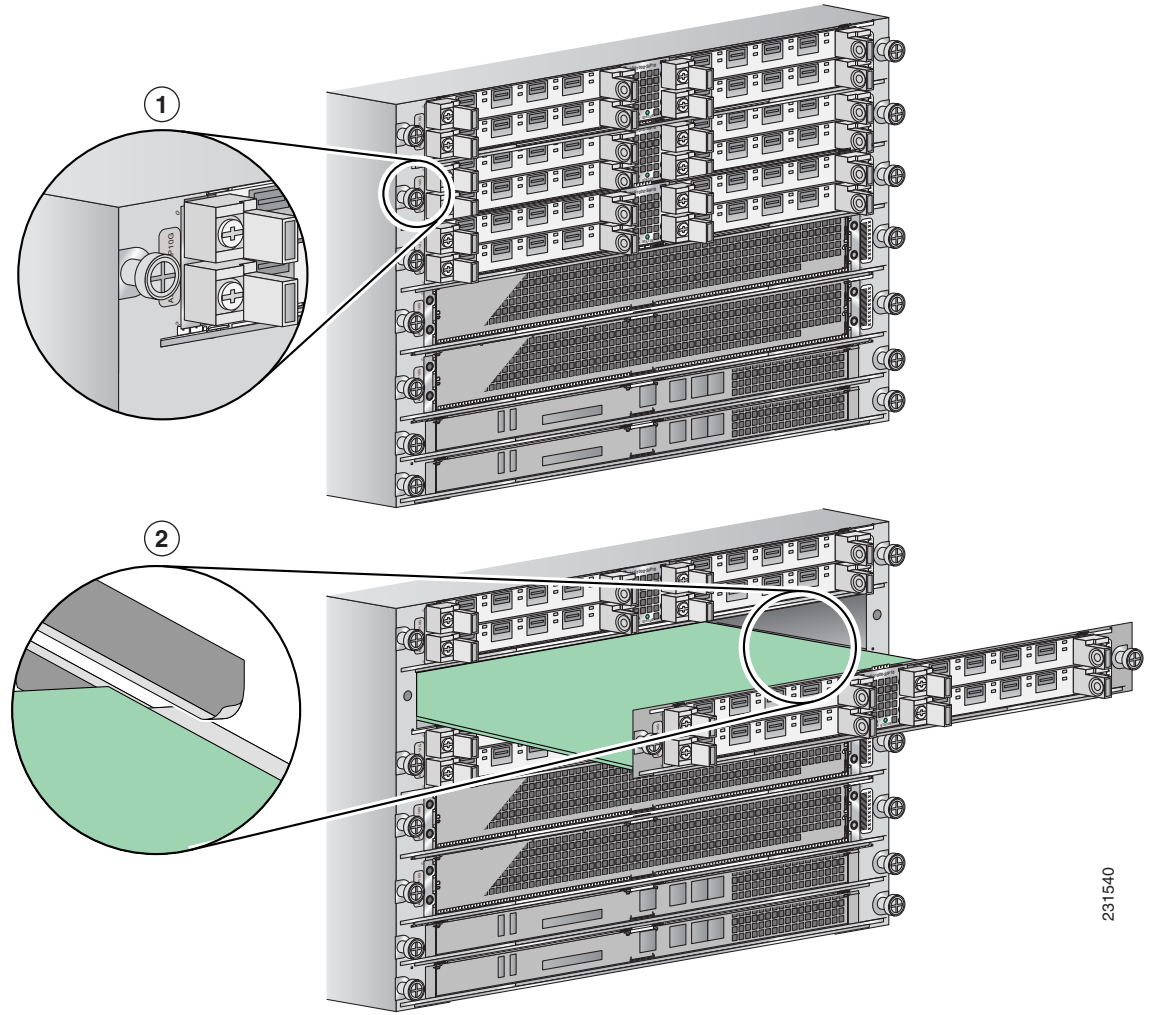

<b>1</b> Captive installation screw	<b>2</b> Guide rails
-------------------------------------	----------------------

231540





## Installing and Removing a SPA

---

This chapter describes how to install or remove SPAs on the Cisco ASR 1000 Series Router. This chapter contains the following sections:

- [Handling SPAs, page 6-1](#)
- [SPA Installation and Removal, page 6-2](#)
- [Online Insertion and Removal, page 6-6](#)
- [Optical Device Maintenance, page 6-6](#)
- [Checking the Installation, page 6-7](#)
- [SPA Blank Filler Plates, page 6-9](#)
- [SPA Cable Management Brackets, page 6-10](#)

### Handling SPAs

Each SPA circuit board is mounted to a metal carrier and is sensitive to electrostatic discharge (ESD) damage. See the [“Preventing Electrostatic Discharge Damage”](#) section on page 4-8 for ESD precautions.

Before you begin installation, read [Chapter 4, “Preparing to Install a SIP or a SPA”](#), for a list of parts and tools required for installation.



#### Caution

---

Always handle the SPA by the carrier edges and handle; never touch the SPA components or connector pins. (See [Figure 6-1](#).)

---

When a subslot is not in use, a SPA blank filler plate must fill the empty subslot to allow the router or switch to conform to electromagnetic interference (EMI) emissions requirements and to allow proper airflow across the SPAs. If you plan to install a SPA in a subslot that is not in use, you must first remove the SPA blank filler plate.

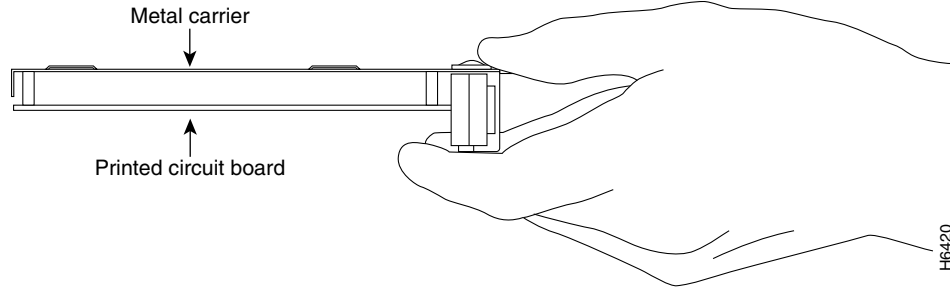
**Figure 6-1 Handling a SPA**

## SPA Installation and Removal

This section provides step-by-step instructions for installing and removing a SPA in a SIP.



### Caution

When performing the following procedures, wear a grounding wrist strap to avoid ESD damage to the SPA. Some platforms have an ESD connector for attaching the wrist strap. Do not directly touch the midplane or backplane with your hand or any metal tool.

See [Preventing Electrostatic Discharge Damage, page 4-8](#) for information about ESD.

## Installing a SPA in a SIP

To install a SPA in a SIP, do the following:

- 
- Step 1** To insert the SPA in the SIP, locate the guide rails inside the SIP that hold the SPA in place. They are at the top left and top right of the SPA slot and are recessed about an inch.
  - Step 2** Carefully slide the SPA all the way in the SIP until the SPA is firmly seated in the SPA interface connector. When fully seated, the SPA might be slightly behind the SIP faceplate.
  - Step 3** After the SPA is properly seated, fasten the SPA in place with the captive installation screws on either side of the SPA.
- 

## Removing a SPA from a SIP

Before you remove a SPA from the SIP, read this important information about SPA cable clips that will help to make removing the SPA easier. The SPA accessory kit is shipped with three different versions of cable clips, as shown in [Figure 6-3](#).

Follow the procedure to install one set of the shipped cable clips to the already installed plastic pull tab on the SPA. [Figure 6-2](#) shows the SPA with the plastic pull tab installed.

**Figure 6-2** Installed Cisco ASR 1000 Series SPA Plastic Pull Tab

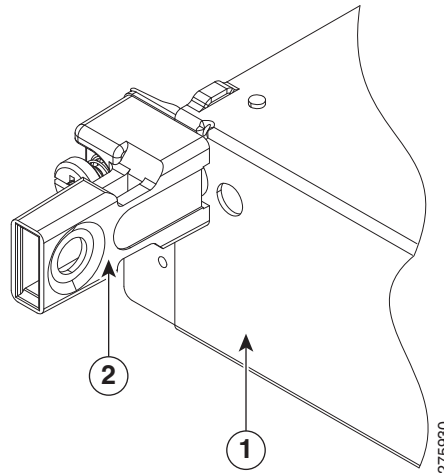

1	SPA	2	Plastic pull tab (shipped with the SPA)
---	-----	---	---

To install a cable clip to each side of the SPA, follow these steps:

- Step 1** Select one set of cable clips from the SPA accessory kit. [Figure 6-3](#) shows the cable clip options.

Figure 6-3 Cisco ASR 1000 Series Cable Clip Versions for SPA Removal

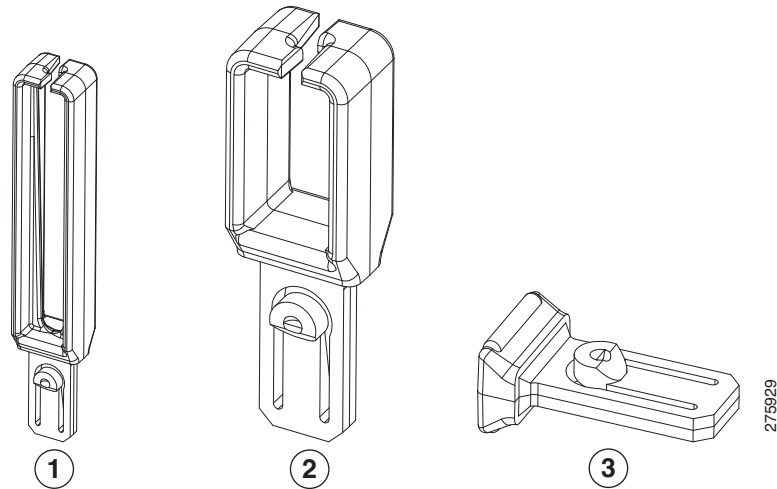

1	Long clip	3	Small cap clip
2	Short clip		



**Note** The cable clip shown in the following graphics is only an example of one option. Select the cable clip version most useful in your environment.

**Step 2** Hold and position the cable clip with the narrow edge vertically lined up with the open end of the plastic pull tab that protrudes from the SPA, as shown in Figure 6-4.

Figure 6-4 Installing a Cisco ASR 1000 Series Cable Clip into the SPA Plastic Pull Tab

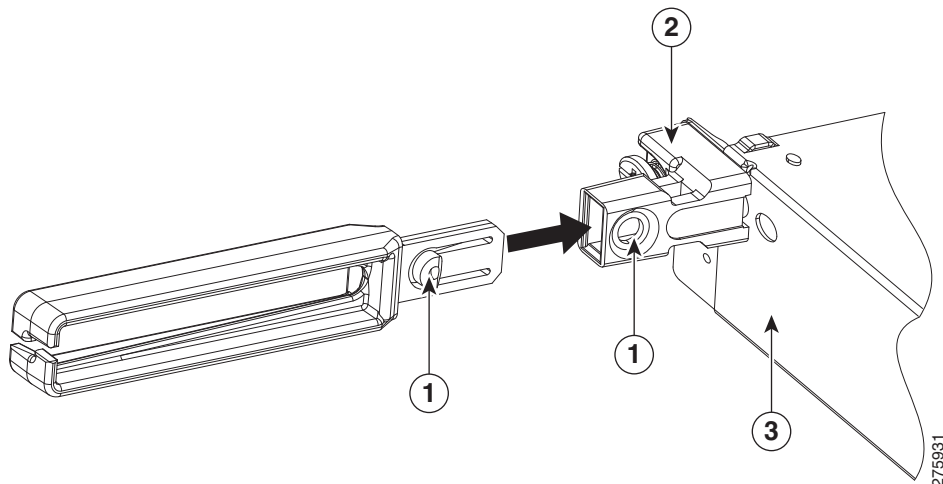

1	Portion of the cable clip that locks into position	3	SPA
2	SPA plastic pull tab		





**Note** The cable clip is designed to easily snap into position.

- Step 3** Install another cable clip to the other side of the SPA. [Figure 6-5](#) shows the cable clip fully inserted into the plastic pull tab on a SPA.

**Figure 6-5** Cisco ASR 1000 Series SPA with a Cable Clip Installed

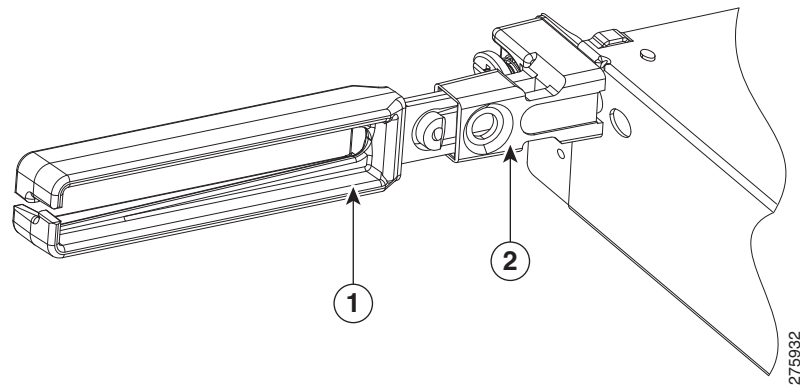

<b>1</b>	Cable clip	<b>2</b>	SPA plastic pull tab
----------	------------	----------	----------------------

- Step 4** You have installed the cable clip to the SPA. Go to the next step to remove the SPA.
- Step 5** If attached, remove any cables from the SPA.
- Step 6** To remove the SPA from the SIP, unfasten the captive installation screws on either side of the SPA. [Figure 6-6](#) illustrates how to remove a SPA in a SIP.

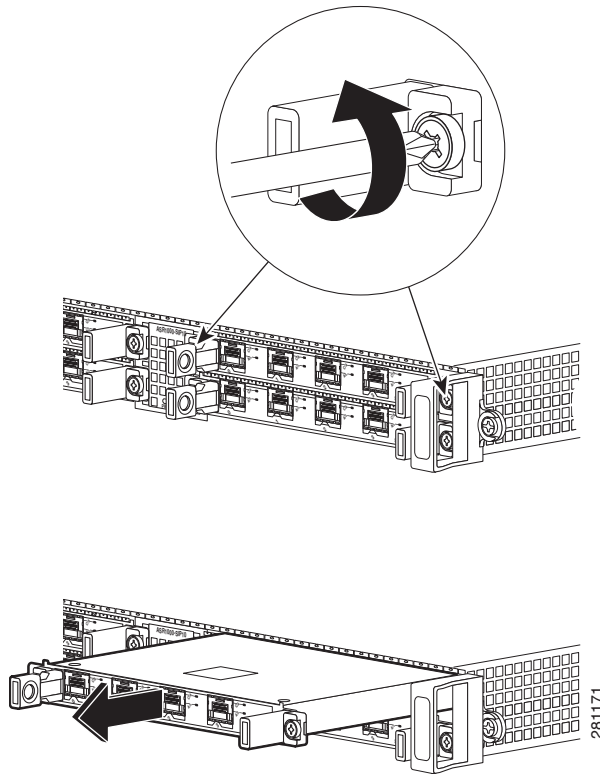
**Figure 6-6 SPA Removal**

This completes the procedure for removing a SPA from the SIP.

## Online Insertion and Removal

Cisco ASR 1000 Series Router SIPs and SPAs support online insertion and removal (OIR). SPAs can be inserted or removed independently from the SIP. OIR of a SIP with installed SPAs is also supported.

For more information about performing OIR, refer to the [“Preparing for Online Removal of a SIP” section on page 5-2](#).

## Optical Device Maintenance

Any contamination of the fiber connection can cause failure of the component or failure of the whole system. A particle that partially or completely blocks the core generates strong back reflections, which can cause instability in the laser system. Inspection, cleaning, and reinspection are critical steps to take before making fiber-optic connections.

## Cleaning Optical Devices

See the *Inspection and Cleaning Procedures for Fiber-Optic Connections* and the *Compressed Air Cleaning Issues for Fiber-Optic Connections* documents for information on cleaning optical devices.

## Checking the Installation

This section describes the procedures you can use to verify the SIP and SPA installation, and includes information on the following topics:

- [Verifying the Installation, page 6-7](#)
- [Using show Commands to Verify the SIP and SPA Status, page 6-8](#)
- [Using show Commands to Display SPA Information, page 6-9](#)

## Verifying the Installation

This section describes how to verify the SIP and SPA installation by observing the SIP LED states, SPA LED states, and the information displayed on the console terminal.

When the system has reinitialized all interfaces, the SIP STATUS LED should be green (on) and the SPA STATUS LEDs should be green (on). The port LEDs (C/A and A/L) may be green (on), depending on your connections and configuration. The console screen also displays a message as the system discovers each interface during reinitialization.

Use the following procedure to verify that a SIP and SPA are installed correctly:

- Step 1** Observe the console display messages and verify that the system discovers the SIP, while the system reinitializes each interface, as follows:
- When a new SPA is inserted into the system, the default configuration will be used for the associated interfaces.
  - As a SIP is initialized, the STATUS LED will first be amber, indicating that power is on, but the SIP is being configured. When the SIP is active, the STATUS LED will illuminate green.
  - SPAs will follow the same sequence once the SIP has completed its initialization. The SPA STATUS LEDs will illuminate amber, turning to green when the SPAs become active.
  - When the SIP and SPA STATUS LEDs are green, all associated interfaces are configurable.



**Note** Refer to the *Cisco 7600 Series Router SIP, SSC, and SPA Software Configuration Guide* for configuration instructions.

- If a SIP or SPA is replaced with a module of the same type (as in an OIR or hardware swap), the previous configuration will be reinstated when the SIP or SPA becomes active.
- If a SIP or SPA has not been previously installed in the same slot or subslot, then the configuration for all associated interfaces will be empty.



**Note** New interfaces are not available until you configure them.

- Step 2** If the SIPs and SPAs have not become active within three minutes, refer to the system console messages as follows:
- If a SIP or SPA is undergoing a field-programmable device (FPD) upgrade, then console messages will indicate that the FPD process has been initiated. The upgrade process might take several minutes. Use the **show upgrade fpd progress** command to obtain information about the FPD process. SIPs or SPAs that undergo an FPD upgrade will automatically be rebooted. Return to [Step 1](#).
  - If there is no indication that an FPD upgrade is under way, see [Chapter 7, “Troubleshooting the Installation.”](#)
- 

## Using show Commands to Verify the SIP and SPA Status

The following procedure uses **show** commands to verify that the new SPAs are configured and operating correctly.

- Step 1** Use the **show running-config** command to display the system configuration. Verify that the configuration includes the new SPA interfaces.
- Step 2** Display all of the current SPAs and a summary of their status using the **show hw-module subslot all oir** command.
- Step 3** Display information about the installed SIPs using the **show diag** command.
- Step 4** Use the **show hw-module subslot all fpd** command to verify the FPD version information of the SPAs installed in the system.



**Note** If a SPA does not meet the minimum FPD version required, it will be updated automatically. If the update fails, the failing SPA will be powered down and an error message will be reported on the system console.

---

For more information about FPD upgrades, refer to the “Upgrading Field-Programmable Devices” chapter of the *Cisco 7600 Series Router SIP, SSC, and SPA Software Configuration Guide*.

- Step 5** Use the **show version** command to obtain a few details on the installed SIPs and interfaces.
-

## Using show Commands to Display SPA Information

Table 6-1 describes the **show** commands you can use to display SPA information.

**Table 6-1** *show Commands to Display SPA Information*

Command	Type of Information Provided
<b>show controllers</b> <i>type slot/subslot/port</i>	Network link status, register contents, and controller chip errors.
<b>show diag</b>	SPA type in that slot, number of ports, hardware revision, part number, and EEPROM contents.
<b>show hw-module subslot all fpd</b>	FPD version information of SPAs in the system.
<b>show hw-module subslot all oir</b>	The operational status of all SPAs in the system.
<b>show interfaces</b> <i>type slot/subslot/port</i>	Line status and data link protocol status for a particular SPA port. Statistics about data traffic sent and received by the port.
<b>show platform</b>	Information about the router. Provides operational status of a SIP or SPA.
<b>show running-config</b>	The router's running configuration and interfaces available in the system.
<b>show version</b>	Cisco IOS software version, names and sources of configuration files, and boot images.

## SPA Blank Filler Plates

SPA blank filler plates are available to fill an unused SPA subslot.

When a SPA subslot is not in use, a SPA blank filler plate must be installed in the empty subslot to allow the router or switch to conform to electromagnetic interference (EMI) emissions requirements and to allow proper airflow across the SPAs. If you plan to install a new SPA in a subslot that is not in use, you must first remove the SPA blank filler plate.

# SPA Cable Management Brackets

SPAs are shipped with an accessory kit that includes cable management brackets. [Figure 6-7](#) shows cable management brackets installed in a SPA, as well as cable routing.

**Figure 6-7** SPA Cable Management Brackets

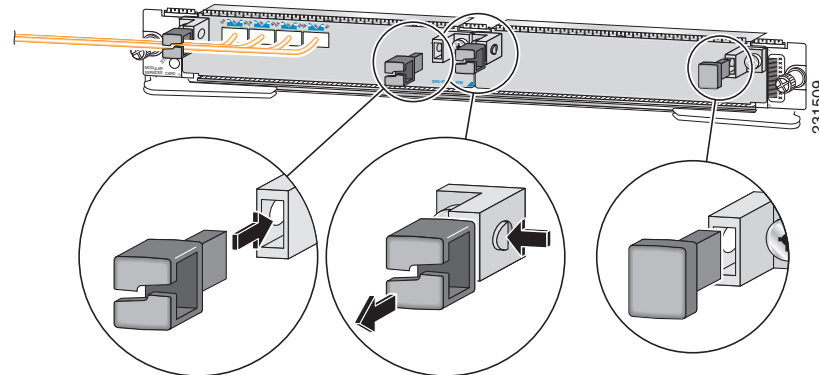

To install cable management brackets on a SPA, perform the following steps:

- 
- Step 1** Screw the two pull assemblies into both sides of the SPA.
  - Step 2** Insert the cable management bracket into the slot.
  - Step 3** To remove the cable management bracket, depress the button on the bracket and pull it out.
- 



**Note** Blank filler plugs are provided if no cable management brackets are installed.

---



## Troubleshooting the Installation

---

This chapter describes how to troubleshoot the installation of SIPs and SPAs on the Cisco ASR 1000 Series Aggregation Services Routers. This chapter contains the following sections:

- [Troubleshooting the Hardware, page 7-1](#)
- [Using debug Commands, page 7-17](#)
- [Packing a SPA for Shipment, page 7-17](#)
- [Packing a SIP for Shipment, page 7-20](#)

For additional troubleshooting information, also refer to the [Cisco ASR 1000 Series Aggregation Services Routers SIP and SPA Software Configuration Guide](#).

## Troubleshooting the Hardware

This section describes troubleshooting the installation of the SIPs and SPAs. Possible problems, observations and comments, and solutions are indicated for the following troubleshooting symptoms:

- [SIP is Deactivated, page 7-2](#)
- [SIP Transitions Repeatedly from On to Off, page 7-3](#)
- [Troubleshooting the Cisco WebEx Node and SPA-DSP for ASR 1000 Series Hardware, page 7-3](#)
- [Reformatting the Hard Disk Drive on the Cisco WebEx Node SPA, page 7-11](#)
- [Troubleshooting the 1-Port 10-Gigabit Ethernet LAN/WAN-PHY SPA for ASR 1000 Series Hardware, page 7-14](#)

## SIP is Deactivated

Table 7-1 describes the possible problems and solutions for a deactivated SIP.

**Table 7-1** Possible Problems and Solutions for a Deactivated SIP

SIP Is Deactivated		
Possible Problem	Observations and Comments	Solutions
SPA is not fully seated in the SIP	Output of the <b>show diag slot</b> command SPA STATUS LED is off	Follow this procedure: <ol style="list-style-type: none"> <li>1. Remove the SPA from the SIP.</li> <li>2. Inspect the SIP and the SPA. Verify there are no bent pins or parts and that there is nothing lodged in the two devices that could prevent a good connection.</li> <li>3. Insert the SPA in the SIP by sliding the SPA all the way into the SIP until the SPA is firmly seated in the SPA interface connector. When fully seated in the SIP, the SPA might be slightly behind the SIP faceplate.</li> </ol>
SPA DSP is out of service	Output of the <b>show hw-module subslot all oir</b> command indicates 'out of service' as Operational state for a SPA-DSP. SPA STATUS LED is off	Refer <a href="#">Table 7-3</a> for solutions and details regarding the hardware-based out-of-service states.
SPA is not supported on the SIP	Error message indicating the SPA is not supported Output of the <b>show diag slot</b> command SIP STATUS LED is off	Install a SPA supported on the SIP.
SPA is not at the minimum hardware revision level	Error message indicating the SPA is not at the minimum FPGA revision level Output of the <b>show hw-module subslot fpd</b> command Output of the <b>show diag slot</b> command SPA STATUS LED is off	Follow the FPD upgrade process to update the FPGA. For more information about performing FPD upgrades, refer to the "Upgrading Field-Programmable Devices" chapter in the <i>Cisco 7600 Series Router SIP, SSC, and SPA Software Configuration Guide</i> .
SPA is misconfigured		Refer to the configuration section of the SPA installation and configuration guide. Also, refer to the Cisco IOS software configuration documentation listed in the <a href="#">"Related Documentation" section on page xv</a> .



## SIP Transitions Repeatedly from On to Off

Table 7-2 describes the possible problems and solutions when a SIP is transitioning from on to off state.

**Table 7-2** Possible Problems and Solutions for Symptom of SIP Transitions

Possible Problem	Observations and Comments	Solutions
SIP is booting up; this is normal operation	SIP STATUS LED alternates green, amber, or off	Wait 30 seconds until the boot process completes and the STATUS LED stays on.
SIP does not go beyond the bootup stage	SIP STATUS LED transitions continue and alternates green, amber, or off	Follow the recommended action for the displayed error message.

## Troubleshooting the Cisco WebEx Node and SPA-DSP for ASR 1000 Series Hardware

This section describes some of the possible hardware problems that can occur with the Cisco WebEx Node for ASR 1000 Series (also called the Cisco WebEx Node SPA) hardware and DSP SPA for Cisco ASR 1000 Series. It includes the following problems:

- [Cisco WebEx Node SPA and SPA-DSP is in Out-of-Service State, page 7-3](#)
- [Cisco WebEx Node SPA Has Issued Hardware Error Messages, page 7-7](#)
- [Hard Disk Drive Errors on the Cisco WebEx Node SPA, page 7-8](#)
- [Collecting the show tech-support Output from the Cisco WebEx Node SPA Console, page 7-10](#)

### Cisco WebEx Node SPA and SPA-DSP is in Out-of-Service State

Both hardware and software problems can cause “out of service” states on the Cisco WebEx Node SPA and SPA-DSP.

To verify the out-of-service reason for the Cisco WebEx Node SPA or a SPA-DSP, use the **show hw-module subslot all oir** command as shown in the following example:

```
Router# show hw-module subslot all oir
Module           Model                Operational Status
-----
subslot 0/0      SPA-2X1GE-V2         ok
subslot 0/1      SPA-DSP               out of service (failed too many time)
subslot 1/1      SPA-WMA-K9            out of service (failed too many time)
```

Table 7-3 describes the possible problems and solutions for hardware-based out-of-service states. For more information about other software-based out-of-service states, refer to the troubleshooting chapter for the Cisco WebEx Node SPA or SPA-DSP in the *Cisco ASR 1000 Series Aggregation Services Routers SIP and SPA Software Configuration Guide*.

**Table 7-3** Possible Problems and Solutions for Hardware-Based Out-of-Service States on the Cisco WebEx Node SPA and SPA-DSP

Possible Problem	Observations and Comments	Solutions
SPA is not inserted correctly.	<p>The <b>show hw-module subslot all oir</b> command displays a “failed too many time” reason code for the out of service operational status.</p> <p>Other than a SPA installation problem, other possible reasons for a HW-INIT-TIMEOUT include corruption of the power controller (ADM1066) on the SPA or corruption of the Complex Programmable Logic Device (CPLD) image during an FPD upgrade.</p>	<ol style="list-style-type: none"> <li>1. Verify the installation of the SPA and attempt to reseat it in the SIP.</li> <li>2. If reinstallation of the SPA does not correct the problem, run the <b>show logging</b> command to look for other error messages that might indicate the reason for the failure (a HW_INIT_TIMEOUT is most common).</li> <li>3. Check for physical connector damage, such as a bent pin on the SPA.</li> </ol>
<p>The FPD image was corrupted for some of the following possible reasons:</p> <ul style="list-style-type: none"> <li>• SPA was removed during an FPD upgrade</li> <li>• A reload of the router occurred during an FPD upgrade.</li> <li>• A power failure occurred on the router during an FPD upgrade.</li> </ul>	<p>The <b>show hw-module subslot all oir</b> command displays a “failed too many time” reason code for the out of service operational status and the <b>show logging</b> command shows a HW-INIT-TIMEOUT failure.</p> <p>The following is an example of a HW-INIT-TIMEOUT message:</p> <pre>*Mar 3 23:27:05.903: %SPA_OIR-6-ONLINECARD: SPA (SPA-WMA-K9) online in subslot 1/1 *Mar 3 23:27:16.488: %SPA_OIR-3-HW_INIT_TIMEOUT: subslot 1/0 *Mar 3 23:27:21.488: %SPA_OIR-3-RECOVERY_RELOAD: subslot 1/0: Attempting recovery by reloading SPA *Mar 3 23:27:21.489: %SPA_OIR-6-OFFLINECARD: SPA (SPA-WMA-K9) offline in subslot 1/0</pre>	<ol style="list-style-type: none"> <li>1. Enter the <b>upgrade hw-module subslot fpd bundled</b> command to start recovery of the FPD upgrade.  If the problem was due to an FPD image corruption problem, then the SPA should boot normally after the upgrade is complete.</li> <li>2. If the FPD upgrade completes successfully but you still have an error, then the SPA probably has a hardware problem.</li> </ol>

**Table 7-3** Possible Problems and Solutions for Hardware-Based Out-of-Service States on the Cisco WebEx Node SPA and SPA-DSP (continued)

Possible Problem	Observations and Comments	Solutions
Temperature or voltage sensors have values that are not in the range of safe operation for the Cisco WebEx Node SPA and SPA-DSP.	<ul style="list-style-type: none"> <li>The <b>show hw-module subslot all oir</b> command displays an “Environmental limits exceeded” reason code.</li> <li>The <b>show hw-module subslot sensors</b> command displays the actual values for the temperature and voltage on the Cisco WebEx Node SPA, as shown in the following example:</li> </ul> <pre>Router# show hw-module subslot 0/0 sensors SPA-WMA-K9[0/0] temperature sensor 0, reading: 31C SPA-WMA-K9[0/0] temperature sensor 1, reading: 36C SPA-WMA-K9[0/0] temperature sensor 2, reading: 48C SPA-WMA-K9[0/0] temperature sensor 3, reading: 51C SPA-WMA-K9[0/0] temperature sensor 4, reading: 57C SPA-WMA-K9[0/0] temperature sensor 5, reading: 32C SPA-WMA-K9[0/0] nominal: 3.300V, reading: 3.257V SPA-WMA-K9[0/0] nominal: 2.500V, reading: 2.454V SPA-WMA-K9[0/0] nominal: 5.000V, reading: 5.038V SPA-WMA-K9[0/0] nominal: 1.200V, reading: 1.195V SPA-WMA-K9[0/0] nominal: 1.100V, reading: 1.097V SPA-WMA-K9[0/0] nominal: 1.000V, reading: 0.998V SPA-WMA-K9[0/0] nominal: 0.900V, reading: 0.892V SPA-WMA-K9[0/0] nominal: 1.800V, reading: 1.785V</pre>	<ol style="list-style-type: none"> <li>Enter the <b>show logging   include TEMP_SHUTDOWN</b> command and look for a temperature shutdown error message.  The following is an example of an error message due to excessive temperature:  *Jan 27 17:46:22.285: %SPA-0-TEMP_SHUTDOWN: SIP1/1: SPA-WMA-K9[1/1] temperature too high on sensor 2. (90C) SPA has been shut down.</li> </ol> <p><b>Tip</b> If you do not find a temperature shutdown error message, it’s possible that the logging buffer has overflowed from too many warning messages. Enter the <b>show logging   include TEMP_WARNING</b> command to confirm.</p> <ol style="list-style-type: none"> <li>If you find a temperature error message, then verify that the fan within the power supply is working correctly.  Refer to the “Troubleshooting the Cooling Subsystem” section of the “Troubleshooting Initial Startup Problems” chapter in the <i>Cisco ASR 1000 Series Aggregation Services Router Hardware Installation Guide</i>.</li> <li>If no temperature error message is found, enter the <b>show logging   include VOLT_SHUTDOWN</b> command to find a voltage shutdown error message.  If an error messages indicates a voltage problem, then the SIP could be providing an unstable voltage to the SPA, or there might be a hardware problem on the Cisco WebEx Node SPA itself.  Try installing the SPA into another SIP and see if the problem continues. If the problem still occurs, then there is a voltage problem on the Cisco WebEx Node SPA.</li> </ol>

**Table 7-3** Possible Problems and Solutions for Hardware-Based Out-of-Service States on the Cisco WebEx Node SPA and SPA-DSP (continued)

Possible Problem	Observations and Comments	Solutions
Temperature or voltage sensors have values that are not in the range of safe operation for the Cisco WebEx Node SPA and SPA-DSP.	<p>Execute the <b>show hw-module subslot sensors</b> command for a SPA-DSP to display the actual values for the temperature and voltage on the SPA-DSP, as shown in the following example:</p> <pre>Router# show hw-module subslot 0/2 sensors SPA-DSP[0/2] temperature sensor 0, reading: 43C SPA-DSP[0/2] temperature sensor 1, reading: 38C SPA-DSP[0/2] temperature sensor 2, reading: 44C SPA-DSP[0/2] nominal: 3.300V, reading: 3.275V SPA-DSP[0/2] nominal: 2.500V, reading: 2.517V SPA-DSP[0/2] nominal: 1.800V, reading: 1.786V SPA-DSP[0/2] nominal: 3.300V, reading: 3.293V SPA-DSP[0/2] nominal: 1.200V, reading: 1.194V SPA-DSP[0/2] nominal: 1.000V, reading: 0.993V</pre> <p>Execute the <b>show hw-module subslot sensors limit</b> command for a SPA-DSP to compare the warning, critical, and shutdown temperatures and voltage values with actual values. The <b>show hw-module subslot sensors limit</b> command not only displays the actual voltage and temperature values, but also provides the temperature and voltage limit values for the warning, critical, and shutdown states for a sensor.</p> <pre>Router# show hw-module subslot 0/2 sensors limits Temperature sensors for SPA-DSP[0/2]: Sensor Reading Low Warning Critical Shutdown 0 43C -5C 70C 85C 91C 1 38C -5C 62C 77C 83C 2 44C -5C 67C 82C 88C Voltage sensors for SPA-DSP[0/2]: Nominal Reading LowShut LowWarn HighWarn HighShut 3.300V 3.278V 2.970V 3.069V 3.531V 3.630V 2.500V 2.517V 2.250V 2.325V 2.675V 2.750V 1.800V 1.785V 1.620V 1.674V 1.926V 1.980V 3.300V 3.293V 2.970V 3.069V 3.531V 3.630V 1.200V 1.194V 1.080V 1.116V 1.284V 1.320V 1.000V 0.993V 0.900V 0.930V 1.070V 1.100V</pre>	<p><b>Tip</b> Use the WebEx Node solutions mentioned above for SPA-DSP.</p>

## Cisco WebEx Node SPA Has Issued Hardware Error Messages

There are several different error messages for the Cisco WebEx Node SPA that might appear in the output of the **show logging** command. [Table 7-4](#) provides an example of error messages of the SPA\_CPU\_ERR type.

For more information about other system error messages for the Cisco WebEx Node SPA, refer to the [System Messages for Cisco IOS XE](#) document.

**Table 7-4** SPA\_CPU\_ERR Messages on the Cisco WebEx Node SPA

Possible Problem	Observations and Comments	Solutions
Hardware problem on the Cisco WebEx Node SPA.	<p>The <b>show logging</b> command shows a SPA_CPU_ERR message for the SPA_SRVCS_ENGINE facility, as shown in the following example:</p> <pre>*Mar 24 23:52:06.527: %SPA_SRVCS_ENGINE-3-SPA_CPU_ERR: SIP0/1: SPA-WMA-K9[0/1]: SPA CPU HW errors: Octeon L2D ECC double bit (core 4): fadr: 0x23e86, syn0: 0x0, syn1: 0xe7c00 *Mar 24 23:52:06.527: %SPA_SRVCS_ENGINE-3-HW_ERR: SIP0/1: SPA-WMA-K9[0/1]: A Hardware device error was detected by SPA CPU, trying to recover the SPA by reload.</pre>	<ol style="list-style-type: none"> <li>1. Look up the error message in the Error Message Decoder tool or in the <a href="#">System Messages for Cisco IOS XE</a> document.</li> <li>2. Record the message exactly as it appears on the console.</li> <li>3. Collect the output from the <b>show tech-support</b> command on the Cisco WebEx Node SPA console and contact Cisco technical support to create a Return Materials Authorization (RMA) case.</li> </ol> <p>For information about running the show tech-support command on the Cisco WebEx Node SPA console, see the <a href="#">“Collecting the show tech-support Output from the Cisco WebEx Node SPA Console”</a> section on page 7-10.</p>
DSP SPA: A hardware device error was detected	<p>DSP firmware is a software that performs all DSP services. DSP firmware is downloaded from SIP to the SPA-DSP. If DSP firmware is not downloaded to SPA-DSP, the following error message is displayed on console: “DSP SPA: A hardware device error was detected”.</p>	<p>Reload the SPA-DSP using the <b>hw-module slot/subslot reload</b> command from privilege exec command mode.</p>

## Hard Disk Drive Errors on the Cisco WebEx Node SPA

The Cisco WebEx Node SPA has a hard disk drive (HDD) used by the Cisco WebEx Node application. It stores logs and provides a cache for meeting data.

Table 7-5 describes the possible problems and solutions associated with the HDD that the Cisco ASR Series 1000 Routers can detect during a boot of the Cisco WebEx Node SPA.

**Table 7-5** Possible HDD Problems and Solutions on the Cisco WebEx Node SPA

Possible Problem	Observations and Comments	Solutions
File System Check Error	<p>The system routinely checks for file system integrity during a SPA boot, or when the system detects a previous unclean shutdown operation of SPA.</p> <p>Most of the time errors in the file system can be corrected automatically during SPA bootup, but there are cases that manual intervention is required to fix file system errors.</p> <p>When this type of error occurs, the following syslog message is logged on IOS:</p> <pre>*Apr 14 22:42:17.415: %SPA_SE1-3-DISK_CHECK_ERROR: SIP0/1: SPA-WMA-K9[0/1]: Disk file system check error detected, manual execution of disk checking operation will be required to correct this problem. The SPA will continue operating with reduced disk space.</pre>	<ol style="list-style-type: none"> <li>1. Access the Cisco WebEx Node SPA system console using the <b>hw-module subslot service-engine session</b> command, as shown in the following example: <pre>Router# hw-module subslot 0/1 service-engine session MontaVista(R) Linux(R) Carrier Grade Edition 5.0 (custom) Linux/mips64 2.6.21_mvlcge500-octeon-mips64_octeon_v2_be Vegas Shell -- CGE 5.0 Version Copyright (c) 1985-2008 by Cisco Systems, Inc. All rights reserved.</pre> </li> <li>2. From the SPA console, run the <b>fsck disk VEGAS</b> shell command, and respond to the prompts as shown in the following example: <p><b>Timesaver</b> The <b>fsck disk</b> command supports an option to respond “yes” to all prompts to allow you to run the <b>fsck disk</b> automatically without any manual response.</p> <pre>service-spa# fsck disk Running file system check on /dev/sda2 partition ... e2fsck 1.40 (29-Jun-2007) APPLICATION contains a file system with errors, check forced. Pass 1: Checking inodes, blocks, and sizes Inode 7 has illegal block(s). Clear&lt;y&gt;? <b>yes</b></pre> </li> </ol>

Table 7-5 Possible HDD Problems and Solutions on the Cisco WebEx Node SPA (continued)

		<pre> Illegal block #24716 (1515870810) in inode 7. CLEARED. Illegal block #24717 (1515870810) in inode 7. CLEARED. Illegal block #24718 (1515870810) in inode 7. CLEARED. Illegal block #24719 (1515870810) in inode 7. CLEARED. Illegal block #24720 (1515870810) in inode 7. CLEARED. Illegal block #24721 (1515870810) in inode 7. CLEARED. Illegal block #24722 (1515870810) in inode 7. CLEARED. Illegal block #24723 (1515870810) in inode 7. CLEARED. Illegal block #24724 (1515870810) in inode 7. CLEARED. Illegal block #24725 (1515870810) in inode 7. CLEARED. Illegal block #24726 (1515870810) in inode 7. CLEARED. Too many illegal blocks in inode 7. Clear inode&lt;y&gt;? <b>yes</b>  Restarting e2fsck from the beginning... Resize inode not valid.  Recreate&lt;y&gt;? <b>yes</b>  APPLICATION contains a file system with errors, check forced. Pass 1: Checking inodes, blocks, and sizes Pass 2: Checking directory structure Pass 3: Checking directory connectivity Pass 4: Checking reference counts Pass 5: Checking group summary information Free blocks count wrong for group #0 (28103, counted=28104). Fix&lt;y&gt;? yes Free blocks count wrong (242639, counted=242640). Fix&lt;y&gt;? yes  APPLICATION: ***** FILE SYSTEM WAS MODIFIED ***** APPLICATION: 12/125696 files (0.0% non-contiguous), 8367/251007 blocks  <b>3.</b>Exit the SPA console using the <b>exit</b> command, as shown in the following example:  service-spa# <b>exit</b> Router#  <b>4.</b> Reload the Cisco WebEx Node SPA using the <b>hw-module subslot reload</b> command. </pre>
--	--	--

**Table 7-5** Possible HDD Problems and Solutions on the Cisco WebEx Node SPA (continued)

File System Mounting Error	<p>The following message appears on the console:</p> <pre>*Apr 15 23:14:31.721: %SPA_SE1-3-DISK_MOUNT_ERROR: SIP0/0: SPA-WMA-K9[0/0]: Disk mount error detected, manual execution of disk checking operation might be required to correct this problem. The SPA will continue operating with reduced disk space.</pre>	Follow the recommended steps for the <a href="#">File System Check Error</a> .
HDD loosens during handling of the SPA	<p>The system cannot detect the disk and displays the following message on the console:</p> <pre>*Apr 15 23:00:06.664: %SPA_SE1-3-DISK_NOT_PRESENT: SIP0/0: SPA-WMA-K9[0/0]: Cannot detect the presence of disk drive on the SPA. Please check for loose cable connection to the drive. The SPA will continue operating without the disk.</pre>	<ol style="list-style-type: none"> <li>1. Check for a loose cable connection to the HDD on the SPA, and reconnect the cable.</li> <li>2. Collect the output from the <b>show tech-support</b> command on the Cisco WebEx Node SPA console and contact Cisco technical support.</li> </ol> <p>For information about running the show tech-support command on the Cisco WebEx Node SPA console, see the <a href="#">“Collecting the show tech-support Output from the Cisco WebEx Node SPA Console”</a> section on page 7-10.</p>
Other HDD hardware errors	<p>For other hardware errors on the HDD, you might see the following message on the console:</p> <pre>*Apr 15 23:04:06.678: %SPA_SE1-3-DISK_UNKNOWN_STAT E: SIP0/0: SPA-WMA-K9[0/0]: The disk drive on the SPA doesn't seems to be on known operational state. Please check for loose cable connection to the drive. The SPA will continue operating without the disk.</pre>	<ol style="list-style-type: none"> <li>1. Check for a loose cable connection to the HDD on the SPA, and reconnect the cable.</li> <li>2. Collect the output from the <b>show tech-support</b> command on the Cisco WebEx Node SPA console and contact Cisco technical support.</li> </ol> <p>For information about running the show tech-support command on the Cisco WebEx Node SPA console, see the <a href="#">“Collecting the show tech-support Output from the Cisco WebEx Node SPA Console”</a> section on page 7-10.</p>

## Collecting the show tech-support Output from the Cisco WebEx Node SPA Console

When reporting a problem to Cisco technical support, you should first obtain the output of the **show tech-support** command from the WebEx Node SPA console. The following example show how to run the command and redirect the output to a file on a TFTP server:

```
service-spa# show tech-support > tftp://tftpboot_server/show-tech-output-2009-06-71.txt
Trying to connect to tftp server.....
!!!!!!!!!!!!!!!!!!!!!!!!!!!!!!!!!!!!!!!!!!!!!!!!!!!!!!!!!!!!!!!!!!!!!!!!!!!!!!!!!!!!!!!!!!!!!!!!!!!!!!!!!!!!!!!!!!!!
!!!!!!!!!!
!!!!!!!!!!!!!!!!!!!!!!!!!!!!!!!!!!!!!!!!!!!!!!!!!!!!!!!!!!!!!!!!!!!!!!!!!!!!!!!!!!!!!!!!!!!!!!!!!!!!!!!!!!!!!!!!!!!!
!!!!!!!!!!
```



```

!!!!!!!!!!!!!!!!!!!!!!!!!!!!!!!!!!!!!!!!!!!!!!!!!!!!!!!!!!!!!!!!!!!!!!!!!!!!!!!!!!!!!!!!!!!!!!!!!!!!!!!!!!!!!!!!!!!!!!!!
!!!!!!!!!!
!!!!!!!!!!
TFTP put operation was successful

 153782 bytes copied
service-spa#

```

## Reformatting the Hard Disk Drive on the Cisco WebEx Node SPA



### Note

This procedure is only recommended if a manual file system repair does not fix file system errors.

### Prerequisites

Before you can format the hard disk on a Cisco WebEx Node SPA, the disk must be unmounted not in use. If you attempt to format the disk while the disk is mounted, you will receive a warning as shown in the following example:

```

service-spa# format disk
Do you want to format [y/n]: y
%WARNING: cannot perform disk formatting operation as there are partitions mounted and
being used by the system.

```

To prepare the disk for formatting, complete the following steps:

- 
- Step 1** Access the SIP console using the **request platform software console attach** command as shown in the following example:
- ```

Router# request platform software console attach 0/0
#
# Connecting to the SPA console on 0/0.
# Enter Control-C to exit the console connection.
#
Router>

```
- Step 2** Enter the **enable** command and run the **test hw-module subslot bay disk-repair set** command as shown in the following example:
- ```

Router> enable
Router# test hw-module subslot 0 disk-repair set
WARNING: This command is not intended for production use
and should only be used under the supervision of
Cisco Systems technical support personnel.

SPA is set to not mount disk filesystem on next reboot. Please reload to take effect!

Router#

```
- Step 3** Return to the RP console by entering **Control-C** and then reload the SPA using the **hw-module subslot reload** command as shown in the following example:
- ```

<Control-C>
Router# hw-module subslot 0/0 reload

```
- Step 4** Confirm if the following message appears on the router console:

```
*Apr 7 08:23:49.974: %SPA_SE1-3-SKIPPED_DISK_MOUNT: SIP0/0: SPA-WMA-K9[0/0]: Disk mounting
operation has been skipped for manual disk repair operation. Please follow the procedures
on hardware configuration guide on how to enter into service engine console to continue
with the disk repair operation.
```

**Step 5** Access the Cisco WebEx Node SPA's VEGAS shell console using the **hw-module subslot service-engine session** command as shown in the following example:

```
Router# hw-module subslot 0/0 service-engine session

MontaVista(R) Linux(R) Carrier Grade Edition 5.0 (custom)
Linux/mips64 2.6.21_mvlcge500-octeon-mips64_octeon_v2_be

Vegas Shell -- CGE 5.0 Version
Copyright (c) 1985-2008 by Cisco Systems, Inc.
All rights reserved.
```

**Step 6** Run the **format disk** command and confirm the operation as shown in the following example:

```
service-spa# format disk
Do you want to format [y/n]: y
Drive /dev/sda already has 4 partitions. Need to delete them to re-create new ones!

Delete partition 4 ...

Delete partition 3 ...

Delete partition 2 ...

Delete partition 1 ...

Creating partitions in /dev/sda ....

Creating APPLICATION partition on /dev/sda1 ...
mke2fs 1.40 (29-Jun-2007)
Filesystem label=APPLICATION
OS type: Linux
Block size=4096 (log=2)
Fragment size=4096 (log=2)
125696 inodes, 251007 blocks
12550 blocks (5.00%) reserved for the super user
First data block=0
Maximum filesystem blocks=260046848
8 block groups
32768 blocks per group, 32768 fragments per group
15712 inodes per group
Superblock backups stored on blocks:
    32768, 98304, 163840, 229376

Writing inode tables: done
Creating journal (4096 blocks): done
Writing superblocks and filesystem accounting information: done

This filesystem will be automatically checked every 34 mounts or
180 days, whichever comes first. Use tune2fs -c or -i to override.

Creating CONFIG partition on /dev/sda2 ...
mke2fs 1.40 (29-Jun-2007)
Filesystem label=CONFIG
OS type: Linux
```

```

Block size=1024 (log=0)
Fragment size=1024 (log=0)
26208 inodes, 104420 blocks
5221 blocks (5.00%) reserved for the super user
First data block=1
Maximum filesystem blocks=67371008
13 block groups
8192 blocks per group, 8192 fragments per group
2016 inodes per group
Superblock backups stored on blocks:
    8193, 24577, 40961, 57345, 73729

Writing inode tables: done
Creating journal (4096 blocks): done
Writing superblocks and filesystem accounting information: done

This filesystem will be automatically checked every 20 mounts or
180 days, whichever comes first.  Use tune2fs -c or -i to override.

Creating DATA partition on /dev/sda4 ...
mke2fs 1.40 (29-Jun-2007)
Filesystem label=DATA
OS type: Linux
Block size=4096 (log=2)
Fragment size=4096 (log=2)
30146560 inodes, 60269855 blocks
3013492 blocks (5.00%) reserved for the super user
First data block=0
Maximum filesystem blocks=0
1840 block groups
32768 blocks per group, 32768 fragments per group
16384 inodes per group
Superblock backups stored on blocks:
    32768, 98304, 163840, 229376, 294912, 819200, 884736, 1605632, 2654208,
    4096000, 7962624, 11239424, 20480000, 23887872

Writing inode tables: done
Creating journal (32768 blocks): done
Writing superblocks and filesystem accounting information: done

This filesystem will be automatically checked every 37 mounts or
180 days, whichever comes first.  Use tune2fs -c or -i to override.
Creating SWAP space in /dev/sda3 ...
Setting up swap space version 1, size = 2056315904 bytes

*****
Format operation result: SUCCESSFUL
*****
service-spa#

```

**Tip**

The SPA-DSP has neither a CPU nor a hard disk as compared to the WebEx Node SPA. Hence, there are no CPU error messages or hard disk error messages for a SPA-DSP.

## Troubleshooting the 1-Port 10-Gigabit Ethernet LAN/WAN-PHY SPA for ASR 1000 Series Hardware

This section describes some of the hardware problems that may occur with the 1-Port 10-Gigabit Ethernet LAN/WAN-PHY SPA for also called the SPA-1X-10GE-WL-V2 SPA.

Table 7-6 describes the possible problems and solutions for hardware-based out-of-service states.

**Table 7-6** Possible Reasons and Solutions for Hardware-Based Errors on the 1-Port 10-Gigabit Ethernet LAN/WAN-PHY SPA

| Possible Problem                    | Observations and Comments                                                                                                                                                                                                                                                                                                                                                                                                                                                                                                                                                                                                                                                                                                                                                                                         | Solutions                                                                                                                                                                                                                                                                                                                                                                                                                                                           |
|-------------------------------------|-------------------------------------------------------------------------------------------------------------------------------------------------------------------------------------------------------------------------------------------------------------------------------------------------------------------------------------------------------------------------------------------------------------------------------------------------------------------------------------------------------------------------------------------------------------------------------------------------------------------------------------------------------------------------------------------------------------------------------------------------------------------------------------------------------------------|---------------------------------------------------------------------------------------------------------------------------------------------------------------------------------------------------------------------------------------------------------------------------------------------------------------------------------------------------------------------------------------------------------------------------------------------------------------------|
| SPA Hardware initialization timeout | <p>The SPA initialization is performed by SIP. If the initialization of hardware has timed out, a HW-INIT-TIMEOUT message is displayed on the console.</p> <p>The <b>show hw-module subslot all oir</b> command displays a “failed too many times” reason code for the out-of-service operational status and the <b>show logging</b> command shows a HW-INIT-TIMEOUT failure.</p> <p>The following is an example of a HW-INIT-TIMEOUT message:</p> <pre>*Mar 3 23:27:05.903: %SPA_OIR-6-ONLINECARD: SPA (SPA-1X10GE-WL-V2) online in subslot 1/1 *Mar 3 23:27:16.488: %SPA_OIR-3-HW_INIT_TIMEOUT: subslot 1/0 *Mar 3 23:27:21.488: %SPA_OIR-3-RECOVERY_RELOAD: subslot 1/0: Attempting recovery by reloading SPA *Mar 3 23:27:21.489: %SPA_OIR-6-OFFLINECARD: SPA (SPA-1X10GE-WL-V2) offline in subslot 1/0</pre> | <ol style="list-style-type: none"> <li>1. Reload or reseal (reinsert) the SPA.</li> <li>2. Enter the <b>upgrade hw-module subslot fpd bundled</b> command to start the recovery of the FPD upgrade.<br/><br/>If the problem was due to an FPD image corruption, the SPA should boot normally after the upgrade is complete.</li> <li>3. If the FPD upgrade completes successfully, but you still have an error, the SPA probably has a hardware problem.</li> </ol> |

# Feature Change to CPU-Usage show Command

To display the current CPU-Usage for a FRU, the **show platform software process slot *slot* monitor cycles *cycles* interval *interval* lines *lines*** command is used from the console. The way this command is run on a FRU, is changed from Cisco IOS XE Release 3.4.0s.

## Old Behavior

If *lines* is specified in the **show platform software process slot *slot* monitor cycles *cycles* interval *interval* lines *lines*** command, the results generated and displayed did not reflect accurate CPU utilization at the time. This was because the command was executed as many cycles as specified one cycle at a time.

The following example shows the output of the **show platform software process slot *slot* monitor cycles *cycles* interval *interval* lines *lines*** command.

This command produced inaccurate CPU usage details as illustrated in the following example:

```
Router# show platform software process slot r0 monitor cycles 4 interval 3 lines 5
top - 18:26:00 up 4 min, 0 users, load average: 1.89, 1.97, 0.86
Tasks: 133 total, 2 running, 131 sleeping, 0 stopped, 0 zombie
Cpu(s): 34.4%us, 32.3%sy, 0.0%ni, 27.4%id, 3.2%wa, 0.5%hi, 2.2%si, 0.0%st
Mem: 3874984k total, 1553444k used, 2321540k free, 102904k buffers
Swap: 0k total, 0k used, 0k free, 963120k cached

top - 18:26:03 up 4 min, 0 users, load average: 1.89, 1.97, 0.86
Tasks: 133 total, 3 running, 130 sleeping, 0 stopped, 0 zombie
Cpu(s): 34.0%us, 31.9%sy, 0.0%ni, 28.3%id, 3.2%wa, 0.5%hi, 2.2%si, 0.0%st
Mem: 3874984k total, 1553444k used, 2321540k free, 102904k buffers
Swap: 0k total, 0k used, 0k free, 963120k cached

top - 18:26:07 up 4 min, 0 users, load average: 1.74, 1.94, 0.86
Tasks: 133 total, 3 running, 130 sleeping, 0 stopped, 0 zombie
Cpu(s): 33.6%us, 31.5%sy, 0.0%ni, 29.2%id, 3.1%wa, 0.5%hi, 2.2%si, 0.0%st
Mem: 3874984k total, 1553452k used, 2321532k free, 102904k buffers
Swap: 0k total, 0k used, 0k free, 963120k cached

top - 18:26:10 up 4 min, 0 users, load average: 1.60, 1.91, 0.85
Tasks: 133 total, 2 running, 131 sleeping, 0 stopped, 0 zombie
Cpu(s): 33.2%us, 31.1%sy, 0.0%ni, 30.0%id, 3.1%wa, 0.5%hi, 2.2%si, 0.0%st
Mem: 3874984k total, 1553452k used, 2321532k free, 102904k buffers
Swap: 0k total, 0k used, 0k free, 963124k cached
```

## New Behavior

The **show platform software process slot *slot* monitor cycles *cycles* interval *interval*** command produced accurate CPU usage details, if executed without the **lines *number-of-lines*** parameters. The **show** command, if executed without the **lines *number-of-lines*** keywords is executed in batch-mode.



### Note

To display accurate CPU usage details, execute the **show platform software process slot *slot* monitor cycles *cycles* interval *interval*** command without the **lines *number-of-lines*** keyword or use the **top** command **top -s -b -n iterations -d interval** from Linux shell.

The following example provides accurate CPU usage details (note the value fluctuation in the first column) when 'lines' is not specified. When the command is executed with the lines specified, it still has the old behavior where the first column will not be consistent with the CPU usage on the FRU.

The following example provides accurate CPU usage details with no line count specified:

```
Router# show platform software process slot r0 monitor cycles 4 interval 3
top - 18:26:20 up 4 min, 0 users, load average: 1.35, 1.84, 0.84
Tasks: 132 total, 3 running, 129 sleeping, 0 stopped, 0 zombie
Cpu(s): 32.2%us, 30.1%sy, 0.0%ni, 32.2%id, 3.0%wa, 0.4%hi, 2.1%si, 0.0%st
Mem: 3874984k total, 1553072k used, 2321912k free, 102904k buffers
Swap: 0k total, 0k used, 0k free, 963140k cached

  PID USER      PR  NI  VIRT  RES  SHR  S  %CPU  %MEM    TIME+  COMMAND
 2776 root        20   0  2648 1152  884  R   2.0   0.0   0:00.01 top
14538 root        20   0  4468 2828 1308  S   2.0   0.1   0:00.79 droputil.sh
   1 root        20   0  2156  644  556  S   0.0   0.0   0:01.34 init
   2 root        15  -5     0   0     0  S   0.0   0.0   0:00.00 kthreadd
   3 root        15  -5     0   0     0  S   0.0   0.0   0:00.08 ksoftirqd/0
   4 root        RT  -5     0   0     0  S   0.0   0.0   0:00.00 watchdog/0
   5 root        15  -5     0   0     0  S   0.0   0.0   0:00.03 events/0
   6 root        15  -5     0   0     0  S   0.0   0.0   0:00.02 khelper
   9 root        15  -5     0   0     0  S   0.0   0.0   0:00.00 netns
  62 root        15  -5     0   0     0  S   0.0   0.0   0:00.00 kblockd/0
  70 root        15  -5     0   0     0  S   0.0   0.0   0:00.00 ata/0
  71 root        15  -5     0   0     0  S   0.0   0.0   0:00.00 ata_aux
  77 root        15  -5     0   0     0  S   0.0   0.0   0:00.00 khubd
  80 root        15  -5     0   0     0  S   0.0   0.0   0:00.00 kseriod
 125 root        20   0     0   0     0  S   0.0   0.0   0:00.00 pdflush
```

The following example provides CPU usage details with line count specified:

```
Router# show platform software process slot r0 monitor cycles 10 interval 5 lines 10 | inc
%id
Cpu(s): 20.6%us, 21.5%sy, 0.0%ni, 53.3%id, 1.6%wa, 0.5%hi, 2.4%si, 0.0%st
Cpu(s): 20.4%us, 21.3%sy, 0.0%ni, 53.7%id, 1.6%wa, 0.5%hi, 2.4%si, 0.0%st
Cpu(s): 20.2%us, 21.1%sy, 0.0%ni, 54.2%id, 1.6%wa, 0.5%hi, 2.4%si, 0.0%st
Cpu(s): 20.0%us, 20.9%sy, 0.0%ni, 54.7%id, 1.6%wa, 0.5%hi, 2.3%si, 0.0%st
Cpu(s): 19.8%us, 20.7%sy, 0.0%ni, 55.1%id, 1.6%wa, 0.5%hi, 2.3%si, 0.0%st
Cpu(s): 19.8%us, 20.9%sy, 0.0%ni, 54.8%id, 1.6%wa, 0.5%hi, 2.4%si, 0.0%st
Cpu(s): 19.6%us, 21.0%sy, 0.0%ni, 54.7%id, 1.5%wa, 0.5%hi, 2.6%si, 0.0%st
Cpu(s): 19.5%us, 20.8%sy, 0.0%ni, 55.2%id, 1.5%wa, 0.5%hi, 2.5%si, 0.0%st
Cpu(s): 19.3%us, 20.6%sy, 0.0%ni, 55.6%id, 1.5%wa, 0.5%hi, 2.5%si, 0.0%st
Cpu(s): 19.1%us, 20.4%sy, 0.0%ni, 56.0%id, 1.5%wa, 0.5%hi, 2.5%si, 0.0%st
```

## Using debug Commands

The **debug hw-module subslot** command is intended for use by Cisco technical support personnel. For more information about the **debug hw-module subslot** command, see the *Cisco 7600 Series Router SIP, SSC, and SPA Software Configuration Guide*.

**Caution**

Because debugging output is assigned high priority in the CPU process, it can render the system unusable. For this reason, use **debug** commands only to troubleshoot specific problems or during troubleshooting sessions with Cisco technical support staff. Moreover, it is best to use **debug** commands during periods of lower network traffic and fewer users. Debugging during these periods decreases the likelihood that increased **debug** command processing overhead will affect system use.

## Packing a SPA for Shipment

This section provides step-by-step instructions for packing a SPA for shipment. Before beginning this procedure, you should have the following original Cisco packaging materials:

- Clamshell inner container
- Foam cushion (2)
- Exterior carton

**Note**

For information on removing a SPA, see the [“SPA Installation and Removal” section on page 6-2](#).

**Caution**

The Cisco original packaging is to be used for the shipment of all SPAs and cable management brackets. Failure to properly use Cisco packaging can result in damage or loss of a product.

**Caution**

During this procedure, wear grounding wrist straps to avoid ESD damage to the card.

See [Preventing Electrostatic Discharge Damage, page 4-8](#) for information about preventing ESD.

**Note**

These instructions assume that the SPA and cable management brackets have been removed from the router according to the recommended procedures specified in this guide.

To pack a SPA for shipment, see [Figure 7-1](#) and perform the following steps:

**Step 1** Open the clamshell container and place the SPA into the appropriate cavity.

**Caution**

Always handle the SPA by the carrier edges and handle; never touch the SPA components or connector pins.

**Step 2** Close the clamshell container.

- Step 3** Check that the clamshell container is fully closed. Apply tape or a label closure over the opening to ensure that the container stays closed during shipping.
  - Step 4** Place one foam cushion in the bottom of the exterior carton.
  - Step 5** Place the clamshell container into the carton on top of the foam.
  - Step 6** Place the second foam cushion on top of the clamshell.
  - Step 7** Close the exterior carton.
  - Step 8** Apply tape over the exterior carton flap to ensure that the carton stays closed during shipping.
-



Figure 7-1 Packing a SPA for Shipment

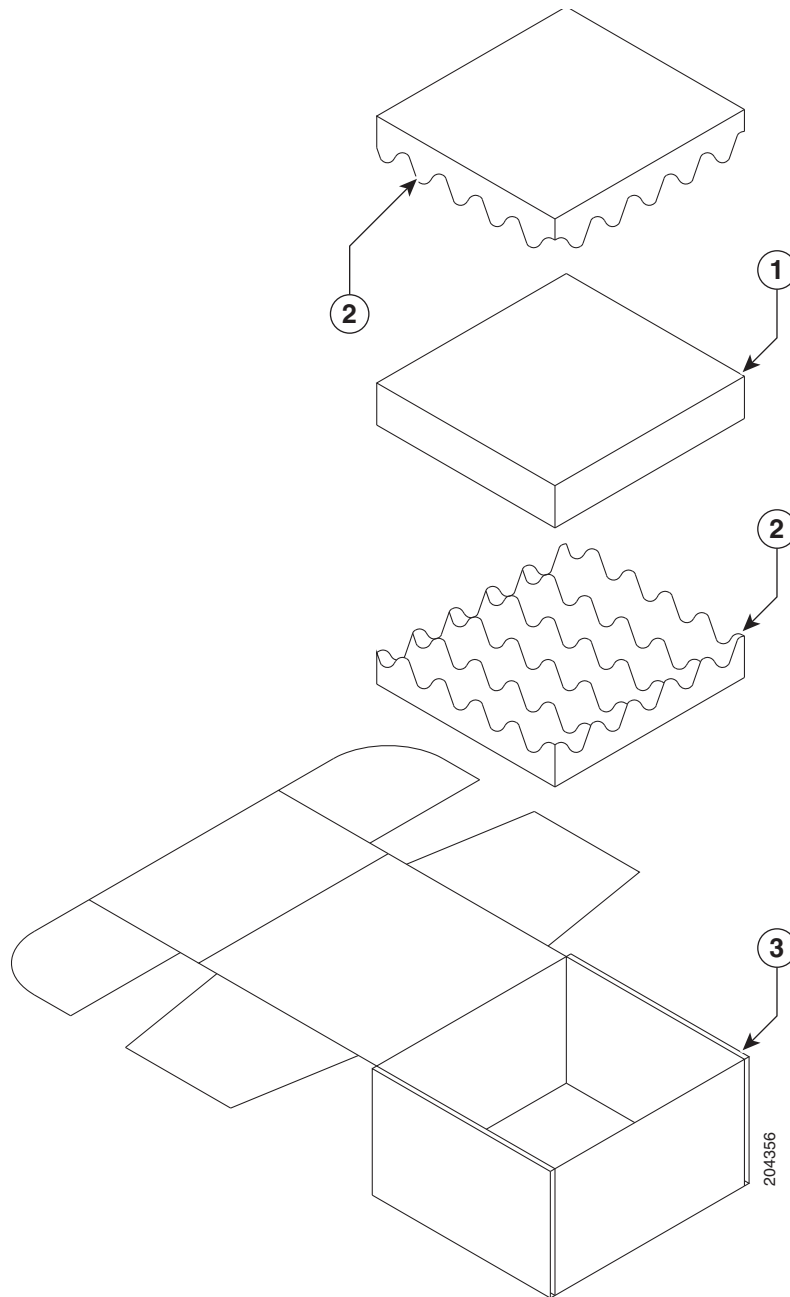

|          |                 |          |              |
|----------|-----------------|----------|--------------|
| <b>1</b> | Clamshell       | <b>2</b> | Cushion foam |
| <b>3</b> | Exterior carton |          |              |

# Packing a SIP for Shipment

This section provides step-by-step instructions for packing a SIP for shipment. Before beginning this procedure, you should have the following original Cisco packaging materials:

- Static shielding bag
- Corrugated spacer
- Bottom support
- Smaller inner carton
- Two foam packing cushions
- Larger exterior carton

**Note**

For information on removing a SIP, see the [“SIP Installation and Removal”](#) section on page 5-9.

**Caution**

The Cisco original packaging is to be used for the shipment of all SIPs. Failure to properly use Cisco packaging can result in damage or loss of a product.

**Caution**

During this procedure, wear grounding wrist straps to avoid ESD damage to the card.

See [Preventing Electrostatic Discharge Damage, page 4-8](#) for information about preventing ESD.

**Note**

These instructions assume that the SIP has been removed from the router according to the recommended procedures specified in this guide.

To pack a SIP for shipment, see [Figure 7-2](#), and perform the following steps:

- Step 1** Insert the SIP into the static shielding bag. (Not shown in diagram.)
- Step 2** Place the bottom support into the smaller inner carton.
- Step 3** Place the bagged SIP onto the bottom support.
- Step 4** Place the corrugated spacer on top of the bagged SIP.
- Step 5** Close the smaller inner carton and tape the sides closed.
- Step 6** Place the sealed smaller inner carton containing the SIP into the two foam packing cushions (the carton only fits one way).
- Step 7** Place the sealed smaller inner carton and packing cushions into the larger exterior carton, and seal the larger exterior carton with tape for shipment.

Figure 7-2 Packing a SIP for Shipment

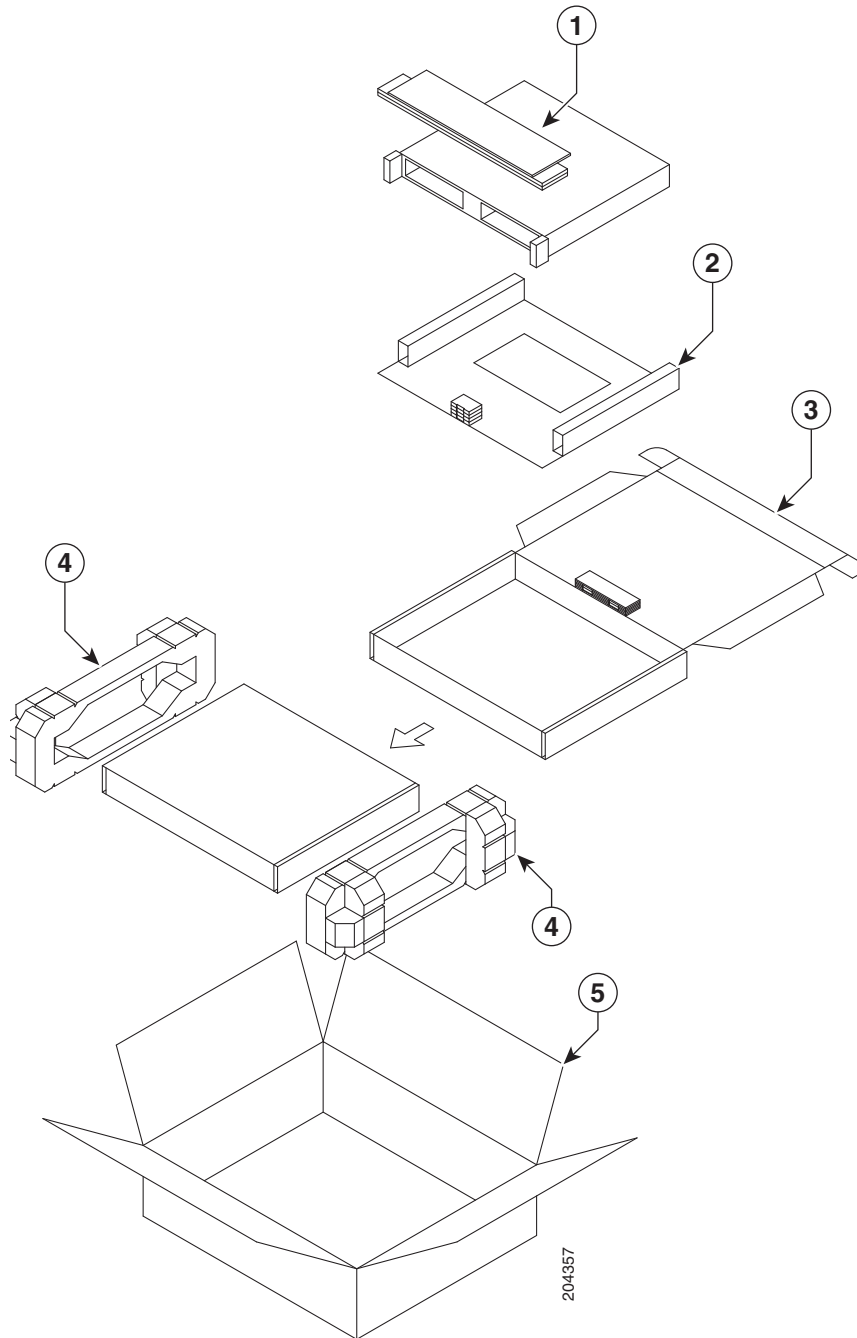

|   |                   |   |                                 |
|---|-------------------|---|---------------------------------|
| 1 | Corrugated spacer | 2 | Bottom support for inner carton |
| 3 | Inner carton      | 4 | Foam packing cushions           |
| 5 | Exterior carton   |   |                                 |

