



# Cisco HyperFlex HX220c M4 Node

CISCO SYSTEMS  
170 WEST TASMAN DR  
SAN JOSE, CA, 95134  
[WWW.CISCO.COM](http://WWW.CISCO.COM)

## PUBLICATION HISTORY

REV A.1      FEBRUARY 17, 2016

<b>OVERVIEW</b> . . . . .	<b>3</b>
<b>DETAILED VIEWS</b> . . . . .	<b>4</b>
Chassis Front View . . . . .	4
Chassis Rear View . . . . .	5
<b>BASE HX220c M4 STANDARD CAPABILITIES and FEATURES</b> . . . . .	<b>6</b>
<b>CONFIGURING the HX220c M4</b> . . . . .	<b>9</b>
STEP 1 VERIFY SKU . . . . .	10
STEP 2 SELECT CPU(s) . . . . .	11
STEP 3 SELECT MEMORY . . . . .	13
STEP 4 SELECT DRIVE CONTROLLER . . . . .	16
SAS HBA (internal HDD/SSD/JBOD support) . . . . .	16
STEP 5 SELECT HARD DISK DRIVES (HDDs) or SOLID STATE DRIVES (SSDs) . . . . .	17
STEP 6 SELECT PCIe OPTION CARD(s) . . . . .	18
STEP 7 ORDER POWER SUPPLIES . . . . .	19
STEP 8 SELECT AC POWER CORD(s) . . . . .	20
STEP 9 ORDER TOOL-LESS RAIL KIT AND OPTIONAL REVERSIBLE CABLE MANAGEMENT ARM . . . . .	23
STEP 10 ORDER A TRUSTED PLATFORM MODULE (OPTIONAL) . . . . .	24
STEP 11 ORDER CISCO FLEXIBLE FLASH SD CARD MODULE . . . . .	25
STEP 12 SELECT OPERATING SYSTEM AND VALUE-ADDED SOFTWARE . . . . .	26
STEP 13 SELECT SERVICE and SUPPORT LEVEL . . . . .	27
<b>OPTIONAL STEP - ORDER RACK(s)</b> . . . . .	<b>31</b>
<b>OPTIONAL STEP - ORDER PDU</b> . . . . .	<b>32</b>
<b>SUPPLEMENTAL MATERIAL</b> . . . . .	<b>33</b>
Hyperconverged Systems . . . . .	33
Chassis . . . . .	34
Block Diagram . . . . .	35
CPUs and DIMMs . . . . .	36
Physical Layout . . . . .	36
Memory Population Rules . . . . .	37
DIMM Population Order . . . . .	38
Serial Port Details . . . . .	39
Upgrade and Servicing-Related Parts . . . . .	40
Motherboard Lithium Battery . . . . .	41
Thermal Grease (with syringe applicator) for CPU to Heatsink Seal . . . . .	41
Air Baffle Replacement Kit . . . . .	41
RACKS . . . . .	42
PDUs . . . . .	44
KVM CABLE . . . . .	45
<b>TECHNICAL SPECIFICATIONS</b> . . . . .	<b>46</b>
Dimensions and Weight . . . . .	46
Power Specifications . . . . .	47
Environmental Specifications . . . . .	48
Compliance Requirements . . . . .	49

## OVERVIEW

Cisco HyperFlex™ Systems unlock the full potential of hyperconvergence. The systems are based on an end-to-end software-defined infrastructure, combining software-defined computing in the form of Cisco Unified Computing System (Cisco UCS) servers; software-defined storage with the powerful Cisco HX Data Platform and software-defined networking with the Cisco UCS fabric that will integrate smoothly with Cisco Application Centric Infrastructure (Cisco ACI™). Together with a single point of connectivity and hardware management, these technologies deliver a preintegrated and adaptable cluster that is ready to provide a unified pool of resources to power applications as your business needs dictate.

The Cisco HyperFlex HX220c M4 Node is shown in [Figure 1](#).

Figure 1 Cisco HyperFlex HX220c M4 Node

Front View



Rear View



# DETAILED VIEWS

## Chassis Front View

Figure 2 shows the front view of the Cisco HyperFlex HX220c M4 Node (with front bezel removed).

Figure 2 Chassis Front View

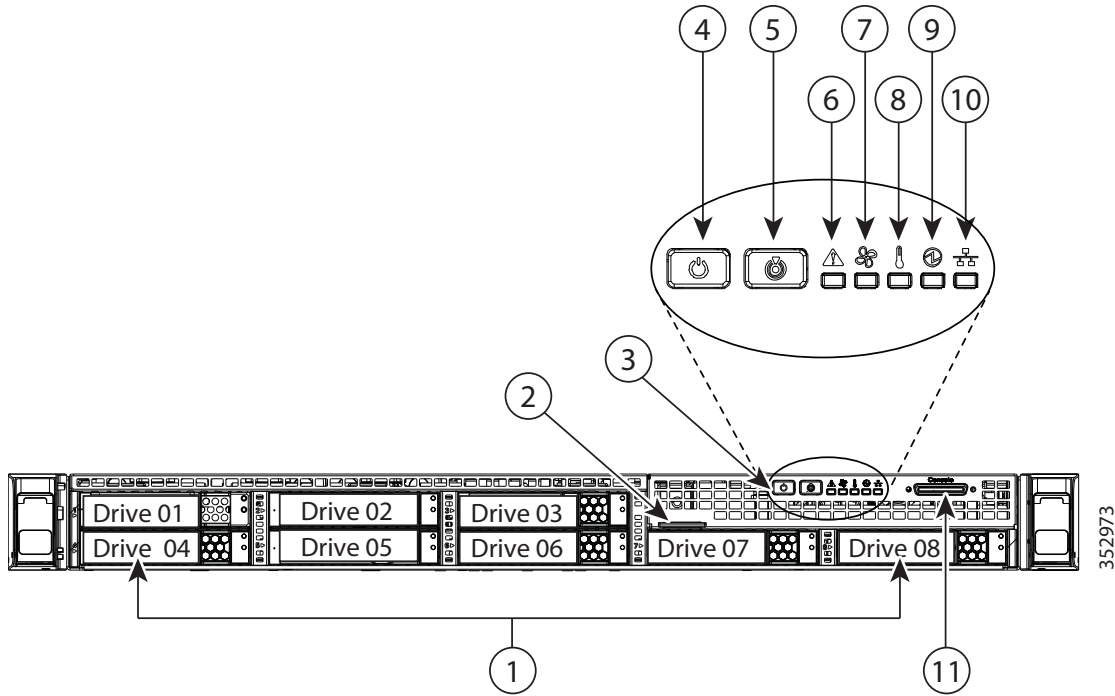

1	Drives <ul style="list-style-type: none"> <li>■ Up to 6 x 1.2 TB SAS HDDs (for data) Drives 03 through 08</li> <li>■ 1 x 120 GB SATA SSD drive (for SDS logs) Drive 01</li> <li>■ 1 x 480 GB SATA SSD drive (for caching) Drive 02</li> </ul>	7	Fan status LED
2	Pull-out asset tag	8	Temperature status LED
3	Operations panel buttons and LEDs	9	Power supply status LED
4	Power button/Power status LED	10	Network link activity LED
5	Unit identification button/LED	11	KVM connector (used with KVM cable that provides two USB 2.0, one VGA, and one serial connector) <sup>1</sup>
6	System status LED	—	—

Notes . . .

1. For more information about the KVM cable connection, see [KVM CABLE, page 45](#)

## Chassis Rear View

Figure 3 shows the external features of the rear panel.

Figure 3 Chassis Rear View

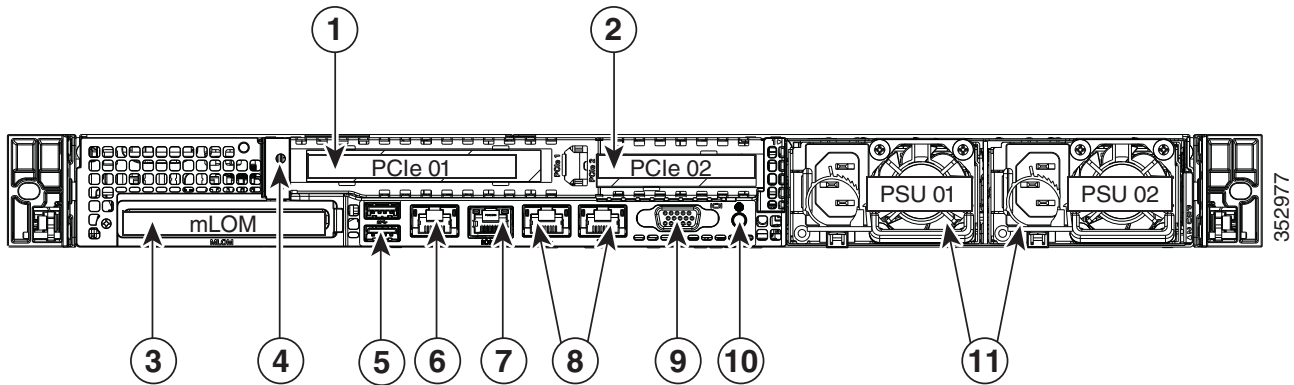

1	PCIe riser 1/slot 1	7	Serial port (RJ-45 connector) <sup>1</sup>
2	PCIe riser 2/slot 2	8	Two embedded (on the motherboard) Intel i350 GbE Ethernet controller ports (LAN1, LAN2)
3	Modular LAN-on-motherboard (mLOM) card slot	9	VGA video port (DB-15)
4	Grounding-lug hole (for DC power supplies)	10	Rear unit identification button/LED
5	USB 3.0 ports (two)	11	Power supplies (up to two, redundant as 1+1)
6	1-Gb Ethernet dedicated management port	—	—

Notes . . .

1. For details of the serial port pinout, see [Serial Port Details, page 39](#).

## BASE HX220c M4 STANDARD CAPABILITIES and FEATURES

*Table 1* lists the capabilities and features of the base HX220c M4 Node. Details about how to configure the system for a particular feature or capability (for example, number of processors, disk drives, or amount of memory) are provided in *CONFIGURING the HX220c M4, page 9*.

Table 1 Capabilities and Features

Capability/Feature	Description
Chassis	One rack unit (1RU) chassis
CPU	Two Intel® Xeon E5-2600 v3 series processor family CPUs
Chipset	Intel® C610 series chipset
Memory	24 slots for registered ECC DIMMs (RDIMMs)
Multi-bit Error Protection	Supports multi-bit error protection.
Embedded NIC	Two embedded (on the motherboard) Intel i350 GbE ports, supporting the following: <ul style="list-style-type: none"> <li>■ Pre-Execution Boot (PXE boot)</li> <li>■ iSCSI boot</li> <li>■ Checksum and segmentation offload</li> <li>■ NIC teaming</li> </ul>
Expansion slots	Riser 1 (controlled by CPU 1): <ul style="list-style-type: none"> <li>■ One full-height profile, 3/4-length slot with x24 connector and x16 lane</li> </ul> Riser 2 (controlled by CPU 2): <ul style="list-style-type: none"> <li>■ One half-height profile, half-length slot with x24 connector and x16 lane</li> </ul> Dedicated disk controller slot (see <i>Figure 6 on page 34</i> ) <ul style="list-style-type: none"> <li>■ An internal slot is reserved for use by the Cisco 12 Gbps Modular SAS HBA.</li> </ul>
Internal storage devices	Drives are installed into front-panel drive bays that provide hot-pluggable access. <ul style="list-style-type: none"> <li>■ Small Form Factor (SFF) drives. <ul style="list-style-type: none"> <li>• Up to 6 1.2 TB SAS HDDs (for data)</li> <li>• One 120 GB SATA SSD (for SDS logs)</li> <li>• One 480 GB SATA SSD (for caching)</li> </ul> </li> </ul>
Cisco Flexible Flash drives	The system supports two internal 64 GB Cisco Flexible Flash drives (SD cards). The SD cards are mirrored to each other and are used for booting.

Table 1 Capabilities and Features *(continued)*

Capability/Feature	Description
Video	<p>The Cisco Integrated Management Controller (CIMC) provides video using the Matrox G200e video/graphics controller:</p> <ul style="list-style-type: none"> <li>■ Integrated 2D graphics core with hardware acceleration</li> <li>■ DDR2/3 memory interface supports up to 512 MB of addressable memory (8 MB is allocated by default to video memory)</li> <li>■ Supports display resolutions up to 1920 x 1200 16bpp @ 60Hz</li> <li>■ High-speed integrated 24-bit RAMDAC</li> <li>■ Single lane PCI-Express host interface running at Gen 1 speed</li> </ul>
Interfaces	<ul style="list-style-type: none"> <li>■ Rear panel <ul style="list-style-type: none"> <li>• One DB15 VGA connector</li> <li>• One RJ45 serial port connector</li> <li>• Two USB 3.0 port connectors</li> <li>• One RJ-45 10/100/1000 Ethernet management port, using Cisco Integrated Management Controller (CIMC) firmware</li> <li>• Two Intel i350 embedded (on the motherboard) GbE LOM ports</li> <li>• One flexible modular LAN on motherboard (mLOM) slot that accommodates the Cisco UCS VIC1227 VIC MLOM - Dual Port 10Gb SFP+ interface card.</li> <li>• Two PCIe 3.0 slots</li> </ul> </li> <li>■ Front panel <ul style="list-style-type: none"> <li>• One KVM console connector (supplies two USB 2.0 connectors, one VGA DB15 connector, and one serial port (RS232) RJ45 connector)</li> </ul> </li> </ul>
Storage controller	<ul style="list-style-type: none"> <li>■ Cisco 12 Gbps Modular SAS HBA with internal SAS connectivity <ul style="list-style-type: none"> <li>• Supports up to 24 internal drives (note however that this system can be configured with a maximum of 8 drives)</li> <li>• Plugs into a dedicated internal disk controller slot</li> <li>• Supports JBOD only, not RAID</li> </ul> </li> </ul>
WoL	The 1-Gb Base-T Ethernet LAN ports support the wake-on-LAN (WoL) standard.
Front Panel	A front panel controller provides status indications and control buttons
Modular LAN on Motherboard (mLOM) slot	<p>The mLOM slot accommodates the following card:</p> <ul style="list-style-type: none"> <li>■ Cisco VIC 1227 Virtual Interface Cards</li> </ul>
Power subsystem	Two 770 W (AC) hot swappable power supplies.
ACPI	This system supports the advanced configuration and power interface (ACPI) 4.0 standard.
Fans	<p>Chassis:</p> <ul style="list-style-type: none"> <li>■ Six hot-swappable fans for front-to-rear cooling</li> </ul>

Table 1 Capabilities and Features *(continued)*

Capability/Feature	Description
Integrated management processor	Baseboard Management Controller (BMC) running Cisco Integrated Management Controller (CIMC) firmware. Depending on your CIMC settings, the CIMC can be accessed through the 1-GbE dedicated management port, the 1-GbE LOM ports, or a Cisco virtual interface card (VIC).

---



## CONFIGURING the HX220c M4

For the most part, this system comes with a fixed configuration. Use these steps to see or change the configuration of the Cisco HX220c M4 Node:

- *STEP 1 VERIFY SKU, page 10*
- *STEP 2 SELECT CPU(s), page 11*
- *STEP 3 SELECT MEMORY, page 13*
- *STEP 4 SELECT DRIVE CONTROLLER, page 16*
- *STEP 5 SELECT HARD DISK DRIVES (HDDs) or SOLID STATE DRIVES (SSDs), page 17*
- *STEP 6 SELECT PCIe OPTION CARD(s), page 18*
- *STEP 7 ORDER POWER SUPPLIES, page 19*
- *STEP 8 SELECT AC POWER CORD(s), page 20*
- *STEP 9 ORDER TOOL-LESS RAIL KIT AND OPTIONAL REVERSIBLE CABLE MANAGEMENT ARM, page 23*
- *STEP 10 ORDER A TRUSTED PLATFORM MODULE (OPTIONAL), page 24*
- *STEP 11 ORDER CISCO FLEXIBLE FLASH SD CARD MODULE, page 25*
- *STEP 12 SELECT OPERATING SYSTEM AND VALUE-ADDED SOFTWARE, page 26*
- *STEP 13 SELECT SERVICE and SUPPORT LEVEL, page 27*
- *OPTIONAL STEP - ORDER RACK(s), page 31*
- *OPTIONAL STEP - ORDER PDU, page 32*

## STEP 1 VERIFY SKU

Verify the product ID (PID) from [Table 2](#).

Table 2 PID of the HX220c M4 Node

Product ID (PID)	Description
HX220C-M4S	HX220c M4 Node, with two CPUs, memory, six HDDs, two SSDs, two power supplies, two SD cards, one VIC 1227 mLOM card, no PCIe cards, and no rail kit

The HX220c M4 Node:

- Includes two power supplies, two CPUs, memory, hard disk drives (HDDs), solid-state drives (SSDs), VIC 1227 mLOM card, and SD cards
- Does not include rail kit or plug-in PCIe cards.



**NOTE:** Use the steps on the following pages to see or change the configuration of the system.

## STEP 2 SELECT CPU(s)

The standard CPU features are:

- Intel Xeon E5-2600 v3 series processor family CPUs
- Intel C610 series chipset
- Cache size of up to 40 MB

### Select CPUs

The available CPUs are listed in [Table 3](#).

Table 3 Available Intel CPUs: E5-2600 v3 Series Processor Family CPUs

Product ID (PID)	Intel Number	Clock Freq (GHz)	Power (W)	Cache Size (MB)	Cores	QPI	Highest DDR4 DIMM Clock Support (MHz) <sup>1</sup>
UCS-CPU-E52698D	E5-2698 v3	2.30	135	40	16	9.6 GT/s	2133
UCS-CPU-E52697D	E5-2697 v3	2.60	145	35	14	9.6 GT/s	2133
UCS-CPU-E52695D	E5-2695 v3	2.30	120	35	14	9.6 GT/s	2133
UCS-CPU-E52690D	E5-2690 v3	2.60	135	30	12	9.6 GT/s	2133
UCS-CPU-E52680D	E5-2680 v3	2.50	120	30	12	9.6 GT/s	2133
UCS-CPU-E52670D	E5-2670 v3	2.30	120	30	12	9.6 GT/s	2133
UCS-CPU-E52667D	E5-2667 v3	3.20	135	20	8	9.6 GT/s	2133
UCS-CPU-E52660D	E5-2660 v3	2.60	105	25	10	9.6 GT/s	2133
UCS-CPU-E52658D	E5-2658 v3	2.20	105	30	12	9.6 GT/s	2133
UCS-CPU-E52650D	E5-2650 v3	2.30	105	25	10	9.6 GT/s	2133
UCS-CPU-E52640D	E5-2640 v3	2.60	90	20	8	8.0 GT/s	1866
UCS-CPU-E52630D	E5-2630 v3	2.40	85	20	8	8.0 GT/s	1866

#### Notes . . .

1. If higher or lower speed DIMMs are selected than what is shown in the table for a given CPU, the DIMMs will be clocked at the lowest common denominator of CPU clock and DIMM clock.

## Approved Configurations

---

### (1) 2-CPU Configuration:

- Select two identical CPUs from any one of the rows of [Table 3 on page 11](#).

### Caveats

---

- You must select two identical processors.
- For optimal performance, select DIMMs with the highest clock speed for a given processor (see [Table 3 on page 11](#)). If you select DIMMs whose speeds are lower or higher than that shown in the tables, suboptimal performance will result.

## STEP 3 SELECT MEMORY

The standard memory features are:

- DIMMs
  - Clock speed: 2133 MHz
  - Ranks per DIMM: 2
  - Operational voltage: 1.2 V
  - Registered ECC DDR4 DIMMs (RDIMMs)
- Memory is organized with four memory channels per CPU, with up to three DIMMs per channel, as shown in [Figure 4](#).

Figure 4 HX220c M4 Node Memory Organization

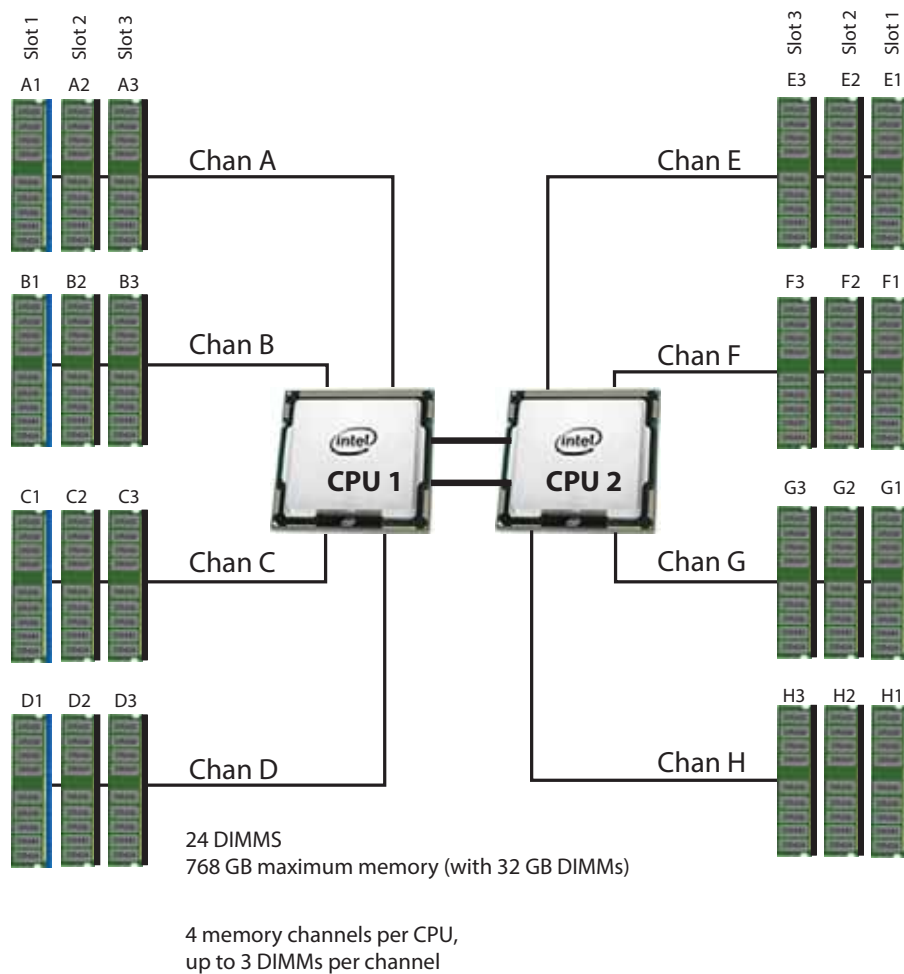

Select DIMMs

Select the desired DIMMs from [Table 4](#).

Table 4 Available DDR4 DIMMs

Product ID (PID)	PID Description	Voltage	Ranks/ DIMM
<b>DIMM Options</b>			
UCS-MR-1X322RU-A	32GB DDR4-2133-MHz RDIMM/PC4-17000/dual rank/x4	1.2 V	2
UCS-MR-1X162RU-A	16GB DDR4-2133-MHz RDIMM/PC4-17000/dual rank/x4	1.2 V	2

Approved Configurations

(1) 2-CPU configuration:

- Select either 8 or 12 identical DIMMs per CPU (16 or 24 total identical DIMMs). Refer to [Memory Population Rules, page 37](#), for more detailed information.



**NOTE:** System performance is optimized when the DIMM type and quantity are equal for both CPUs, and when all channels are filled equally across the CPUs.

Caveats

- System speed is dependent on how many DIMMs are populated per channel and the CPU DIMM speed support. See [Table 5](#) for details.

Table 5 DIMM Memory Speeds with Different CPUs

DIMM Speed	DPC	1866-MHz Capable CPU	2133-MHz Capable CPU
		RDIMM (DR)	RDIMM (DR)
2133 DIMM <sup>1</sup>	3 DPC	1600	1866 (32 GB RDIMMs and 16 GB DIMMs)
	2 DPC	1866	2133
	1 DPC	1866	2133

Notes . . .

1. 2133-MHz DIMMs are the only offered and supported DIMMs for the HX220c M4 Node.

- The HX220c M4 Node supports the following memory reliability, availability, and serviceability (RAS) modes:
  - Independent Channel Mode

- Lockstep Channel Mode
- Below are the system level RAS Mode combination limitations:
  - Mixing of Independent and Lockstep channel mode is not allowed per platform.
- DIMMs for CPU 1 and CPU 2 must always be configured identically.
- Non-ECC DIMMs are not supported.
- Pairs of DIMMs (A1/B1, A2/B2, etc) MUST be the exact same (same PID, rev, DIMM loading order)
- Cisco memory from previous generation systems (DDR3) is not compatible with this system.

For more information regarding memory, see [CPUs and DIMMs, page 36](#).

## STEP 4 SELECT DRIVE CONTROLLER

### SAS HBA (internal HDD/SSD/JBOD support)

Choose the following SAS HBA for internal drive connectivity (non-RAID):

- Cisco 12 Gbps Modular SAS HBA, which plugs into a dedicated RAID controller slot.

#### Select Controller Options

---

Select the following:

- Cisco 12 Gbps Modular SAS HBA (see [Table 6](#))

Table 6 Hardware Controller Options

Product ID (PID)	PID Description
<b>Controllers for Internal Drives</b>	
Note that the following Cisco 12Gbps Modular SAS HBA controller is factory-installed in the dedicated internal slot.	
UCSC-SAS12GHBA	Cisco 12 Gbps Modular SAS HBA <ul style="list-style-type: none"> <li>■ Supports up to 24 internal SAS HDDs and SAS/SATA SSDs (limited to 8 drives in this system)</li> <li>■ Supports JBOD mode only (no RAID functionality. Ideal for SDS (Software Defined Storage) applications. It is also ideal for environments demanding the highest IOPs (for external SSD attach), where a RAID controller can be an I/O bottleneck.</li> </ul>

#### Approved Configurations

---

- The Cisco 12 Gbps Modular SAS HBA supports up to 8 internal drives with JBOD support.



## STEP 5 SELECT HARD DISK DRIVES (HDDs) or SOLID STATE DRIVES (SSDs)

The standard disk drive features are:

- 2.5-inch small form factor
- Hot-pluggable
- Drives come mounted in sleds

### Select Drives

---

The available drives are listed in [Table 7](#).

Table 7 Available Hot-Pluggable Sled-Mounted HDDs and SSDs

Product ID (PID)	PID Description	Drive Type	Capacity
<b>HDD Data Drive</b>			
UCS-HD12TB10K12G	1.2 TB 12G SAS 10K RPM SFF HDD	SAS	1.2 TB
<b>SATA SSD Caching Drive</b>			
UCS-SD480G12S3-EP	480 GB 2.5 inch Enterprise Performance 6G SATA SSD (3X endurance)	SATA	480 GB
<b>SATA SSD SDS Logs Drive</b>			
UCS-SD120GBKS4-EV	120 GB 2.5 inch Enterprise Value 6 G SATA SSD	SATA	120 GB

### Approved Configurations

---

#### (1) Cisco 12 Gbps Modular SAS HBA

- Select the following drives:
  - Up to six 1.2 TB 12G SAS 10K RPM SFF HDD data drives (UCS-HD12TB10K12G)
  - One 480 GB 2.5 inch Enterprise Performance 6G SATA SSD caching drive (UCS-SD480G12S3-EP)
  - One 120 GB 2.5 inch Enterprise Value 6 G SATA SSD SDS logs drive (UCS-SD120GBKS4-EV)

See [SELECT DRIVE CONTROLLER, page 16](#) for more details.

### Caveats

---

- You must choose up to six HDDs and one of each SSD.

## STEP 6 SELECT PCIe OPTION CARD(s)

The standard PCIe card offerings is:

- Modular LAN on Motherboard (mLOM)

### Select PCIe Option Card

---

The available PCIe option card is listed in [Table 8](#).

**Table 8 Available PCIe Option Cards**

Product ID (PID)	PID Description	Card Height
<b>Modular LAN on Motherboard (mLOM)<sup>1</sup></b>		
UCSC-MLOM-CSC-02	Cisco UCS VIC1227 VIC MLOM - Dual Port 10Gb SFP+	N/A

Notes . . .

1. The mLOM card does not plug into any of the riser 1 or riser 2 card slots; instead, it plugs into a connector inside the chassis.

### Caveats

---

- Other considerations for the Cisco VIC 1227 card:
  - VIC 1227 supports 10G SFP+ optical and copper twinax connections
  - The VIC 1227 is supported with the following software releases: 2.0.8h and above (CIMC) and 2.2.6f (UCSM).

## STEP 7 ORDER POWER SUPPLIES

The HX220c M4 Node accommodates two 770 W AC power supplies. The power supply PIDs are shown in [Table 9](#). The link below can be used to estimate power consumption.

<http://ucspowercalc.cisco.com>

Table 9 Power Supply PIDs

Product ID (PID)	PID Description
UCSC-PSU1-770W	770 W power supply

### Approved Configurations

- This system must have two power supplies.

## STEP 8 SELECT AC POWER CORD(S)

Using [Table 10](#), select the appropriate AC power cords. You must select a minimum of zero and a maximum of two identical power cords. However, If you select the option R2XX-DMYMPWRCORD, no power cord is shipped with the HX220c Node.

Table 10 Available Power Cords

Product ID (PID)	PID Description	Images
R2XX-DMYMPWRCORD	No power cord (dummy PID to allow for a no power cord option)	Not applicable
CAB-N5K6A-NA	Power Cord, 200/240V 6A, North America	
CAB-AC-L620-C13	AC Power Cord, NEMA L6-20 - C13, 2M/6.5ft	
CAB-C13-CBN	CABASY,WIRE,JUMPER CORD, 27" L, C13/C14, 10A/250V	
CAB-C13-C14-2M	CABASY,WIRE,JUMPER CORD, PWR, 2 Meter, C13/C14,10A/250V	
CAB-C13-C14-AC	CORD,PWR,JMP,IEC60320/C14,IEC60320/C13, 3.0M	

Table 10 Available Power Cords

Product ID (PID)	PID Description	Images
CAB-250V-10A-AR	Power Cord, 250V, 10A, Argentina	
CAB-9K10A-AU	Power Cord, 250VAC 10A 3112 Plug, Australia	
CAB-250V-10A-CN	AC Power Cord - 250V, 10A - PRC	
CAB-9K10A-EU	Power Cord, 250VAC 10A CEE 7/7 Plug, EU	
SFS-250V-10A-ID	Power Cord, SFS, 250V, 10A, India	
SFS-250V-10A-IS	Power Cord, SFS, 250V, 10A, Israel	
CAB-9K10A-IT	Power Cord, 250VAC 10A CEI 23-16/VII Plug, Italy	

Table 10 Available Power Cords

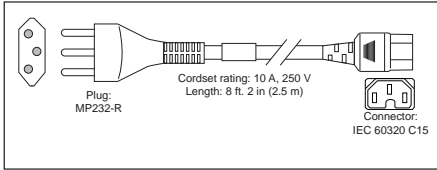
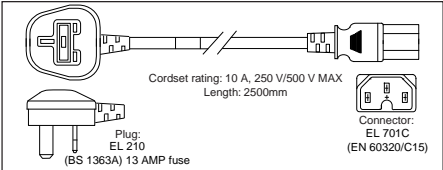
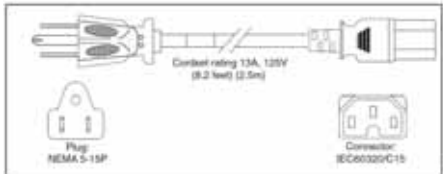
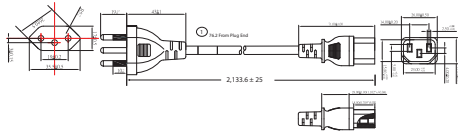
Product ID (PID)	PID Description	Images
CAB-9K10A-SW	Power Cord, 250VAC 10A MP232 Plug, Switzerland	 <p>Cordset rating: 10 A, 250 V Length: 8 ft. 2 in (2.5 m) Plug: MP232-R Connector: IEC 60320 C15</p>
CAB-9K10A-UK	Power Cord, 250VAC 10A BS1363 Plug (13 A fuse), UK	 <p>Cordset rating: 10 A, 250 V/500 V MAX Length: 2500mm Plug: EL 210 (BS 1363A) 13 AMP fuse Connector: EL 701C (EN 60320/C15)</p>
CAB-9K12A-NA	Power Cord, 125VAC 13A NEMA 5-15 Plug, North America	 <p>Cordset rating: 13A, 125V (8.2 feet) (2.5m) Plug: NEMA 5-15P Connector: IEC 60320 C15</p>
CAB-250V-10A-BR	Power Cord - 250V, 10A - Brazil	 <p>2,133.6 ± 25</p>
CAB-JPN-3PIN	Power Cord 3PIN, Japan	Image not available

## STEP 9 ORDER TOOL-LESS RAIL KIT AND OPTIONAL REVERSIBLE CABLE MANAGEMENT ARM

### Select a Tool-Less Rail Kit

---

Select a tool-less rail kit from [Table 11](#).

Table 11 Tool-Less Rail Kit Options

Product ID (PID)	PID Description
UCSC-RAILF-M4	Friction Rail Kit
UCSC-RAILB-M4	Ball Bearing Rail Kit for

### Select an Optional Reversible Cable Management Arm

---

The reversible cable management arm mounts on either the right or left slide rails at the rear of the HX220c Node and is used for cable management. Use [Table 12](#) to order a cable management arm.

Table 12 Cable Management Arm

Product ID (PID)	PID Description
UCSC-CMAF-M4	Reversible CMA for tool-less friction and ball bearing rail kit

For more information about the tool-less rail kit and cable management arm, see the *Cisco UCS C220 M4 Installation and Service Guide* at this URL:

[http://www.cisco.com/c/en/us/td/docs/unified\\_computing/ucs/c/hw/C220M4/install/C220M4.html](http://www.cisco.com/c/en/us/td/docs/unified_computing/ucs/c/hw/C220M4/install/C220M4.html)



**NOTE:** If you plan to rackmount your UCS HX220c M4 Node, you must order one of the tool-less rail kits.

---

## STEP 10 ORDER A TRUSTED PLATFORM MODULE (OPTIONAL)

Trusted Platform Module (TPM) is a computer chip (microcontroller) that can securely store artifacts used to authenticate the platform. These artifacts can include passwords, certificates, or encryption keys. A TPM can also be used to store platform measurements that help ensure that the platform remains trustworthy. Authentication (ensuring that the platform can prove that it is what it claims to be) and attestation (a process helping to prove that a platform is trustworthy and has not been breached) are necessary steps to ensure safer computing in all environments.

The TPM ordering information is listed in [Table 13](#).

Table 13 Trusted Platform Module

Product ID (PID)	PID Description
UCSX-TPM2-001	Trusted Platform Module 1.2 SPI-based for UCS systems



**NOTE:** The module used in this system conforms to TPM v1.2/1.3, as defined by the Trusted Computing Group (TCG). It is also SPI-based.



## STEP 11 ORDER CISCO FLEXIBLE FLASH SD CARD MODULE

You must order two 64 GB SD cards. The SD cards are mirrored to each other and are used for booting. See [Figure 6 on page 34](#) for the location of the SD cards. There are two locations, SD1 and SD2.

Table 14 64 GB Secure Digital (SD) Card

Product ID (PID)	PID Description
UCS-SD-64G-S	64 GB SD Card

### Caveats

- You must select two 64 GB SD cards

## STEP 12 SELECT OPERATING SYSTEM AND VALUE-ADDED SOFTWARE

Several operating systems and value-added software programs are available. Select as desired from [Table 15](#).

Table 15 OSs and Value-Added Software

PID Description	Product ID (PID)
<b>VMware<sup>1</sup></b>	
HX-VSP-ENT-D	Factory Installed - VMware vSphere6 Enterprise software and License (2 CPU)
HX-VSP-ENT-DL	Factory Installed - VMware vSphere6 Enterprise software Download
HX-VSP-FND-D	Factory Installed - VMware vSphere6 Foundation software and License (2 CPU)
HX-VSP-FND-DL	Factory Installed - VMware vSphere6 Foundation software Download
HX-VSP-EPL-D	Factory Installed - VMware vSphere6 Enterprise Plus software and License (2 CPU)
HX-VSP-EPL-DL	Factory Installed - VMware vSphere6 Enterprise Plus software Download
<b>Software Subscription</b>	
HXDP-001-1YR	Cisco HyperFlex HX Data Platform SW Subscription 1 Year
HXDP-001-3YR	Cisco HyperFlex HX Data Platform SW Subscription 3 Year
HXDP-001-5YR	Cisco HyperFlex HX Data Platform SW Subscription 5 Year

Notes . . .

1. Although VMware 6.0 is installed at the factory, both VMware 5.5 and VMware 6.0 are supported.

## STEP 13 SELECT SERVICE and SUPPORT LEVEL

A variety of service options are available, as described in this section.

### Unified Computing Warranty, No Contract

If you have noncritical implementations and choose to have no service contract, the following coverage is supplied:

- Three-year parts coverage.
- Next business day (NBD) onsite parts replacement eight hours a day, five days a week.
- 90-day software warranty on media.
- Ongoing downloads of BIOS, drivers, and firmware updates.
- UCSM updates for systems with Unified Computing System Manager. These updates include minor enhancements and bug fixes that are designed to maintain the compliance of UCSM with published specifications, release notes, and industry standards.

### Smart Net Total Care for UCS

For support of the entire Unified Computing System, Cisco offers the Cisco Smart Net Total Care for UCS Service. This service provides expert software and hardware support to help sustain performance and high availability of the unified computing environment. Access to Cisco Technical Assistance Center (TAC) is provided around the clock, from anywhere in the world.

For systems that include Unified Computing System Manager, the support service includes downloads of UCSM upgrades. The Cisco Smart Net Total Care for UCS Service includes flexible hardware replacement options, including replacement in as little as two hours. There is also access to Cisco's extensive online technical resources to help maintain optimal efficiency and uptime of the unified computing environment. You can choose a desired service listed in [Table 16](#).

Table 16 Cisco Smart Net Total Care for UCS Service

Product ID (PID)	On Site?	Description
CON-PREM-HX220M4S	Yes	ONSITE 24X7X2 HX220C M4 SFF
CON-OSPT-HX220M4S	Yes	ONSITE Troubleshooting 24x7x4 HX220C M4 SFF
CON-OSP-HX220M4S	Yes	ONSITE 24X7X4 UCS HX220C M4 SFF
CON-OSE-HX220M4S	Yes	ONSITE 8X5X4 HX220C M4 SFF
CON-OS-HX220M4S	Yes	ONSITE 8X5XNBD HX220C M4 SFF
CON-S2P-HX220M4S	No	SMARTNET 24X7X2 HX220C M4 SFF
CON-SNTP-HX220M4S	No	SMARTNET 24X7X4 HX220C M4 SFF
CON-SNTE-HX220M4S	No	SMARTNET 8X5X4 HX220C M4 SFF
CON-SNT-HX220M4S	No	SMARTNET 8X5XNBD HX220C M4 SFF

### Unified Computing Partner Support Service

Cisco Partner Support Service (PSS) is a Cisco Collaborative Services service offering that is designed for partners to deliver their own branded support and managed services to enterprise customers. Cisco PSS provides partners with access to Cisco's support infrastructure and assets to help them:

- Expand their service portfolios to support the most complex network environments
- Lower delivery costs
- Deliver services that increase customer loyalty

Partner Unified Computing Support Options enable eligible Cisco partners to develop and consistently deliver high-value technical support that capitalizes on Cisco intellectual assets. This helps partners to realize higher margins and expand their practice.

PSS is available to all Cisco PSS partners.

The Partner Unified Computing Support Option for the Cisco HX220C Node is:

- Partner Support Service for UCS

Partner Support Service for UCS provides hardware and software support, including triage support for third party software, backed by Cisco technical resources and level three support. See [Table 17](#).

**Table 17 Partner Support Service for UCS**

Product ID (PID)	Service Level GSP	On Site?	Description
CON-PSJ1-HX220M4S	PSJ1	No	UCS SUPP PSS 8X5XNBD HX220C M4 SFF
CON-PSJ2-HX220M4S	PSJ2	No	UCS SUPP PSS 8X5X4 HX220C M4 SFF
CON-PSJ3-HX220M4S	PSJ3	No	UCS SUPP PSS 24X7X4 HX220C M4 SFF
CON-PSJ4-HX220M4S	PSJ4	No	UCS SUPP PSS 24X7X2 HX220C M4 SFF

### Unified Computing Combined Support Service

Combined Services makes it easier to purchase and manage required services under one contract. Smart Net Total Care services for UCS help increase the availability of your vital data center infrastructure and realize the most value from your unified computing investment. The more benefits you realize from the Cisco Unified Computing System (Cisco UCS), the more important the technology becomes to your business. These services allow you to:

- Optimize the uptime, performance, and efficiency of your UCS
- Protect your vital business applications by rapidly identifying and addressing issues
- Strengthen in-house expertise through knowledge transfer and mentoring
- Improve operational efficiency by allowing UCS experts to augment your internal staff resources

- Enhance business agility by diagnosing potential issues before they affect your operations

You can choose a service listed in [Table 18](#).

**Table 18 UCS Computing Combined Support Service**

Product ID (PID)	Service Level GSP	On Site?	Description
CON-NCF2-HX220M4S	NCF2	No	CMB SPT SVC 24X7X2 HX220C M4 SFF
CON-NCF2P-HX220M4S	NCF2P	Yes	CMB SPT SVC 24X7X2OS HX220C M4 SFF
CON-NCF4P-HX220M4S	NCF4P	Yes	CMB SPT SVC 24X7X4OS HX220C M4 SFF
CON-NCF4S-HX220M4S	NCF4S	Yes	CMB SPT SVC 8X5X4OS HX220C M4 SFF
CON-NCFCS-HX220M4S	NCFCS	Yes	CMB SPT SVC 8X5XNBDOS HX220C M4 SFF
CON-NCFE-HX220M4S	NCFE	No	CMB SPT SVC 8X5X4 HX220C M4 SFF
CON-NCFP-HX220M4S	NCFP	No	CMB SPT SVC 24X7X4 HX220C M4 SFF
CON-NCFT-HX220M4S	NCFT	No	CMB SPT SVC 8X5XNBD HX220C M4 SFF

#### Smart Net Total Care for UCS with Drive Retention

With the Smart Net Total Care for UCS with Drive Retention (UCSDR) Service, you can obtain a new disk drive in exchange for a faulty drive without returning the faulty drive. In exchange for a Cisco replacement drive, you provide a signed Certificate of Destruction (CoD) confirming that the drive has been removed from the system listed, is no longer in service, and has been destroyed.

Sophisticated data recovery techniques have made classified, proprietary, and confidential information vulnerable, even on malfunctioning disk drives. The UCDR service enables you to retain your drives and ensures that the sensitive data on those drives is not compromised, which reduces the risk of any potential liabilities. This service also enables you to comply with regulatory, local, and federal requirements.

If your company has a need to control confidential, classified, sensitive, or proprietary data, you might want to consider one of the Drive Retention Services listed in [Table 19 on page 30](#).



**NOTE:** Cisco does not offer a certified drive destruction service as part of this service.

Table 19 Drive Retention Service Options

Service Description	Service Program Name	Service Level GSP	Service Level	Product ID (PID)
Smart Net Total Care for UCS with Drive Retention	UCS DR	UCSD8	24x7x2 Onsite	CON-UCSD8-HX220M4SF
		OSPTD	24x7x4 Onsite Troubleshooting	CON-OPSTD-HX220M4SF
		UCSD7	24x7x4 Onsite	CON-UCSD7-HX220M4S
		UCSD5	8x5xNBD Onsite	CON-UCSD5-HX220M4S

For a complete listing of available services for Cisco Unified Computing System, see this URL:

[http://www.cisco.com/en/US/products/ps10312/serv\\_group\\_home.html](http://www.cisco.com/en/US/products/ps10312/serv_group_home.html)

## OPTIONAL STEP - ORDER RACK(s)

The optional R42610 rack is available from Cisco for the C-Series systems, including the HX220c M4 Node. This rack is a standard 19-inch rack and can be ordered with a variety of options, as listed in [Table 20](#). Racks are shipped separately from the HX220c M4 Node.

Table 20 Racks and Rack Options

Product ID (PID)	PID Description
RACK-UCS <sup>1</sup>	Cisco R42610 expansion rack, no side panels
RACK-UCS2 <sup>1</sup>	Cisco R42610 standard rack, w/side panels
RACK-BLANK-001	Filler panels (qty 12), 1U, plastic, toolless
RACK-CBLMGT-001	Cable mgt D rings (qty 10), metal
RACK-CBLMGT-011	Cable mgt straps (qty 10), Velcro
RACK-FASTEN-001	Mounting screws (qty 100), M6
RACK-FASTEN-002	Cage nuts (qty 50), M6
RACK-JOIN-001	Rack joining kit

Notes . . .

1. Use these same base PIDs to order spare racks (available only as next-day replacements).

For more information about the R42610 rack, see [RACKS, page 42](#).

## OPTIONAL STEP - ORDER PDU

An optional power distribution unit (PDU) is available from Cisco for the HX220c M4 Node. This PDU is available in a zero rack unit (RU) style (see [Table 20](#)).

Table 21 PDU Options

Product ID (PID)	PID Description
RP208-30-2P-U-2	Zero RU PDU

For more information about the PDU, see [PDUs, page 44](#).



# SUPPLEMENTAL MATERIAL

## Hyperconverged Systems

Cisco HyperFlex Systems let you unlock the full potential of hyperconvergence and adapt IT to the needs of your workloads. The systems use an end-to-end software-defined infrastructure approach, combining software-defined computing in the form of Cisco HyperFlex HX-Series nodes; software-defined storage with the powerful Cisco HX Data Platform; and software-defined networking with the Cisco UCS fabric that will integrate smoothly with Cisco Application Centric Infrastructure (Cisco ACI). Together with a single point of connectivity and management, these technologies deliver a preintegrated and adaptable cluster with a unified pool of resources that you can quickly deploy, adapt, scale, and manage to efficiently power your applications and your business.

Figure 5 show a small footprint cluster.

Figure 5 Small Footprint Cluster Using HX220c M4 Nodes

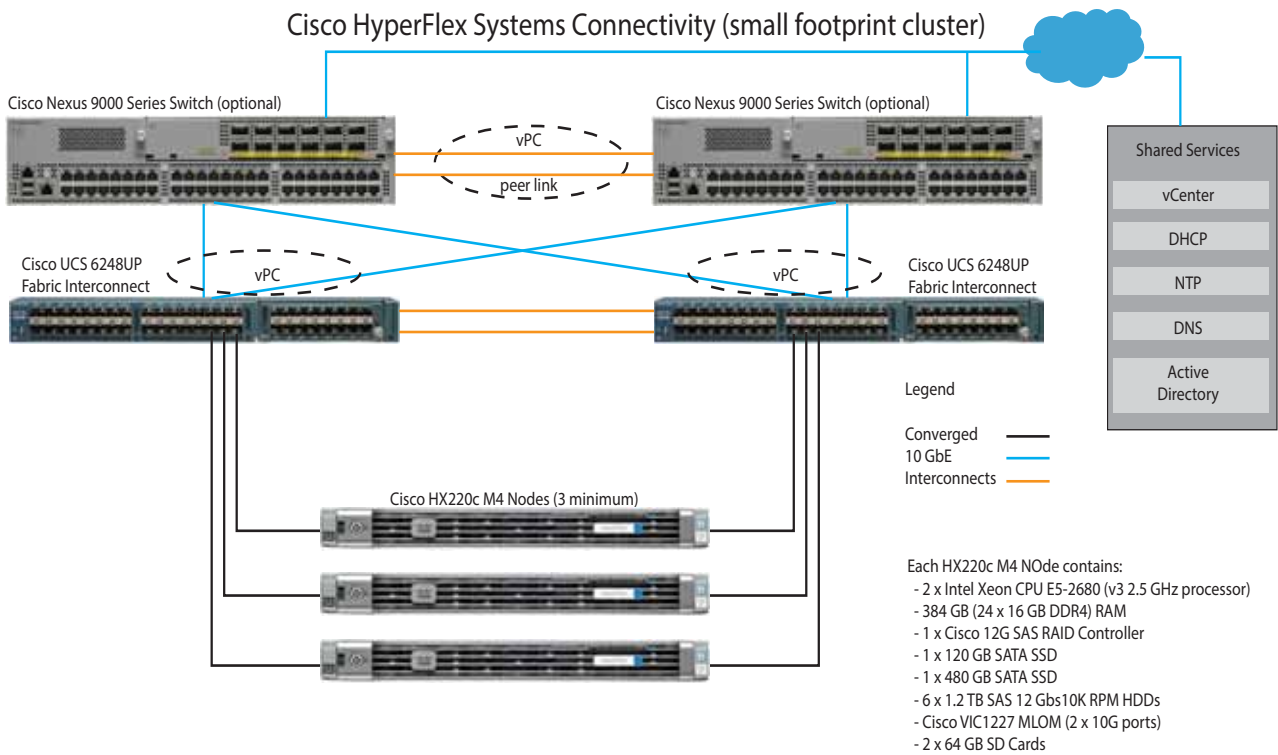

## Chassis

An internal view of the HX220c M4 Node with the top cover removed is shown in *Figure 6*. The location of the two SD cards is marked with callout #7.

Figure 6 HX220c M4 Node With Top Cover Off

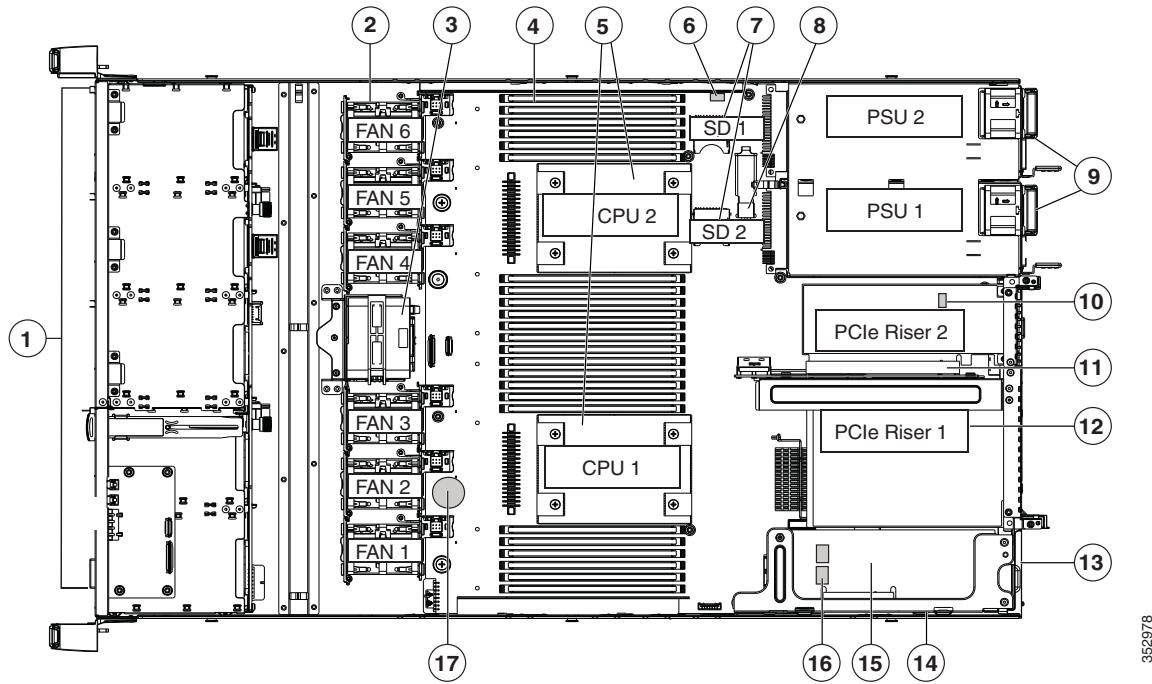

352978

1	Drives (SAS/SATA drives are hot-swappable)	10	Trusted platform module (TPM) socket on motherboard (not visible in this view)
2	Cooling fan modules (six)	11	PCIe riser 2 (half-height PCIe slot 2)
3	SuperCap backup unit mounting location (not used in this system)	12	PCIe riser 1 (full-height PCIe slot 1)
4	DIMM sockets on motherboard (either 16 or 24 DIMMs populated)	13	Modular LOM (mLOM) connector on chassis floor
5	CPUs and heatsinks (two)	14	Cisco 12 Gbps Modular SAS HBA disk controller PCIe riser (dedicated riser with horizontal socket)
6	Embedded SATA RAID header for RAID 5 key (not used)	15	Cisco 12 Gbps Modular SAS HBA controller card
7	Cisco SD card bays on motherboard (two)	16	Embedded SATA RAID mini-SAS connectors on motherboard (not visible in this view and not used)
8	Internal USB 3.0 port on motherboard (not used)	17	RTC battery on motherboard
9	Power supplies (two, hot-swappable when redundant as 1+1)	—	—

## Block Diagram

A simplified block diagram of the HX220c M4 Node is shown in [Figure 7](#).

Figure 7 HX220c M4 Node Block Diagram (simplified)

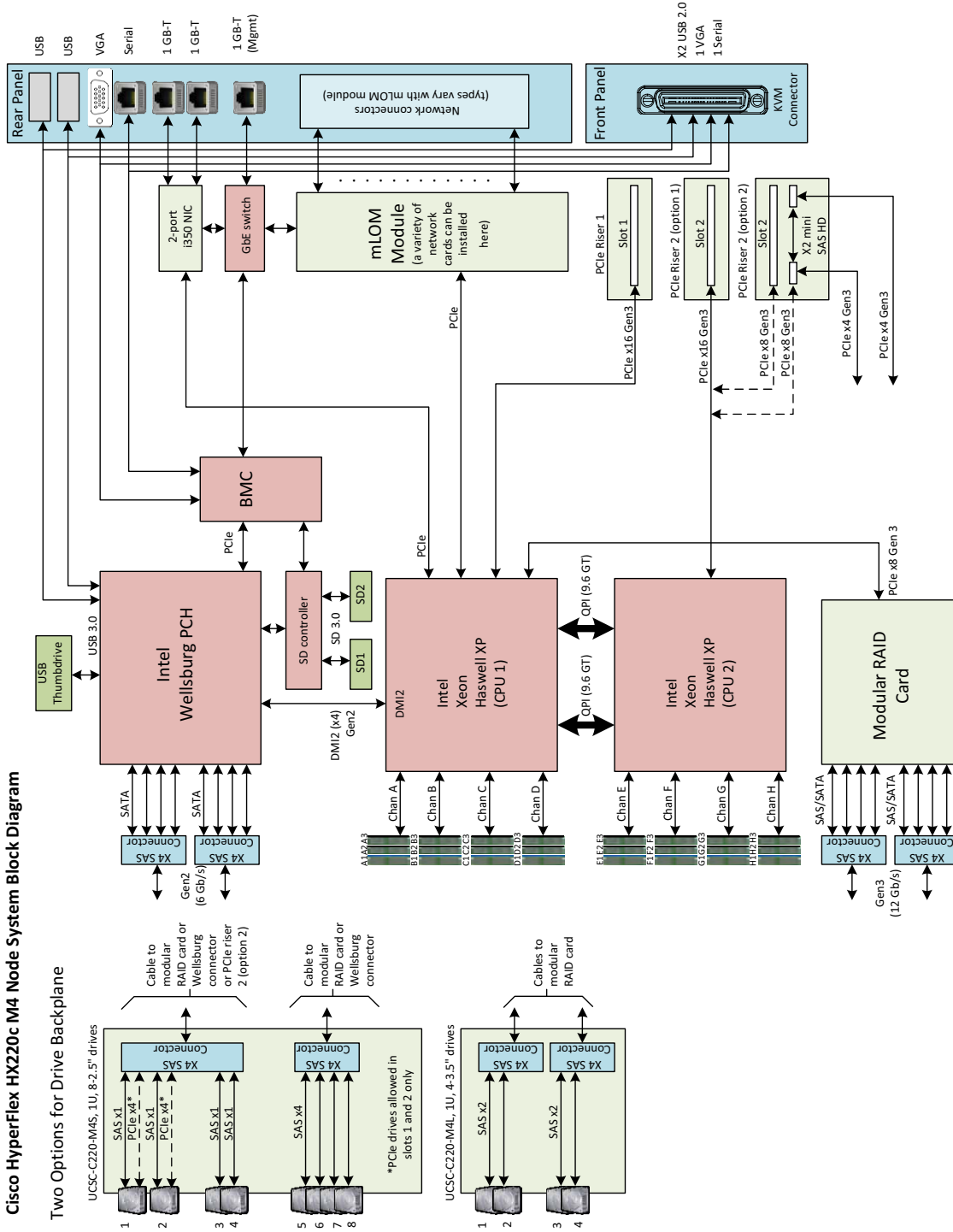

## CPUs and DIMMs

### Physical Layout

Each CPU has four DIMM channels:

- CPU1 has channels A, B, C, and D
- CPU2 has channels E, F, G, and H

Each DIMM channel has three slots: slot 1, slot 2, and slot 3. The blue-colored DIMM slots are for slot 1, the black-colored slots for slot 2, and the white slots for slot 3.

As an example, DIMM slots A1, B1, C1, and D1 belong to slot 1, while A2, B2, C2, and D2 belong to slot 2.

*Figure 8* shows how slots and channels are physically laid out on the motherboard. The DIMM slots on the right half of the motherboard (channels A, B, C, and D) are associated with CPU 1, while the DIMM slots on the left half of the motherboard (channels E, F, G, and H) are associated with CPU 2. The slot 1 (blue) DIMM slots are always located farther away from a CPU than the corresponding slot 2 (black) and slot 3 (white) slots. Slot 1 slots (blue) are populated before slot 2 slots (black) and slot 3 (white) slots.

Figure 8 Physical Layout of CPU DIMM Channels and Slots

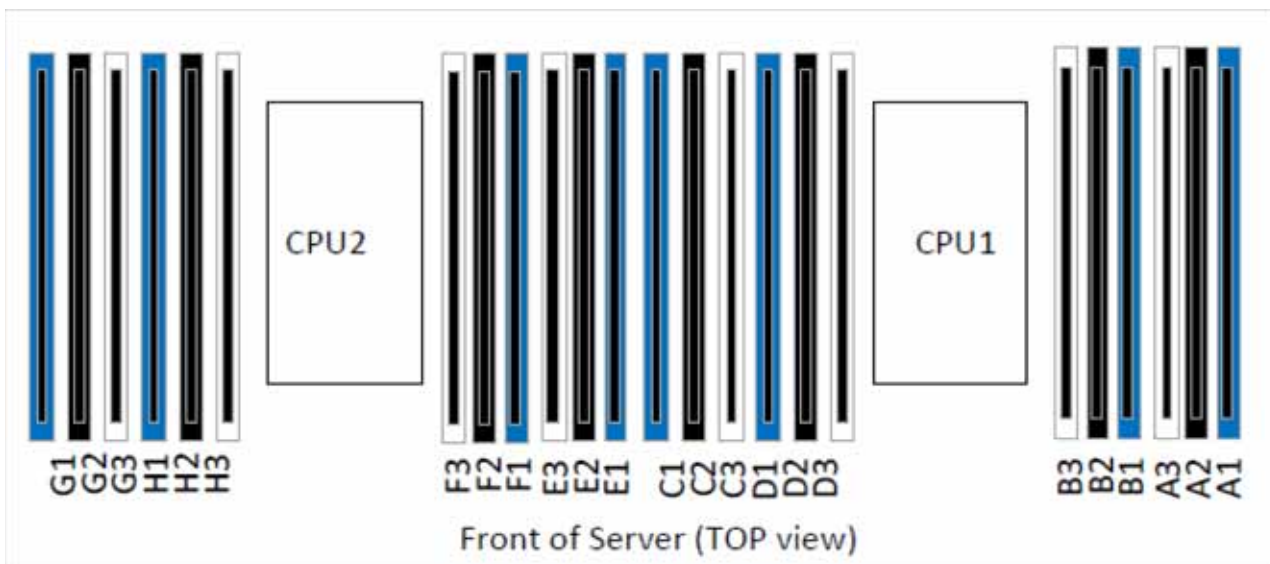

## Memory Population Rules

When considering the memory configuration of your system, you should consider the following items:

- Each channel has three DIMM slots (for example, channel A = slots A1, A2, and A3).
  - A channel can operate with one, two, or three DIMMs installed.
  - If a channel has only one DIMM, populate slot 1 first (the blue slot).
- When both CPUs are installed, populate the DIMM slots of each CPU identically.
  - Fill blue slots in the channels first: A1, E1, B1, F1, C1, G1, D1, H1
  - Fill black slots in the channels second: A2, E2, B2, F2, C2, G2, D2, H2
  - Fill black slots in the channels third: A3, E3, B3, F3, C3, G3, D3, H3
- Any DIMM installed in a DIMM socket for which the CPU is absent is not recognized.
- Observe the DIMM mixing rules shown in [Table 22](#)

Table 22 DIMM Rules for HX220c M4 Node

DIMM Parameter	DIMMs in the Same Channel	DIMM in the Same Slot <sup>1</sup>
<u>DIMM Capacity</u> RDIMM = 16 or 32 GB	DIMMs in the same channel (for example, A1, A2, and A3) can have different capacities.	For best performance, DIMMs in the same slot (for example, A1, B1, C1, D1) should have the same capacity.
<u>DIMM Speed</u> 2133-MHz <sup>2</sup>	DIMMs will run at the lowest speed of the DIMMs/CPUs installed	DIMMs will run at the lowest speed of the DIMMs/CPUs installed
<u>DIMM Type</u> RDIMMs		
<b>DIMMs per Channel (DPC)</b>	<b>1 DPC, 2 DPC, or 3 DPC</b>	
	See <a href="#">Table 5 on page 14</a> for valid RDIMM 1 DPC, 2 DPC, and 3 DPC memory configurations	

Notes . . .

1. Although you can have different DIMM capacities in the same slot, this will result in less than optimal performance. For optimal performance, all DIMMs in the same slot should be identical.
2. Only 2133-MHz DIMMs are currently available for the HX220c M4 node.

## DIMM Population Order

Populate the DIMMs for a CPU according to [Table 23](#).

Table 23 DIMM Population Order per CPU

DIMMs per CPU	Populate CPU 1 Slots	Populate CPU 2 Slots
8	A1, B1, C1, D1, A2, B2, C2, D2	E1, F1, G1, H1, E2, F2, G2, H2
12	A1, B1, C1, D1, A2, B2, C2, D2 A3, B3, C3, D3	E1, F1, G1, H1, E2, F2, G2, H2 E3, F3, G3, H3

## Serial Port Details

The pinout details of the rear RJ-45 serial port connector are shown in [Figure 9](#).

Figure 9 Serial Port (Female RJ-45 Connector) Pinout

### Serial Port (RJ-45 Female Connector)

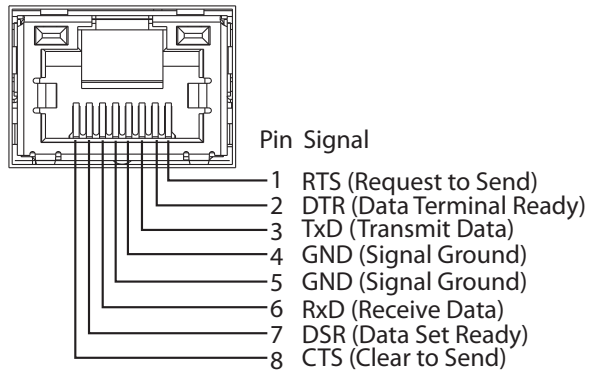

## Upgrade and Servicing-Related Parts

This section lists the upgrade and servicing-related parts you may need during the life of your system. Some of these parts are configured with every system, and some may be ordered when needed or may be ordered and kept on hand as spares for future use. See [Table 24](#).

Table 24 Upgrade and Servicing-related Parts for UCS HX220c M4 Node

Spare Product ID (PID)	Description
UCSC-HS-C220M4=	Heat sink
UCS-CPU-GREASE3=	Thermal grease syringe - needed for heatsink seal
UCS-CPU-LPCVR=	CPU load plate dust cover (for unpopulated CPU sockets)
UCSX-HSCK=	UCS Processor Heat Sink Cleaning Kit For Replacement of CPU
UCSC-PCI-2A-220M4=	PCIe Riser 1&2 Assy
UCSC-PCI-2C-220M4=	PCIe Riser 3 (HBA)
UCSC-PCIF-01H=	PCIe Low Profile blanking panel
UCSC-PCIF-01F=	PCIe Full Height blanking panel
N20-BBLKD	HDD blanking panel <sup>1</sup>
UCSC-MLOM-BLK=	MLOM blanking panel
UCSC-RAILF-M4=	Tool-Less Friction Rail Kit
UCSC-CMAF-M4=	Reversible CMA for friction & ball bearing rail kits
UCSC-RAILB-M4=	Tool-Less Ball Bearing Rail Kit
UCSC-FAN-C220M4=	Fan Module (one)
UCSC-BAFF-C220M4=	Air Baffle, Plastic Kit
N20-BKVM=	KVM cable for console port
UCSC-PSU-BLKP1U=	Power supply blanking panel
UCS-220CBLSR8=	Set of 2 SATA/SW RAID cables for 8HDD bckpln chassis <sup>2</sup>
UCS-220CBLMR8=	Set of 2 RAID cntrlr cables for 8HDD bckpln chassis <sup>2</sup>
UCSC-EARS-C220M4=	Rack ears kit (two ears)

### Notes . . .

1. A drive blanking panel must be installed if you remove a disk drive from the system. These panels are required to maintain system temperatures at safe operating levels, and to keep dust away from system components.
2. Required if ordering the RAID controller as a spare or to replace damaged cables



## Motherboard Lithium Battery

You can order a replacement motherboard battery. Installation instructions are found at this link:

[http://www.cisco.com/c/en/us/td/docs/unified\\_computing/ucs/c/hw/C220M4/install/C220M4.html](http://www.cisco.com/c/en/us/td/docs/unified_computing/ucs/c/hw/C220M4/install/C220M4.html)

See the section titled “Replacing the Motherboard RTC Battery.”

## Thermal Grease (with syringe applicator) for CPU to Heatsink Seal

Thermal grease must be applied to the top of the CPU where it comes in contact with the heat sink (a grease syringe also ships with each CPU spare option kit). Instructions for applying thermal grease are found at:

[http://www.cisco.com/c/en/us/td/docs/unified\\_computing/ucs/c/hw/C220M4/install/C220M4.html](http://www.cisco.com/c/en/us/td/docs/unified_computing/ucs/c/hw/C220M4/install/C220M4.html)

See the section titled “Replacing CPUs and Heatsinks.”



**CAUTION:** Use only the thermal grease specified for this system (UCS-CPU-GREASE3=). This thermal grease comes in a white-tipped syringe and is to be used only in the HX220c M4 and HX240c M4 Nodes. Other systems use thermal grease in a blue-tipped syringe (UCS-CPU-GREASE=).

Thermal grease for other systems may have different thermal conductivity properties and may cause overheating if used in the HX220c M4 or HX240c M4 Nodes.

**DO NOT** use thermal grease available for purchase at any commercial electronics store. If these instructions are not followed, the CPU may overheat and be destroyed.

---



**NOTE:** When you purchase a spare CPU, the thermal grease with syringe applicator is included.

---

## Air Baffle Replacement Kit

Air baffles are designed to direct airflow through the chassis to maintain the temperature at a safe operating level. These baffles must always remain installed during operation. The Air Baffle Replacement Kit includes the air baffles needed for one HX220c M4 Node.

## RACKS

The Cisco R42610 rack (see [Figure 10](#)) is certified for Cisco UCS installation at customer sites and is suitable for the following equipment:

- Cisco UCS B-Series servers and fabric interconnects
- Cisco UCS C-Series and select Nexus switches

The rack is compatible with hardware designed for EIA-standard 19-inch racks. Rack specifications are listed in [Table 25](#).

Table 25 Cisco R42610 Rack Specifications

Parameter	Standard Rack	Expansion Rack
Dimensions (H x W x D)	78.74 x 24 x 43.38 in. (2000 x 610 x 1102 mm)	78.74 x 23.58 x 43.38 in. (2000 x 599 x 1102 mm)
Dimensions (H x W x D) with packaging	89 x 33 x 47 in. (2261 x 838 x 1194 mm)	89 x 33 x 47 in. (2261 x 838 x 1194 mm)
Distance from front mounting rail to rear mounting rail	29.2 in (741 mm)	29.2 in (741 mm)
Weight	299.83 lb (136 kg)	231.49 lb (105 kg)
Weight with packaging	354 lb (161 kg)	284 lb (129 kg)
Side panels included	Yes	No
Equipment mounting capacity	42RU	42RU
Static load capacity	2100 lb (954 kg)	2100 lb (954 kg)
Dynamic load capacity	Not applicable	Not applicable



**NOTE:** The AC input connector is an IEC 320 C-14 15 A/250 VAC power inlet.

Figure 10 Cisco R42610 Rack



Front view - door



Front view - door open



Front view - door removed

## PDU

Cisco RP Series Power Distribution Units (PDUs) offer power distribution with branch circuit protection.

Cisco RP Series PDU models distribute power to up to 24 outlets. The architecture organizes power distribution, simplifies cable management, and enables you to move, add, and change rack equipment without an electrician.

With a Cisco RP Series PDU in the rack, you can replace up to two dozen input power cords with just one. The fixed input cord connects to the power source from overhead or under-floor distribution. Your IT equipment is then powered by PDU outlets in the rack using short, easy-to-manage power cords.

The C-series severs accept the zero-rack-unit (ORU) PDU. See [Figure 11](#).

Figure 11 Zero Rack Unit PDU (PID = RP208-30-2P-U-2)

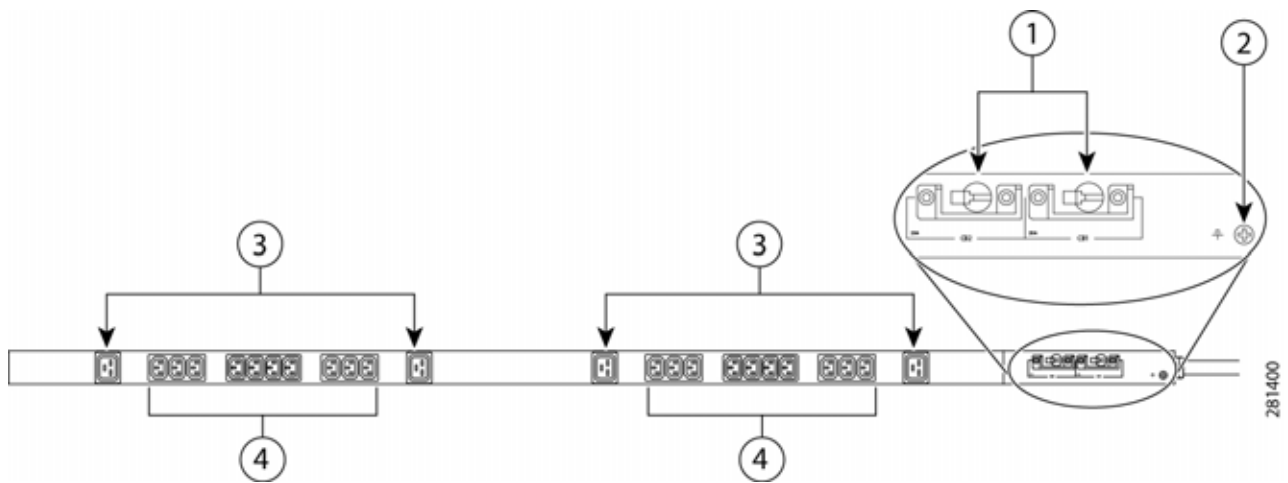

1	Breakers	3	C19 plugs
2	Ground connection	4	C13 plugs

Cisco RP Series PDU models provide two 20-ampere (A) circuit breakers for groups of receptacles. The effects of a tripped circuit are limited to a receptacle group. Simply press a button to reset that circuit.

## KVM CABLE

The KVM cable provides a connection into the system, providing a DB9 serial connector, a VGA connector for a monitor, and dual USB ports for a keyboard and mouse. With this cable, you can create a direct connection to the operating system and the BIOS running on the system.

The KVM cable ordering information is listed in [Table 26](#).

Table 26 KVM Cable

Product ID (PID)	PID Description
N20-BKVM=	KVM cable for console port

Figure 12 KVM Cable

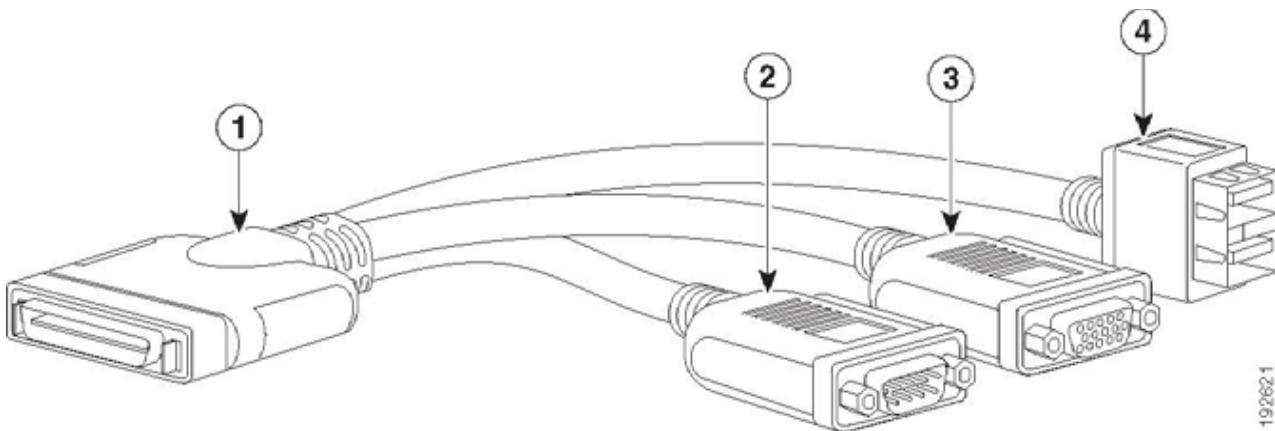

1	Connector (to front panel)	3	VGA connector (for a monitor)
2	DB-9 serial connector	4	Two-port USB connector (for a mouse and keyboard)

## TECHNICAL SPECIFICATIONS

### Dimensions and Weight

Table 27 HX220c M4 Node Dimensions and Weight

Parameter	Value
Height	1.7 in. (4.32 cm)
Width	16.89 in. (43.0 cm) including handles: 18.98 in. (48.2 cm)
Depth	29.8 in. (75.6 cm) including handles: 30.98 in. (78.7 cm)
Front Clearance	3 in. (76 mm)
Side Clearance	1 in. (25 mm)
Rear Clearance	6 in. (152 mm)
Weight <sup>1</sup>	
Maximum (8 drives, two 2 CPUs, 24 DIMMs, two power supplies)	37.9 lbs (17.2 kg)

Notes . . .

1. Weight includes inner rail, which is attached to the system. Weight does not include outer rail, which is attached to the rack.

## Power Specifications

The general power specifications for the HX220c M4 Node 770 W (AC) power supply are listed in [Table 28](#).

Table 28 HX220c M4 Node 770 W (AC) Power Supply Specifications

Description	Specification
AC input voltage	100–240 VAC (nominal input voltage range) 90–264 VAC (min/max input voltage range)
AC input frequency	47 to 63 Hz (single phase)
Maximum AC input current	9.5 Amps maximum at 100 VAC 4.5 Amps maximum at 208 VAC
Maximum Input VA	915 at 230 VAC
Maximum output power for each power supply	770 W on 12 VDC main 36 W on 12 VDC standby
Maximum AC inrush current	15 A (subcycle duration)
Power supply output voltage	12 VDC $\pm$ 5%
Power supply efficiency	Climate Savers Platinum Efficiency (80Plus Platinum Certified)
Form factor	RSP2
Input connector	IEC320 C14

For configuration-specific power specifications, use the Cisco UCS Power Calculator at this URL:

<http://ucspowercalc.cisco.com>

## Environmental Specifications

The power specifications for the HX220c M4 Node are listed in [Table 29](#).

Table 29 HX220c M4 Node Environmental Specifications

Parameter	Minimum
Temperature operating	41 to 95° F (5 to 35° C) derate the maximum temperature by 1° C per every 1000 ft. (305 m) of altitude above sea level
Temperature nonoperating	-40 to 149° F (-40 to 65° C)
Humidity (RH) operating	10 to 90%, non-condensing at 82° F (28° C)
Humidity (RH) nonoperating	5 to 93% at 82° F (28° C)
Altitude operating	0 to 3,000 m (0 to 10,000 ft.)
Altitude nonoperating	0 to 12,192 m (0 to 40,000 ft.)
Sound Power level, Measure A-weighted per ISO7779 LWAd (Bels) Operation at 73° F (23° C)	5.4
Sound Pressure level, Measure A-weighted per ISO7779 LpAm (dBA) Operation at 73° F (23° C)	37



## Compliance Requirements

The regulatory compliance requirements for C-Series systems are listed in [Table 30](#).

**Table 30 UCS C-Series Regulatory Compliance Requirements**

Parameter	Description
Regulatory Compliance	Products should comply with CE Markings per directives 2004/108/EC and 2006/95/EC
Safety	UL 60950-1 Second Edition CAN/CSA-C22.2 No. 60950-1 Second Edition EN 60950-1 Second Edition IEC 60950-1 Second Edition AS/NZS 60950-1 GB4943 2001
EMC - Emissions	47CFR Part 15 (CFR 47) Class A AS/NZS CISPR22 Class A CISPR22 Class A EN55022 Class A ICES003 Class A VCCI Class A EN61000-3-2 EN61000-3-3 KN22 Class A CNS13438 Class A
EMC - Immunity	EN55024 CISPR24 EN300386 KN24



---

**Americas Headquarters**  
Cisco Systems, Inc.  
San Jose, CA

**Asia Pacific Headquarters**  
Cisco Systems (USA) Pte. Ltd.  
Singapore

**Europe Headquarters**  
Cisco Systems International BV Amsterdam,  
The Netherlands

---

Cisco has more than 200 offices worldwide. Addresses, phone numbers, and fax numbers are listed on the Cisco Website at [www.cisco.com/go/offices](http://www.cisco.com/go/offices).

---

Cisco and the Cisco Logo are trademarks of Cisco Systems, Inc. and/or its affiliates in the U.S. and other countries. A listing of Cisco's trademarks can be found at [www.cisco.com/go/trademarks](http://www.cisco.com/go/trademarks). Third party trademarks mentioned are the property of their respective owners. The use of the word partner does not imply a partnership relationship between Cisco and any other company. (1005R)