



## **System Installation and Upgrade Manual for Contact Center**

Cisco Unified Communications System Release 6.1(1)

### **Americas Headquarters**

Cisco Systems, Inc.  
170 West Tasman Drive  
San Jose, CA 95134-1706  
USA  
<http://www.cisco.com>  
Tel: 408 526-4000  
800 553-NETS (6387)  
Fax: 408 527-0883

Text Part Number: OL-15524-01

NOTICE. ALL STATEMENTS, INFORMATION, AND RECOMMENDATIONS IN THIS MANUAL ARE BELIEVED TO BE ACCURATE BUT ARE PRESENTED WITHOUT WARRANTY OF ANY KIND, EXPRESS OR IMPLIED. USERS MUST TAKE FULL RESPONSIBILITY FOR THEIR APPLICATION OF ANY PRODUCTS.

THE SOFTWARE LICENSE AND LIMITED WARRANTY FOR THE ACCOMPANYING PRODUCT ARE SET FORTH IN THE INFORMATION PACKET THAT SHIPPED WITH THE PRODUCT AND ARE INCORPORATED HEREIN BY THIS REFERENCE. IF YOU ARE UNABLE TO LOCATE THE SOFTWARE LICENSE OR LIMITED WARRANTY, CONTACT YOUR CISCO REPRESENTATIVE FOR A COPY.

The Cisco implementation of TCP header compression is an adaptation of a program developed by the University of California, Berkeley (UCB) as part of UCB's public domain version of the UNIX operating system. All rights reserved. Copyright © 1981, Regents of the University of California.

NOTWITHSTANDING ANY OTHER WARRANTY HEREIN, ALL DOCUMENT FILES AND SOFTWARE OF THESE SUPPLIERS ARE PROVIDED "AS IS" WITH ALL FAULTS. CISCO AND THE ABOVE-NAMED SUPPLIERS DISCLAIM ALL WARRANTIES, EXPRESSED OR IMPLIED, INCLUDING, WITHOUT LIMITATION, THOSE OF MERCHANTABILITY, FITNESS FOR A PARTICULAR PURPOSE AND NONINFRINGEMENT OR ARISING FROM A COURSE OF DEALING, USAGE, OR TRADE PRACTICE.

IN NO EVENT SHALL CISCO OR ITS SUPPLIERS BE LIABLE FOR ANY INDIRECT, SPECIAL, CONSEQUENTIAL, OR INCIDENTAL DAMAGES, INCLUDING, WITHOUT LIMITATION, LOST PROFITS OR LOSS OR DAMAGE TO DATA ARISING OUT OF THE USE OR INABILITY TO USE THIS MANUAL, EVEN IF CISCO OR ITS SUPPLIERS HAVE BEEN ADVISED OF THE POSSIBILITY OF SUCH DAMAGES.

CCVP, the Cisco logo, and Welcome to the Human Network are trademarks of Cisco Systems, Inc.; Changing the Way We Work, Live, Play, and Learn is a service mark of Cisco Systems, Inc.; and Access Registrar, Aironet, Catalyst, CCDA, CCDP, CCIE, CCIP, CCNA, CCNP, CCSP, Cisco, the Cisco Certified Internetwork Expert logo, Cisco IOS, Cisco Press, Cisco Systems, Cisco Systems Capital, the Cisco Systems logo, Cisco Unity, Enterprise/Solver, EtherChannel, EtherFast, EtherSwitch, Fast Step, Follow Me Browsing, FormShare, GigaDrive, HomeLink, Internet Quotient, IOS, iPhone, IP/TV, iQ Expertise, the iQ logo, iQ Net Readiness Scorecard, iQuick Study, LightStream, Linksys, MeetingPlace, MGX, Networkers, Networking Academy, Network Registrar, PIX, ProConnect, ScriptShare, SMARTnet, StackWise, The Fastest Way to Increase Your Internet Quotient, and TransPath are registered trademarks of Cisco Systems, Inc. and/or its affiliates in the United States and certain other countries.

All other trademarks mentioned in this document or Website are the property of their respective owners. The use of the word partner does not imply a partnership relationship between Cisco and any other company. (0711R)

Any Internet Protocol (IP) addresses used in this document are not intended to be actual addresses. Any examples, command display output, and figures included in the document are shown for illustrative purposes only. Any use of actual IP addresses in illustrative content is unintentional and coincidental.

*System Installation and Upgrade Manual for Contact Center, Cisco Unified Communications System Release 6.1(1)*

*Copyright © 2008 Cisco Systems, Inc. All rights reserved.*



# CONTENTS

OL-15524-01 1

## **Preface 7**

- Purpose 7
- Audience 7
- Organization 7
- Related Documentation 8

---

## **System Installation for Contact Center**

---

### **CHAPTER 1**

## **Planning Your System Installation 1**

- Cisco Unified Communications System Overview 1
- Scope of this Installation Documentation 2
- System Installation Overview 2
  - Installation Types 3
  - Release Sets 3
    - Legacy Deployment and Installed Base Release Sets 3
    - Greenfield Deployment Release Set 3
  - System Installation Roadmap 4
  - Components Installation Overview 4
- System Installation Strategies 8
  - Single-Stage Installation Using New Hardware (for Greenfield Deployments) 8
  - Single-Stage Installation Using New Hardware (for Legacy Deployments) 8
  - Multistage Installation using New Hardware (for Legacy Deployments) 9
  - Multisite Phased Installation 9
- Interoperability and Compatibility Portals 9

---

### **CHAPTER 2**

## **Preparing for Your System Installation 1**

- Before You Begin 1
- System Installation Approach 3
- Release Set Versions 3
  - Software Version Matrix 4

System Installation Dependencies 6

**CHAPTER 3**

**Performing Your System Installation 1**

- Deployment Models 1
  - Single-Site Model 2
  - Multisite Centralized Model 3
  - Multisite Distributed Model 5
  - Clustering over the WAN Model 5
- Installing Components 6
  - Single-Stage Installation 6
  - Multistage System Installation 7
- Postinstallation Tasks 9
- Related Documentation 10
  - Compatibility Guides 10
  - Component Release Notes and Installation and Upgrade Documents 10

**System Upgrade for Contact Center**

**CHAPTER 4**

**Planning Your System Upgrade 1**

- Cisco Unified Communications System Overview 1
  - Scope of this Upgrade Documentation 2
- Release Sets 2
- Upgrade Roadmap 3
- Upgrade Overview 4
  - Existing Components in Base Release Set 4
  - New Components and Features in Target Release Set 5
  - Components Not in Target Release Set 5
- System Upgrade Paths 6
  - Upgrading from IPC Systems Test Release Sets 6
  - Upgrading from Cisco Unified Communications System Release Sets 7
  - Upgrade Paths to Cisco Unified Communications System Release 6.1(1) 7
- System Upgrade Strategies 8
  - Single-Stage Upgrade Using Existing Hardware 9
  - Single-Stage Upgrade Using New Hardware 10
  - Multistage System Upgrade Using Existing Hardware (Hybrid System) 11
  - Multisite Migration (Hybrid Network) 12

**CHAPTER 5****Preparing for Your System Upgrade 1**

- System Upgrade Approach 1
- System Upgrade Dependencies 2
  - Cisco Unified Communications Manager Upgrade and Compatibility Considerations 2
    - Upgrading from Cisco Unified Communications Manager 6.0(1) to Release 6.1(1a) 2
  - Cisco Unified IP Phone 3
  - Backward Compatibility Issues 4
    - Backward Compatibility Scenarios 4
- Upgrade Release Versions 6
  - Release 6.0(1) and Release 6.1(1) Software Release Sets 6

**CHAPTER 6****Performing Your System Upgrade 1**

- Deployment Models 1
  - Single-Site Model 2
  - Multisite Centralized Model 3
  - Multisite Distributed Model 3
  - Clustering over the WAN (CoW) Model 4
- Upgrading Components 5
  - Single-Stage Upgrade 6
  - Multistage System Upgrade 6
  - Upgrading Contact Center Test Beds 8
- Related Documentation 8
  - Compatibility Guides 8
  - Component Release Notes and Installation and Upgrade Documents 9

**INDEX**





## Preface

---

### Purpose

This document provides installation and upgrade information about contact center components and configurations that have been tested and verified as a part of Cisco Unified Communications system testing. It consists of two parts:

- Part 1: System Installation for Contact Center—Provides the system-level information required to install contact center components in Cisco Unified Communications System Release 6.1(1).
- Part 2: System Upgrade for Contact Center—Provides the system-level information required to upgrade contact center components from Cisco Unified Communications Release 6.0(1) to Cisco Unified Communications Release 6.1(1).



#### Note

---

Many of the contact center component names have changed as part of Cisco Unified Communications System releases. Only the latest product names are used in this document, even when referencing products from previous releases.

---

### Audience

This document is intended for system administrators who are familiar with the various hardware and software components included in the Cisco Unified Communications System family of contact center products. Readers should have the technical and product knowledge to install, configure, manage, and troubleshoot the system described.

### Organization

The document is divided into the following topics:

Topic	Description
Part 1: System Installation for Contact Center	
<a href="#">Chapter 1, “Planning Your System Installation”</a>	Provides an overview of the system installation, a list of components in a typical contact center environment, and different installation strategies.

Topic	Description
<a href="#">Chapter 2, “Preparing for Your System Installation”</a>	Discusses the general approach for the installation of contact center components, installation release set versions, and software dependencies and considerations.
<a href="#">Chapter 3, “Performing Your System Installation”</a>	Provides information about the installation order and process for all contact center components configured in specific deployment models.
Part 2: System Upgrade for Contact Center	
<a href="#">Chapter 4, “Planning Your System Upgrade”</a>	Provides an overview of the system upgrade requirements, the targeted release sets involved in the upgrade process, and upgrade paths and strategies.
<a href="#">Chapter 5, “Preparing for Your System Upgrade”</a>	Discusses the general upgrade approach for the different contact center components, upgrade release versions, and software compatibility considerations.
<a href="#">Chapter 6, “Performing Your System Upgrade”</a>	Provides information about the upgrade order and process for all contact center components configured in specific deployment models.

## Related Documentation

The Cisco Unified Communications System Technical Information Site at <http://www.cisco.com/go/unified-techinfo> is your one-stop location for all system-level documentation, resources, and training. This site provides a suite of interactive documentation that covers details of the system architecture and components, installation and upgrade information, troubleshooting, topology diagrams, and related information.

The sites specific to IP telephony or contact center system applications for Cisco Unified Communications System Release 6.1(1) are:

- Cisco Unified Communications System for Contact Center Release 6.1(1) at: <http://www.cisco.com/cisco/web/docs/iam/unified/ipcc611/index.html>
- Cisco Unified Communications System for IP Telephony Release 6.1(1) at: <http://www.cisco.com/cisco/web/docs/iam/unified/ipt611/index.html>

## Obtaining Documentation and Submitting a Service Request

For information on obtaining documentation, submitting a service request, and gathering additional information, see the monthly *What’s New in Cisco Product Documentation*, which also lists all new and revised Cisco technical documentation, at:

<http://www.cisco.com/en/US/docs/general/whatsnew/whatsnew.html>

Subscribe to the *What’s New in Cisco Product Documentation* as a Really Simple Syndication (RSS) feed and set content to be delivered directly to your desktop using a reader application. The RSS feeds are a free service and Cisco currently supports RSS version 2.0.





## **PART 1**

# **System Installation for Contact Center**





# CHAPTER 1

## Planning Your System Installation

---

This topic provides an overview of the primary components typically deployed in a contact center environment and the installation processes for contact center components. It also describes the types of installations and various installation strategies.

This topic contains the following sections:

- [Cisco Unified Communications System Overview](#)
- [Scope of this Installation Documentation](#)
- [System Installation Overview](#)
- [System Installation Strategies](#)
- [Interoperability and Compatibility Portals](#)



### Note

---

Many of the contact center component names have changed as part of Cisco Unified Communications System releases. Only the latest product names are used in this document, even when referencing products from previous releases.

---

## Cisco Unified Communications System Overview

The Cisco Unified Communications System is a full-featured business communications system built into an intelligent IP network. It enables voice, data, and video communications for businesses of all sizes. The Cisco Unified Communications System is defined around commonly deployed enterprise topology models in North America and European & Emerging Markets (EUEM).

Cisco Systems provides an integrated system to meet customer needs. The system contains a number of communications products that are designed, developed, tested, documented, sold, and supported as one entity. This system is built upon individual IP telephony and contact center products including, but not limited to, the Cisco Unified Communications Manager (formerly known as Cisco Unified CallManager), Cisco Unified Intelligent Contact Management Enterprise (Unified ICM), Cisco Unified Customer Voice Portal (Unified CVP), Cisco Unified Contact Center Enterprise (Unified CCE), Cisco Customer Response Solutions (CRS), and voice-capable gateways and routers.

Cisco Unified Contact Center solutions allow you to move beyond today's contact center to a customer interaction network by creating a better customer experience, making customer-service agents more efficient and productive, improving contact center reporting, and extending the workforce with expert, mobile, and remote agents.

Cisco Unified Communications System testing is a process for specifying (designing) and validating the interoperability of enterprise voice products to ensure that they work together as an integrated system.

# Scope of this Installation Documentation

The installation procedures that are described in this document are intended to provide a high-level guide to installing the Cisco Unified Communications System. This document provides installation information from a system perspective and only for the products that are part of Cisco Unified Communications System Release 6.1(1).

The Cisco Unified Communications contact center system should have the following basic characteristics and requirements:

- A deployment that is based on Cisco recommendations and guidelines for network design, architecture, and deployment models
- A new *greenfield* system deployment or integration with a legacy system deployment
- An installation of these systems, not an upgrade from previous software versions

**Note**

---

If you have a legacy system with PBXs and other such products that need to interoperate with the Cisco Unified Communications system, see [Interoperability and Compatibility Portals](#) for interoperability and integration information.

---

Because of the variety of the installations and the complexity of the procedures that are required to completely set up a contact center system, this document does not provide installation procedures for:

- Individual standalone components and features of these components
- Third-party coresident applications such as antivirus, security, and remote access
- Additional third-party off-board applications such as operator console, and billing and accounting
- Server replacement (hardware installation) for components

Refer to product-specific installation documents to perform the installation and configuration of the contact center products.

- Product-specific installation documentation for all Cisco voice products is available at: [http://www.cisco.com/en/US/products/sw/voicesw/tsd\\_products\\_support\\_category\\_home.html](http://www.cisco.com/en/US/products/sw/voicesw/tsd_products_support_category_home.html)
- Links to component-specific installation documents for all contact center components in the Cisco Unified Communications System Release 6.1(1) are available at: [http://www.cisco.com/cisco/web/docs/iam/unified/ipcc611/Component\\_Installation\\_and\\_Configuration\\_Guides.html](http://www.cisco.com/cisco/web/docs/iam/unified/ipcc611/Component_Installation_and_Configuration_Guides.html)

Also see Related Documentation in [Chapter 3, “Performing Your System Installation”](#).

## System Installation Overview

This section includes the following sections:

- [Installation Types](#)
- [Release Sets](#)
- [System Installation Roadmap](#)
- [Components Installation Overview](#)

## Installation Types

The following types of deployments should be considered when installing and creating a contact center environment:

- Greenfield deployment—A completely new installation of the Cisco Unified Communications system, using no existing equipment.
- Legacy deployment—A new installation of the Cisco Unified Communications system combined with existing legacy equipment, such as TDM PBXs and third-party adjuncts, which may require long-term co-existence and integration or eventual migration to the new installation.
- Installed base (“brownfield” deployment)—An existing Cisco Unified Communications system, which requires an upgrade/migration from a previous system release to the current system release. For more information about upgrading an existing installation, see the system upgrade topics later in this document.

**Note**

---

When performing upgrades, be aware of backward compatibility issues such as coexistence and interoperability with sites on previous system release versions.

---

## Release Sets

A *release set* is defined as the combination of products, components, and software versions that were tested to work together as an integrated Cisco Unified Communications system. A particular system release is also referred to as a release set.

### Legacy Deployment and Installed Base Release Sets

If you are dealing with a legacy or “brownfield” deployment, you need to be aware of interoperability issues between legacy or existing component versions and the Cisco Unified Communications System Release 6.1(1) component versions.

You can browse a previous system release set by product release version in a summary matrix. Use the following links if you are unfamiliar with the version content of release sets deployed in contact center environments:

- Cisco Unified Communications System Release Summary Matrix for Contact Center at:  
<http://www.cisco.com/univercd/cc/td/doc/systems/unified/ccmtrix.htm>
- IP Communications System Test Release at:  
[http://www.cisco.com/univercd/cc/td/doc/product/voice/ip\\_tele/gblink/ipcmtrix.htm](http://www.cisco.com/univercd/cc/td/doc/product/voice/ip_tele/gblink/ipcmtrix.htm)

You can also see [Interoperability and Compatibility Portals](#) for information about support for legacy products and third-party product interoperability with Cisco contact center products.

### Greenfield Deployment Release Set

If you are dealing with a greenfield deployment, be aware that certain features, applications, and components are part of the Cisco Unified Communications System Release 6.1(1) family of products and have been tested and verified for interoperability and compatibility.

Based on your specific network design, you may choose to install all or some of these features, applications, and components. For a list of components that apply to a contact center environment, see [Components Installation Overview](#).

For information about the Cisco Unified Communications System Release 6.1(1) contact center components and their software and firmware versions, see Release Set Versions in [Chapter 2, “Preparing for Your System Installation”](#).

## System Installation Roadmap

[Table 1-1](#) provides an overview of the tasks that are performed in the installation of the Cisco Unified Communications contact center system.

**Table 1-1 Overview of Installation Tasks**

	Task	Remarks
<b>Step 1</b>	Perform preinstallation tasks.	See Before You Begin in <a href="#">Chapter 2, “Preparing for Your System Installation,”</a> and refer to the tasks that are described in the individual product installation documents.
<b>Step 2</b>	Install and cable the hardware.	—
<b>Step 3</b>	Install and configure the software for the components to enable functionality between the installed components.	See <a href="#">Chapter 3, “Performing Your System Installation,”</a> and refer to the configuration tasks that are described in the individual product installation and configuration documents.
<b>Step 4</b>	Initialize installed components and ensure that components are functional.	<ul style="list-style-type: none"> <li>• Applications at the system level (such as cold start, elapse time)</li> <li>• Each application at the node level</li> </ul>
<b>Step 5</b>	Perform verification and validation testing in between installing components to ensure that the installed components interoperate.	—
<b>Step 6</b>	Integrate between Cisco and third-party or legacy products to ensure interoperability.	See Before You Begin in <a href="#">Chapter 2, “Preparing for Your System Installation,”</a> and refer to the tasks that are described in the individual product installation documents.
<b>Step 7</b>	Perform postinstallation tasks.	See Postinstallation Tasks in <a href="#">Chapter 3, “Performing Your System Installation”</a> .

## Components Installation Overview

The Cisco Unified Communications contact center environment consists of four primary software components:

- Call processing infrastructure consisting of Cisco Unified Communications Manager components
- Contact center routing and agent management provided by Cisco Unified Contact Center Enterprise (Unified CCE), which is based on the Unified Intelligent Contact Management (Unified ICM) software that includes the CallRouter, Logger, and Peripheral Gateway components
- Queuing and self-service provided by either Cisco Customer Response Solutions (Cisco CRS, implemented as Unified IP Integrated Voice Response (Unified IP IVR)) or Unified Customer Voice Portal (Unified CVP)



**Note** Typically, in most contact center deployments, you need to install only one of these components for queuing and call treatment purposes. However, if you want to deploy a parent and child model, you will need to install both components.

- Agent desktop applications consisting of the Cisco Agent Desktop (CAD) or Cisco Telephony Integration Object Server (CTI OS) desktop software

In addition to these core components, the following Cisco hardware and software products are required for a complete contact center deployment:

- Cisco Unified IP Phones
- Cisco gateways and gatekeepers
- Cisco LAN/WAN infrastructure and components
- Cisco security components
- Network management tools

Table 1-2 provides an overview of primary components in the Cisco Unified Communications System Release 6.1(1) product family that can be installed and configured in contact center environments.



**Note** Some of the listed components might not apply to particular installations. Therefore, if there is an application, component, or feature listed that you do not require in your environment, you need not include them in your deployment.

**Table 1-2 Primary Contact Center Components in Cisco Unified Communications System**

Component/Application/Feature	Purpose
<b>Communications Infrastructure and Wireless Components</b>	
Switches and routers	Cisco switches and routers provide switching and intelligent routing services that can deliver voice, video, data and Internet access, wireless, and other applications and provide high-speed connectivity among users, applications, and communications systems.
Gateways and gatekeepers	Cisco gateways and gatekeepers are optimized for data, wireless, and IP Communications, and support IP-to-IP connectivity between independent voice-over-IP (VoIP) networks and analog phone gateways using your existing phone equipment.
Firewall and security components	Security components include firewall and policy enforcement services, antivirus software, and domain and web server hardening.  Firewall Services Module (FWSM) allows any port on the device to operate as a firewall port and integrates firewall security inside the network infrastructure.  Policy enforcement services can protect networks from unauthorized access. These services combine with VPN services to enable businesses to securely extend their networks to business partners, remote sites, and mobile workers.
Wireless components	Wireless components provide for secure, scalable, cost-effective WLANs with real-time access to instant messaging, e-mail, and network resources.

**Table 1-2 Primary Contact Center Components in Cisco Unified Communications System (continued)**

Component/Application/Feature	Purpose
Cisco Unified Presence (as SIP Proxy server)	Static routes are configured in Cisco Unified Presence to route incoming calls to Unified CVP from the gateway, to transfer calls to the VXML gateway, and to transfer calls to agent devices on Unified Communications Manager.  Cisco Unified Presence is added as a SIP Proxy server under Device Management in the Unified CVP Operations Console.
<b>Cisco Unified Communications Manager and Call Processing Devices</b>	
Cisco Unified Communications Manager	Unified Communications Manager provides the call-processing functionality to Cisco Unified Communications contact center networks.  <b>Note</b> Make sure that you obtain the required licenses to perform the installation.
Cisco Unified Communications Manager services	A variety of services must be activated on the publisher, subscribers, and TFTP servers that are essential for call processing in the Unified Communications Manager cluster.
Cisco Unified IP Phones (SIP and SCCP)	Use different methods like auto-registration and Bulk Administration Tool (BAT) to install and add Unified IP Phones to the Unified Communications Manager database.
Cisco IP Communicator	IP Communicator is a software-based application that delivers enhanced telephony support through the PC. It is designed to meet diverse customer needs by serving as a supplemental telephone when traveling, a telecommuting device, or as a primary desktop telephone.
Cisco Unified Communications Manager cluster (integration with switches, routers, gateways, gatekeepers, JTAPI client and Cisco Unified Communications Manager Telephony client and Unified ICM)	Install the JTAPI client on the Unified Communications Manager PGs and the Unified Communications Manager Telephony client on the CRS system to enable communication with the Unified Communications Manager cluster.  Configure dial plans, route points, groups, device parameters, and the JTAPI user to set up call processing and policy rules in Unified Communications Manager to enable interaction with switches, routers, gateways, gatekeepers and Unified ICM.
Unity Connection	Unity Connection combines voice messaging, integrated messaging, speech recognition capabilities, and call-routing rules into an easy-to-manage system for midsize organizations with up to 1,500 users.
<b>Cisco Unified Contact Center Enterprise and Contact Center Components</b>	
Cisco Unified Contact Center Enterprise software	Unified CCE combines Cisco's IP telephony products and Unified ICM software to create an IP-based contact management solution that provides intelligent call routing, network-to-desktop computer telephony integration (CTI), and multimedia contact management to contact center agents over an IP network.  <b>Note</b> You can install Unified CCE using either the legacy installation or the simplified installation (Cisco Unified System Contact Center (Unified SCC) implementation).
Cisco Unified Communications Manager (integration with Cisco Unified Contact Center Enterprise)	Unified Communications Manager provides call processing to the Unified CCE applications, but requires configuration changes to support Unified CCE such as CTI and JTAPI capabilities.



**Table 1-2 Primary Contact Center Components in Cisco Unified Communications System (continued)**

<b>Component/Application/Feature</b>	<b>Purpose</b>
Cisco Unified Intelligent Contact Management Enterprise software	<p>Unified ICM software provides the intelligence needed to make call-by-call routing decisions for your call center using a combination of multichannel contact management, intelligent routing, and network-to-desktop computer telephony integration (CTI) capabilities.</p> <p>This software includes the Rogger (CallRouter and Logger), Peripheral Gateways (Generic, Unified CCGE, and Unified SCCG), RT AW/Webview/HDS servers and Unified ICM Support Tools.</p>
Cisco Unified Intelligent Contact Management Enterprise setup	Configure skill groups, device targets, labels, agents, scripts and others on Unified ICM to provide call routing capabilities.
Cisco Security Agent (on the Unified ICM server)	The agent provides intrusion detection and prevention for the Cisco Unified ICM server and controls system operations by using a policy that allows or denies specific system actions before system resources are accessed.
Computer Telephony Integration Object Server (CTI OS)	CTI OS is a server-based integration point for third-party applications and for deploying CTI applications that provide desktops for use by call center agents and supervisors. Configuration and behavior information is managed at the server, simplifying customization, updates, and maintenance.
Cisco Agent Desktop server	Cisco Agent Desktop is a computer telephony integration (CTI) solution that provides agents and supervisors call control capabilities, such as call answer, hold, conference, and transfer, and ACD state control and so on.
CTI OS and Cisco Agent and Supervisor Desktops	<p>CTI OS includes the CTI OS Server, CTI OS Agent/Supervisor Desktop, CTI OS Toolkit, and Client Interface Library (CIL).</p> <p>Cisco Agent/Supervisor Desktop includes the Desktop Administrator, Agent Desktop, and Supervisor Desktop.</p> <p>The desktop applications provide productivity tools for agents and supervisors. The desktop allows supervisors to view agent states and call information, to send text messages to agents, to record conversations, and to provide advanced monitoring functions. You can select which application to deploy in the Unified CCE system.</p>
Cisco Customer Response Solutions system	<p>Cisco CRS (Unified IP IVR) provides IP-based Interactive Voice Response (IVR) and queueing capabilities for the Unified CCE system.</p> <p><b>Note</b> Make sure you obtain the required licenses to perform the installation.</p>
Cisco Customer Response Solutions system setup	Configure media dialog groups, Unified Communications Manager Telephony connection, Unified ICM connection port, Voice Response Unit (VRU) scripts, applications, prompts and others on the CRS system to provide call routing capabilities.
Cisco Unified Customer Voice Portal system	<p>Unified CVP provides a call-management and call-treatment solution with a self-service IVR option. Automated speech recognition (ASR) and text-to-speech (TTS) capabilities enable callers to obtain personalized information and conduct business without interacting with a live agent.</p> <p><b>Note</b> Make sure you obtain the required licenses to perform the installation.</p>
Cisco Security Agent (on the Unified CVP and Cisco CRS systems)	The agent provides intrusion detection and prevention for the servers and controls system operations by using a policy that allows or denies specific system actions before system resources are accessed.

**Table 1-2 Primary Contact Center Components in Cisco Unified Communications System (continued)**

Component/Application/Feature	Purpose
Cisco Unified CVP (integration with Cisco Unified Presence)	Cisco Unified Presence is added as a SIP Proxy Server under Device Management in the Unified CVP Operations Console. Static routes are configured in Cisco Unified Presence to route incoming calls to Unified CVP from the gateway, to transfer calls to the VXML gateway, and to transfer calls to agent devices on Unified Communications Manager.
Cisco Unified Outbound Dialer	Unified OUTD provides outbound dialing functionality that can be “blended” with the existing inbound capabilities of Unified ICM software. Related components that require installing and configuring include the Unified Outbound Campaign Manager and Media Routing Peripheral Gateway (MRPG).
Supervisors and agents setup	This enables Unified Communications Manager, Unified ICM and gateways to route calls to the different types of supervisors and agents within and outside the contact center environment such as CAD, CTI OS, Remote Agents and Cisco Unified Mobile Agents.
Cisco Unified Operations Manager	Unified Operations Manager provides comprehensive monitoring and diagnostics for the entire system. It performs automatic discovery of the entire system and provides contextual diagnostics for rapid troubleshooting.

## System Installation Strategies

This section discusses the installation strategies for contact center components in the release set being deployed. Details of individual components installations are not described unless additional information or clarification is required.

Installation of new networks in Cisco Unified Communications contact center environments (using new hardware) is supported via a *flash-cut* or a *shrink-and-grow* approach.

### Single-Stage Installation Using New Hardware (for Greenfield Deployments)

A completely new network is built using the components and software versions in the current Cisco Unified Communications System release set. The new system is operational once it is turned on and the required software is installed and initial configuration is completed.

### Single-Stage Installation Using New Hardware (for Legacy Deployments)

A new network using the components and software versions in the current Cisco Unified Communications System release set is built alongside the legacy network. The new network is staged and configured to support the production environment.

In this strategy, you can implement the release versions on the new hardware and migrate all users from the existing legacy network to the new network in a single installation window using a flash-cut installation process.

Because interoperability is not required with the legacy system, components of the legacy system need not be upgraded and can remain at their original release versions. After all users have been moved to the newly installed system, the legacy system is decommissioned.

## Multistage Installation using New Hardware (for Legacy Deployments)

A new network using the components and software versions in the current Cisco Unified Communications System release set is built alongside the legacy network. The new network is staged and configured to support the production environment.

This strategy uses either a flash-cut or shrink-and-grow installation process or a combination of both to:

- Deploy all the applications in one installation window (flash-cut) or in several installation windows (shrink-and-grow).
- Migrate all the users in one installation window (flash-cut) or in multiple installation windows (shrink-and-grow).

After all users have been moved to the newly installed system, the legacy system is decommissioned.

## Multisite Phased Installation

For large enterprises with many sites, you can install one site at a time in multiple phases. Depending on whether it is a greenfield or legacy deployment, within each site, you can either employ the single-stage or multistage installation strategies described in this section.

## Interoperability and Compatibility Portals

For information about support for legacy products and third-party product interoperability with Cisco Unified Communications contact center products, see the Cisco Interoperability Portal at:

[www.cisco.com/go/interoperability](http://www.cisco.com/go/interoperability)

For compatibility and interoperability information about Unified Communications Manager, Unified Contact Center Enterprise, CRS and other Cisco Unified Communications contact center products, see the following sites:

- Cisco Unified Communications Compatibility Tool:  
<http://tools.cisco.com/ITDIT/vtgsc>
- *IPCC Enterprise Software Compatibility Guide*:  
[http://cisco.com/en/US/docs/voice\\_ip\\_comm/cust\\_contact/contact\\_center/ipcc\\_enterprise/ipccenterprise7\\_2/design/guide/IPCC\\_Compatibility\\_MATRIX\\_6\\_6\\_07.pdf](http://cisco.com/en/US/docs/voice_ip_comm/cust_contact/contact_center/ipcc_enterprise/ipccenterprise7_2/design/guide/IPCC_Compatibility_MATRIX_6_6_07.pdf)
- *Cisco Response Solutions (CRS) Software and Hardware Compatibility Guide*:  
[http://www.cisco.com/univercd/cc/td/doc/product/voice/sw\\_ap\\_to/crscomtx.pdf](http://www.cisco.com/univercd/cc/td/doc/product/voice/sw_ap_to/crscomtx.pdf)
- Cisco Computer Telephony Integration Option: CTI Compatibility Matrix:  
[http://www.cisco.com/en/US/products/sw/custcosw/ps14/prod\\_technical\\_reference\\_list.html](http://www.cisco.com/en/US/products/sw/custcosw/ps14/prod_technical_reference_list.html)
- Cisco Unified Communications System Release Summary Matrix for Contact Center:  
<http://www.cisco.com/univercd/cc/td/doc/systems/unified/ccmtrix.htm>
- IP Communications System Test Release Matrix:  
[http://www.cisco.com/univercd/cc/td/doc/product/voice/ip\\_tele/gblink/ipcmtrix.htm](http://www.cisco.com/univercd/cc/td/doc/product/voice/ip_tele/gblink/ipcmtrix.htm)





## CHAPTER 2

# Preparing for Your System Installation

---

This topic provides information that you should review before the actual installation process such as the general installation approach, release set software and firmware versions of the contact center components being installed, and dependencies impacting system installation.

This topic contains the following sections:

- [Before You Begin](#)
- [System Installation Approach](#)
- [Release Set Versions](#)
- [System Installation Dependencies](#)



### Note

---

Many of the contact center component names have changed as part of Cisco Unified Communications System releases. Only the latest product names are used in this document, even when referencing products from previous releases.

---

## Before You Begin

Before you install and configure the Cisco Unified Communications contact center family of products, make sure that you have performed the required planning, design and implementation activities that are part of the Cisco Systems product deployment and lifecycle model.



### Note

---

See the Cisco Unified Communications System Technical Information Site at <http://www.cisco.com/go/unified-techinfo> for comprehensive system-level deployment and lifecycle model information.

---

This section lists some, but not all, of the required planning, design and implementation activities:

#### Prepare and Plan Phase

- Review preinstallation planning guidelines from Steps to Success at: <http://www.cisco.com/web/partners/support/steps-to-success/index.html>
- Assess your business and technical requirements such as call flows, capacity and critical features, and incumbent dependencies.
- Consider integration for legacy and third-party products (see System Installation Overview in Chapter 1, “[Planning Your System Installation](#)”).

- Assess system passwords requirements and create a password synchronization and maintenance strategy.
- Assess your services and support strategy for training and lifecycle support.

### Design Phase

- Develop a high-level and low-level design including product and component selections appropriate for your needs.
- Use the recommendations of the Cisco Solution Reference Network Design (SRND) documents at: <http://www.cisco.com/go/srnd>
- Review system description, architecture, and testing information for contact center systems at: <http://www.cisco.com/cisco/web/docs/iam/unified/ipcc611/index.html>



#### Note

---

The results derived from conducting the tasks in the prepare, plan, and design phases indicate which Cisco Unified Communications System components apply to your business requirements and should be part of your overall deployment.

---

### Implement Phase

- Confirm the design and special feature considerations developed during the design phase.
- Develop an implementation plan and a migration or integration strategy.



#### Note

---

The implementation plan derived from the implement phase should drive the staging, phases and deadlines of the system installation.

---

- Review preinstallation and planning documents such as site surveys, equipment lists, and product-specific documents.
- Conduct hardware installation and verification tasks at each site such as:
  - Catalog and inventory the equipment.
  - Install equipment in data racks.
  - Complete cabling and other physical connectivity tasks.
  - Verify all units power up correctly.
  - Capture rack layout, cabling, port-specific details, and so on.
- Conduct software installation and verification tasks at each site such as:
  - Check that all the required installation discs are available for each system component being installed.
  - Check that all the required installation discs are available for software applications, including third-party applications.
  - Access and download the license files required to install and operate the appropriate software at: <http://www.cisco.com/go/license>

# System Installation Approach

After you perform preinstallation tasks, install each Cisco Unified Communications Manager (formerly known as Cisco Unified CallManager) cluster and its associated contact center components at one time, before installing the next cluster.

The installation sequence of the contact center components should also be dictated by the following considerations:

- The relative importance of the service that these components provide. For example, basic phone service is considered to be of greater importance than supplementary services or voice messaging services.
- Integration and configuration of the system components to ensure interoperability.

[Table 2-1](#) provides the general approach to installing a contact center environment.

**Table 2-1 System Installation General Sequence**

	Procedure	Remarks
<b>Step 1</b>	Install and configure network infrastructure such as switches and routers, wireless, and security components.	These components should be installed first to ensure that the infrastructure is able to support the services that the Cisco Unified Communications System components required.
<b>Step 2</b>	Install the operating system on system servers and install and configure directory and network services.	These services include LDAP, DNS, NTP, and DHCP servers.
<b>Step 3</b>	Install call processing components such as Unified Communications Manager clusters.	Make sure that you complete all initial setup and configuration procedures that are required.
<b>Step 4</b>	Install and configure the contact center components based on your requirements and the interdependencies of components.	See <a href="#">System Installation Dependencies</a> for information.
<b>Step 5</b>	Install and configure gateways, gatekeepers, network management tools, and other third-party services and applications.	—
<b>Step 6</b>	Complete postinstallation tasks.	These tasks include system validation and verification.

## Release Set Versions

This section provides the software versions of the Cisco Unified Communications System Release 6.1(1) contact center components. It contains the following sections:

- [Software Version Matrix](#)
- [System Installation Dependencies](#)

## Software Version Matrix

Table 2 lists the release versions of the Cisco Unified Communications System Release 6.1(1) components in the contact center test environment.

**Table 2** *Software Versions for Contact Center Components in Cisco Unified Communications System Release 6.1(1)*

Category	Component	Release Version
Call Control	Cisco Unified Communications Manager <sup>1</sup>	6.1(1a)
	Cisco Unified Presence <sup>1</sup>	6.0(2)
Contact Center	Cisco Unified Intelligent Contact Management and Cisco Unified Contact Center Enterprise	7.2(2)
	Cisco Unified Intelligent Contact Management and Cisco Unified Contact Center Enterprise Operating System	Win2003 SP2/ Win2003 R2 SP2
	Cisco Unified ICM Support Tools (Server and Agent)	2.2(1)
	Cisco Customer Response Solutions (Unified IP IVR)	5.0(2)
	Cisco Customer Response Solutions (Unified IP IVR) Operating System	2003.1.2a SR5
	Cisco Unified Customer Voice Portal	4.0(2) <sup>2</sup>
	Cisco Unified Customer Voice Portal Operating System	Win2003 SP2/ Win2003 R2 SP2
Voice Mail and Unified Messaging	Cisco Unity Connection	2.0
End Points and Clients	Cisco IP Communicator	2.1(1)
	Cisco Unified IP Phones (7921 (Wireless), 7940, 7940G, 7960, 7960G, 7962, 7970, and 7970G)	Bundled with Unified Communications Manager
Network Management	Cisco Unified Operations Manager	2.0.2
Security	Cisco Catalyst 6500 Series Switch Firewall Services Module (FWSM)	3.2(2)
	Cisco Adaptive Security Appliance (ASA) 5540 Services	8.0(3)
	CiscoWorks Management Center for Cisco Security Agents	5.0.0.216
	Cisco Security Agent for Unified Communications Manager	Bundled with Unified Communications Manager
	Cisco Security Agent for Customer Response Solutions	5.0.0.217-3.0.6
	Cisco Security Agent for Unified Intelligent Contact Management	5.0.0.210-3.0.1
	Cisco Security Agent for Unified Customer Voice Portal	5.2.0.203-2.2.1



**Table 2** *Software Versions for Contact Center Components in Cisco Unified Communications System Release 6.1(1) (continued)*

Category	Component	Release Version
Communications Infrastructure	Cisco 3725, 3745 (Unified CVP VXML, voice/data, H.323, SIP, and MGCP gateways)	12.4(15)T3
	Cisco 3825, 3845 (Unified CVP VXML, voice/data, H.323, SIP, and MGCP gateways)	12.4(15)T3
	Cisco AS5400HPX, AS5400XM (Unified CVP VXML, voice, H.323, and PSTN gateways)	12.4(15)T3
	Cisco AS5850 (PSTN and voice gateway)	12.4(15)T3
	Cisco 3745 (gatekeeper)	12.4(15)T3
	RSVP Agent (on 37xx and 38xx platforms)	12.4(15)T3
	Cisco 7206 (core/WAN router)	12.4(15)T3
	Cisco 871 router	12.3(8)Y12
	Cisco Catalyst 3750 (access switch)	12.2(25)SEE2
	Cisco Catalyst 6506, 6509 (core switch, Supervisor 2)	CatOS 8.5(8)
	Cisco Catalyst 6506, 6509 (MSFC, Supervisor 2)	12.2(18)SXF8
	Cisco Catalyst 6506, 6509 (Supervisor 720)	12.2(18)SXF8
	Cisco CSS 11501 Content Services Switch	WebNs 7.50.3.3
	Cisco Communication Media Module (CMM)	12.4(15)T3
	Wireless	Cisco Aironet Access Point 1240AG
Third-Party Products	McAfee Antivirus	Enterprise 8.0.0 Patch Version: 11

1. For important information on servers on which the component software is running, see *System Release Notes for Contact Center: Cisco Unified Communications System Release 6.1(1)* at: <http://www.cisco.com/univercd/cc/td/doc/systems/unified/uc611/relnotes/rnipc611.htm>.
2. For important information on engineering specials associated with Unified CVP Release 4.0(2), see *System Release Notes for Contact Center: Cisco Unified Communications System Release 6.1(1)* at: <http://www.cisco.com/univercd/cc/td/doc/systems/unified/uc611/relnotes/rnipc611.htm>.

# System Installation Dependencies

The components within each release set are compatible with each other and will interoperate correctly. As you install individual components of the integrated system, the overall system may not be operational until all components have been installed or some initial configuration or setup is completed to ensure that the already installed components will interoperate with the newly installed component.



## CHAPTER 3

# Performing Your System Installation

---

This topic provides guidance for the installation order of components for a Cisco Unified Communications System Release 6.1(1) contact center deployment. This information is to be used with the information from the planning and design phases as input to the implementation plan. The implementation plan drives the staging, phases and deadlines of the system installation.

This document does not describe installation procedures for individual components. This information is included in the installation documents for the components. See [Related Documentation](#) for references to these documents.

This topic contains the following sections:

- [Deployment Models](#)
- [Installing Components](#)
- [Postinstallation Tasks](#)
- [Related Documentation](#)



### Note

---

Many of the contact center component names have changed as part of Cisco Unified Communications System releases. Only the latest product names are used in this document, even when referencing products from previous releases.

---

## Deployment Models

This section describes the general order of installation for each Cisco Unified Communications System deployment model. Because each model can include different components, compare these deployments to your deployment to best understand the installation process that is applicable in your environment.

The following sections list the installation sequence of components in the various deployment models in the Cisco Unified Communications contact center test environment:

- [Single-Site Model](#)
- [Multisite Centralized Model](#)
- [Multisite Distributed Model](#)
- [Clustering over the WAN Model](#)

Detailed information about these contact center deployment models at different sites is available at [http://www.cisco.com/cisco/web/docs/iam/unified/ipcc611/Review\\_Testing\\_Deployment\\_Models.html](http://www.cisco.com/cisco/web/docs/iam/unified/ipcc611/Review_Testing_Deployment_Models.html) and in the following documents:

- *System Description: Cisco Unified Communications Release 6.1(1)* at:  
<http://www.cisco.com/univercd/cc/td/doc/systems/unified/uc611/sysdesc/index.htm>
- *Solution Reference Network Design (SRND) for Cisco Unified Contact Center Enterprise, Releases 7.x* at:  
[http://www.cisco.com/en/US/products/sw/custcosw/ps1844/products\\_implementation\\_design\\_guide\\_book09186a008057a473.html](http://www.cisco.com/en/US/products/sw/custcosw/ps1844/products_implementation_design_guide_book09186a008057a473.html)

After you determine the general installation sequence, use one of the installation strategies that is described in [Installing Components](#) to install your components.

## Single-Site Model

A single-site deployment refers to any scenario where all voice gateways, agents, desktops, phones, and call processing servers (Cisco Unified Communications Manager (formerly known as Unified CallManager), Unified ICM/Unified CCE, and Unified IP IVR or Cisco Unified CVP) are located at the same site and have no WAN connectivity between any Unified CCE software modules.

In the single-site model, install the components in the following order:

1. Infrastructure components such as:
  - Core and access switches and routers
  - Cisco Unified Presence (as a SIP Proxy Server for Unified CVP implementation)
  - Security components
  - Wireless Access Point(s)
2. Directory and network service components such as:
  - Domain Controllers (including Active Directory)
  - LDAP Directory
  - NTP Server
  - DHCP Server
  - DNS Server
  - TFTP Server
3. Call processing components such as:
  - Cisco Unified Communications Manager (Cisco Unified IP Phones are installed at the same time)
  - Cisco IP Communicator
4. Messaging components such as:
  - Cisco Unity Connection
  - Voice Recognition Server (optional)
5. Media resources such as:
  - Conference bridges
  - Transcoders

- Music-On-Hold servers
  - Media termination points
  - RSVP Agents
6. Contact center components such as:
    - Cisco Unified ICM system (CallRouter, Logger, Peripheral Gateway, CTI OS and Cisco Agent Desktop (CAD) servers)
    - Real-time Administration Workstation (at least one)
    - Cisco Unified Outbound Dialer
    - CTI OS Agent and Supervisor Desktop
    - Cisco Agent Desktop (CAD) and Cisco Supervisor Desktop (CSD)
    - VoIP Monitor
    - Cisco Unified Customer Voice Portal Voice Browser/Application Server/HTTP Media Server or CRS (Cisco Unified IP IVR)
  7. Voice and data gateways and gatekeepers
  8. Network management tools (such as Cisco Unified Operations Manager)
  9. Cisco applications coresident on MCS servers (such as Cisco Security Agent, JTAPI software)
  10. Third-party on-board agents on MCS servers (such as antivirus, backup agent, management agent (SNMP))



---

**Note** For Unified Communications Manager Release 6.1(1a), third-party on-board agents must be installed on a separate MCS server.

---

11. Cisco and third-party adjunct applications or endpoints on other servers

## Multisite Centralized Model

A multi-site deployment with centralized call processing refers to any scenario where call processing servers (Unified Communications Manager, Unified ICM, and Unified IP IVR or Unified CVP) are located at the same site, while any combination of voice gateways, agents, desktops, and phones are located remotely across a WAN link or centrally.

In the multisite centralized model, install the central site first and then install the remote sites.

### Central Site

In the central site, install the components in the following order:

1. Infrastructure components such as:
  - Core and access switches and routers
  - IOS Gatekeepers
  - Cisco Unified Presence (as a SIP Proxy Server for Unified CVP implementation)
  - Security components
  - Wireless Access Point(s)

2. Directory and network service components such as:
  - Domain Controllers (including Active Directory)
  - LDAP Directory
  - NTP Server
  - DHCP Server
  - DNS Server
  - TFTP Server
3. Call processing components such as:
  - Cisco Unified Communications Manager (Cisco Unified IP Phones are installed at the same time)
  - Cisco IP Communicator
4. Messaging components such as:
  - Cisco Unity Connection
5. Media resources such as:
  - Conference bridges
  - Transcoders
  - Music-On-Hold servers
  - Media termination points
  - RSVP Agents
6. Contact center components such as:
  - Cisco Unified ICM components (CallRouter, Logger and Peripheral Gateway)
  - Real-time Administration Workstation (at least one)
  - Cisco Unified System Contact Center Gateway (Unified SCCG) and Cisco Unified Contact Center Gateway Enterprise (Unified CCGE)
  - CTI OS and Cisco Agent Desktop (CAD) servers
  - Cisco Unified Outbound Dialer
  - CTI OS Agent and Supervisor Desktop
  - Cisco Agent Desktop (CAD) and Cisco Supervisor Desktop (CSD)
  - VoIP Monitor
  - Cisco Unified Customer Voice Portal Voice Browser/Application Server/HTTP Media Server or CRS (Cisco Unified IP IVR)
7. Voice and data gateways and gatekeepers
8. Network management tools (such as Cisco Unified Operations Manager)
9. Cisco applications coresident on MCS servers (such as Cisco Security Agents, JTAPI software)
10. Third-party on-board agents on MCS servers (such as antivirus, backup agent, management agent (SNMP))



---

**Note** For Unified Communications Manager Release 6.1(1a), third-party on-board agents must be installed on a separate MCS server.

---

11. Cisco and third-party adjunct applications or endpoints on other servers

#### Remote Site

For the remote site(s), install the components in the following order:

1. Infrastructure components such as:
  - Core and access switches and routers
  - Voice and data gateways
  - Security components
  - Wireless Access Point(s)
2. Cisco Unified IP Phones
3. CTI OS Agent and Supervisor Desktop
4. Cisco Agent Desktop (CAD) and Cisco Supervisor Desktop (CSD)

## Multisite Distributed Model

In this model, each site has its own Unified Communications Manager cluster, treatment and queue points, Peripheral Gateways, and CTI Server. However, as with the centralized call processing model, sites could be deployed with or without local voice gateways. Some deployments may also contain a combination of distributed voice gateways (possibly for locally dialed calls) and centralized voice gateways (possibly for toll-free calls) as well as centralized or distributed treatment and queue points. The multisite distributed model includes several Unified CCE and Unified Communications Manager cluster sites interconnected by ICT or H.323 trunks.

Install the components in each cluster site and any small remote sites as listed in the [Multisite Centralized Model](#) section.



#### Note

---

The installation of each cluster site should be treated as a separate stage in the overall system installation.

---

## Clustering over the WAN Model

In the Clustering over the WAN (CoW) model, a single Unified Communications Manager cluster with its subscriber servers and Unified CCE components are split across multiple sites connected via a QoS-enabled WAN. This model provides the redundancy of the distributed model with the simplicity of administering a single Unified Communications Manager cluster and Unified CCE installation.

Install the central sites first where CoW is implemented and then install any remote sites as listed in the [Multisite Centralized Model](#) section.



#### Note

---

Install clustered components in the same installation period and stage at each of the central sites.

---

# Installing Components

After you review the general install sequence for your specific deployment model, install your components based on the following installation strategies:

- **Single-Stage Installation**—Recommended for small single-site and multisite deployments.
- **Multistage System Installation**—Recommended for medium and large single-site and medium multisite deployments.
- **Multisite Phased installation**—To install large, multisite contact center deployments to the Cisco Unified Communications release set using the multisite phased installation strategy, you can use either the single-stage or multistage system installation information listed in this section.

See [Chapter 1, “Planning Your System Installation”](#) for additional information about the above installation strategies and [Chapter 2, “Preparing for Your System Installation”](#) for the software release versions of the components in the release set being installed.



## Note

After you install the system software and applications, you may also need to install client software such as Cisco IP Communicator, CTI OS and CAD desktop software, and others, on the client desktops.

To install each component, see the product-specific installation document for detailed information. See [Related Documentation](#) for a list of this documentation.

## Single-Stage Installation

The single-stage installation process is recommended for small single-site and multisite installations and can be performed in a single installation window.

[Table 3-1](#) lists the recommended order in which to install components. See [Chapter 2, “Preparing for Your System Installation”](#) for the software release versions of the components in the release set being installed.

**Table 3-1** *Single-stage Installation Order for Contact Center Components*

Order	Components Being Installed
1	Switches and routers
2	Security components
3	Wireless components
4	Directory and network services
5	Call processing components
6	Media resources
7	Messaging components
8	Contact center routing components
9	Agent management components
10	Agent desktop client software
11	Queuing and self-service components <sup>1</sup>
12	Gatekeepers and voice and data gateways



**Table 3-1** *Single-stage Installation Order for Contact Center Components (continued)*

Order	Components Being Installed (continued)
13	Network management components
14	Cisco applications coresident on MCS servers
15	Third-party on-board agents on MCS servers <sup>2</sup>
16	Cisco and third-party applications on other servers

1. In most deployments, you need to install only one of these queuing and call treatment components. However, if you want to deploy a parent and child model, you should install both components.
2. For Unified Communications Manager Release 6.1(1a), third-party on-board agents must be installed on a separate MCS server.

## Multistage System Installation

A multistage system installation is the recommended approach for medium and large single-site and medium multisite installations. In this installation process, components are grouped together for installing in several stages or installation windows. Within each installation window, there is a recommended order for installing each component.

The grouping of the components into the stages may vary depending on the size of the networks being installed. For smaller networks, several separate installation windows may be collapsed into a single installation window. Additional stages may be necessary for larger sites.

After each installation window, we recommend that you verify that the operation of all basic and critical call types remains unaffected before you initiate the next installation stage listed in the table. We also recommend that you maintain a list to track the components that have been installed and the ones yet to be installed.

Table 3-2 lists the recommended order in which to install components in stages and the sequence within each stage. See Chapter 2, “Preparing for Your System Installation” for the software release versions of the components in the release set.

**Table 3-2** *Multistage System Installation Order for Contact Center Components*

Stage	Component Groupings	Installation Order of Components in Each Stage
1	Switches and Routers	<ol style="list-style-type: none"> <li>1. Core Switches</li> <li>2. Access Switches</li> </ol>
2	Security components	<ol style="list-style-type: none"> <li>1. Cisco Catalyst 6500 Series Switch Firewall Services Module (FWSM)</li> <li>2. Cisco Adaptive Security Appliance (ASA) 5540 Services</li> </ol>
3	Wireless components	<ol style="list-style-type: none"> <li>3. Cisco Aironet Access Point 1240AG</li> </ol>
4	Directory and network services	<ol style="list-style-type: none"> <li>1. Domain Controllers (including Active Directory)</li> <li>2. LDAP Directory</li> <li>3. NTP Server</li> <li>4. DHCP Server</li> <li>5. DNS Server</li> <li>6. TFTP Server</li> </ol>

**Table 3-2 Multistage System Installation Order for Contact Center Components (continued)**

Stage	Component Groupings	Installation Order of Components in Each Stage
5	Call processing components	<ol style="list-style-type: none"> <li>1. Cisco Unified Communications Manager cluster (Cisco Unified IP Phones are installed along with the cluster)</li> <li>2. Cisco IP Communicator</li> </ol>
6	Media resources	<ol style="list-style-type: none"> <li>1. Conference bridges</li> <li>2. Transcoders</li> <li>3. Music-On-Hold servers</li> <li>4. Media termination points</li> <li>5. RSVP Agents</li> </ol>
7	Messaging components	<ol style="list-style-type: none"> <li>1. Cisco Unity Connection</li> </ol>
8	Contact center routing components	<ol style="list-style-type: none"> <li>1. Real Time AW/HDS/Webview</li> <li>2. Cisco Unified ICM Progger / Rogger</li> <li>3. Peripheral Gateway, Unified SCCG, Unified CCGE</li> </ol>
9	Agent management components	<ol style="list-style-type: none"> <li>1. CTI OS Server</li> <li>2. CAD Server</li> <li>3. Cisco Unified Outbound Dialer</li> </ol>
10	Agent desktop client software	<ol style="list-style-type: none"> <li>1. CTI OS Agent/Supervisor Desktop</li> <li>2. CAD Agent/Supervisor Desktop</li> </ol>
11	Queuing and self-service components <sup>1</sup>	<ol style="list-style-type: none"> <li>1. Cisco Unified Customer Voice Portal Voice Browser/Application Server/HTTP Media Server -or-</li> <li>2. CRS (Unified IP IVR)</li> </ol>
12	Gatekeepers and voice and data gateways	<ol style="list-style-type: none"> <li>1. IOS Gateways (SIP, MGCP and H.323)</li> <li>2. Cisco Unified Customer Voice Portal VXML Gateway</li> <li>3. IOS Gatekeepers</li> <li>4. Cisco Unified Presence (as SIP Proxy for Unified CVP)</li> </ol>
13	Network management components	<ol style="list-style-type: none"> <li>1. Cisco Unified Operations Manager</li> </ol>
14	Cisco applications coresident on MCS servers	<ol style="list-style-type: none"> <li>1. Depends on the applications being upgraded</li> </ol>
15	Third-party on-board agents on MCS servers <sup>2</sup>	<ol style="list-style-type: none"> <li>1. Depends on the applications being upgraded</li> </ol>
16	Cisco and third-party applications on other servers	<ol style="list-style-type: none"> <li>1. Depends on the applications being upgraded</li> </ol>

1. In most deployments, you need to install only one of these queuing and call treatment components. However, if you want to deploy a parent and child model, you should install both components.

2. For Unified Communications Manager Release 6.1(1a), third-party on-board agents must be installed on a separate MCS server.

# Postinstallation Tasks

After you complete the tasks in the implement phase and install the contact center components in the Cisco Unified Communications System release set, be aware of the following postinstallation phases and related tasks.

**Note**

---

See the Cisco Unified Communications System Technical Information Site at <http://www.cisco.com/go/unified-techinfo> for comprehensive system-level deployment and lifecycle model information.

---

**Operate Phase**

Ensure that the newly-installed contact center system is fully operational by performing tasks that include the following:

- Manage the newly installed network by conducting:
  - Fault and performance management at the platform level—Use the Real-Time Monitoring Tool (RTMT), which is a client application, to monitor CPU, memory, disk space, processes, and critical services.
  - Network management at the system level—Use Unified Operations Manager to perform SNMP/HTTP/syslog monitoring, track device and inventory status, and monitor logical relationships and physical connectivity in the network.
- Conduct Day 1 operations (cutover to customer) tasks such as:
  - Train administrators to support end-users to use the newly installed contact center system.
  - Provide documentation including as-builts, equipment inventory lists, topology diagrams, and unique design or feature considerations.
  - Explain the engagement process with Technical Assistance Center (TAC) support and the tasks to perform before contacting TAC.
- Conduct Day 2 operations (post-cutover) tasks such as:
  - Enforce security with the appropriate anti-virus security software, where applicable.
  - Provision for system password synchronization and maintenance.
  - Implement data backup and restore. For more information, see Backing up and Restoring Components at:  
[http://www.cisco.com/cisco/web/docs/iam/unified/ipcc611/Backing\\_Up\\_and\\_Restoring\\_Components.html](http://www.cisco.com/cisco/web/docs/iam/unified/ipcc611/Backing_Up_and_Restoring_Components.html)
  - Plan for release set management and system and security patches updates.

**Optimize Phase**

During this phase, perform system optimization tasks such as:

- Tune and resize the network for better performance
- Perform configuration cleanup procedures such as deleting user IDs that are no longer in use.
- Set trace logs and reporting levels to ensure optimal performance.

## Related Documentation

The following sections list compatibility guides and installation documentation for Cisco Unified Communications System components:

- [Compatibility Guides](#)
- [Component Release Notes and Installation and Upgrade Documents](#)

For information about support for legacy products and third-party product interoperability with Cisco Unified Communications contact center products, see the Cisco Interoperability Portal at:

[www.cisco.com/go/interoperability](http://www.cisco.com/go/interoperability)

## Compatibility Guides

For compatibility and interoperability information about Unified Communications Manager, Unified Contact Center Enterprise, CRS and other Cisco Unified Communications contact center products, see the following sites:

- Cisco Unified Communications Compatibility Tool:  
<http://tools.cisco.com/ITDIT/vtgsca>
- *IPCC Enterprise Software Compatibility Guide*:  
[http://www.cisco.com/application/pdf/en/us/guest/products/ps1844/c1609/ccmigration\\_09186a008031a0a7.pdf](http://www.cisco.com/application/pdf/en/us/guest/products/ps1844/c1609/ccmigration_09186a008031a0a7.pdf)
- *Cisco Response Solutions (CRS) Software and Hardware Compatibility Guide*:  
[http://www.cisco.com/univercd/cc/td/doc/product/voice/sw\\_ap\\_to/crscomtx.pdf](http://www.cisco.com/univercd/cc/td/doc/product/voice/sw_ap_to/crscomtx.pdf)
- Cisco Computer Telephony Integration Option: CTI Compatibility Matrix:  
[http://www.cisco.com/en/US/products/sw/custcosw/ps14/prod\\_technical\\_reference\\_list.html](http://www.cisco.com/en/US/products/sw/custcosw/ps14/prod_technical_reference_list.html)

## Component Release Notes and Installation and Upgrade Documents

Table 3-3 provides a listing of contact center components and URLs for related component release notes and installation and upgrade documents.

**Table 3-3** *Component-Specific Release Notes and Installation and Upgrade Documents*

Components	Release Notes	Installation and Upgrade Documents
Cisco Unified Communications Manager	<a href="http://www.cisco.com/en/US/products/sw/voicew/ps556/prod_release_notes_list.html">http://www.cisco.com/en/US/products/sw/voicew/ps556/prod_release_notes_list.html</a>	<a href="http://www.cisco.com/en/US/products/sw/voicew/ps556/prod_installation_guides_list.html">http://www.cisco.com/en/US/products/sw/voicew/ps556/prod_installation_guides_list.html</a>
Cisco Unified Intelligent Contact Management	<a href="http://www.cisco.com/en/US/products/sw/custcosw/ps1001/prod_release_notes_list.html">http://www.cisco.com/en/US/products/sw/custcosw/ps1001/prod_release_notes_list.html</a>	<a href="http://www.cisco.com/en/US/products/sw/custcosw/ps1001/prod_installation_guides_list.html">http://www.cisco.com/en/US/products/sw/custcosw/ps1001/prod_installation_guides_list.html</a>
Cisco Unified Contact Center Enterprise	<a href="http://www.cisco.com/en/US/products/sw/custcosw/ps1844/prod_release_notes_list.html">http://www.cisco.com/en/US/products/sw/custcosw/ps1844/prod_release_notes_list.html</a>	<a href="http://www.cisco.com/en/US/products/sw/custcosw/ps1844/prod_installation_guides_list.html">http://www.cisco.com/en/US/products/sw/custcosw/ps1844/prod_installation_guides_list.html</a>
CRS (Cisco Unified IP IVR)	<a href="http://www.cisco.com/en/US/products/sw/custcosw/ps1846/prod_release_notes_list.html">http://www.cisco.com/en/US/products/sw/custcosw/ps1846/prod_release_notes_list.html</a>	<a href="http://www.cisco.com/en/US/products/sw/custcosw/ps1846/prod_installation_guides_list.html">http://www.cisco.com/en/US/products/sw/custcosw/ps1846/prod_installation_guides_list.html</a>

**Table 3-3** Component-Specific Release Notes and Installation and Upgrade Documents

Components	Release Notes	Installation and Upgrade Documents
Cisco Customer Voice Portal	<a href="http://www.cisco.com/en/US/products/sw/custcosw/ps1006/prod_release_notes_list.html">http://www.cisco.com/en/US/products/sw/custcosw/ps1006/prod_release_notes_list.html</a>	<a href="http://www.cisco.com/en/US/products/sw/custcosw/ps1006/prod_installation_guides_list.html">http://www.cisco.com/en/US/products/sw/custcosw/ps1006/prod_installation_guides_list.html</a>
Cisco Unified Outbound Dialer	<a href="http://www.cisco.com/en/US/products/sw/custcosw/ps1001/prod_release_notes_list.html">http://www.cisco.com/en/US/products/sw/custcosw/ps1001/prod_release_notes_list.html</a>	<a href="http://www.cisco.com/en/US/products/sw/custcosw/ps524/prod_installation_guides_list.html">http://www.cisco.com/en/US/products/sw/custcosw/ps524/prod_installation_guides_list.html</a>
Cisco Telephony Integration Object Server (CTI OS)	<a href="http://www.cisco.com/en/US/products/sw/custcosw/ps14/prod_release_notes_list.html">http://www.cisco.com/en/US/products/sw/custcosw/ps14/prod_release_notes_list.html</a>	<a href="http://www.cisco.com/en/US/products/sw/custcosw/ps14/prod_installation_guides_list.html">http://www.cisco.com/en/US/products/sw/custcosw/ps14/prod_installation_guides_list.html</a>
Cisco Agent Desktop (CAD)	<a href="http://www.cisco.com/en/US/products/sw/custcosw/ps427/prod_release_notes_list.html">http://www.cisco.com/en/US/products/sw/custcosw/ps427/prod_release_notes_list.html</a>	<a href="http://www.cisco.com/en/US/products/sw/custcosw/ps427/prod_installation_guides_list.html">http://www.cisco.com/en/US/products/sw/custcosw/ps427/prod_installation_guides_list.html</a>
Cisco Unity Connection	<a href="http://www.cisco.com/en/US/products/ps6509/prod_release_notes_list.html">http://www.cisco.com/en/US/products/ps6509/prod_release_notes_list.html</a>	<a href="http://www.cisco.com/en/US/products/ps6509/prod_installation_guides_list.html">http://www.cisco.com/en/US/products/ps6509/prod_installation_guides_list.html</a>
Cisco IP Communicator	<a href="http://www.cisco.com/en/US/products/sw/voicesw/ps5475/prod_release_notes_list.html">http://www.cisco.com/en/US/products/sw/voicesw/ps5475/prod_release_notes_list.html</a>	—
Cisco Unified Operations Manager	<a href="http://www.cisco.com/en/US/products/ps6535/prod_release_notes_list.html">http://www.cisco.com/en/US/products/ps6535/prod_release_notes_list.html</a>	<a href="http://www.cisco.com/en/US/products/ps6535/prod_installation_guides_list.html">http://www.cisco.com/en/US/products/ps6535/prod_installation_guides_list.html</a>
Cisco Unified Presence	<a href="http://www.cisco.com/en/US/products/ps6837/prod_release_notes_list.html">http://www.cisco.com/en/US/products/ps6837/prod_release_notes_list.html</a>	<a href="http://www.cisco.com/en/US/products/ps6837/prod_installation_guides_list.html">http://www.cisco.com/en/US/products/ps6837/prod_installation_guides_list.html</a>
Cisco Series 800 Routers	<a href="http://www.cisco.com/en/US/products/hw/routers/ps380/prod_release_notes_list.html">http://www.cisco.com/en/US/products/hw/routers/ps380/prod_release_notes_list.html</a>	<a href="http://www.cisco.com/en/US/products/hw/routers/ps380/prod_installation_guides_list.html">http://www.cisco.com/en/US/products/hw/routers/ps380/prod_installation_guides_list.html</a>
Cisco Series 7200 Routers	<a href="http://www.cisco.com/en/US/products/hw/routers/ps341/prod_release_notes_list.html">http://www.cisco.com/en/US/products/hw/routers/ps341/prod_release_notes_list.html</a>	<a href="http://www.cisco.com/en/US/products/hw/routers/ps341/prod_installation_guides_list.html">http://www.cisco.com/en/US/products/hw/routers/ps341/prod_installation_guides_list.html</a>
Cisco Catalyst 3600 Series MultiService Platforms	—	<a href="http://www.cisco.com/en/US/products/hw/routers/ps274/prod_installation_guides_list.html">http://www.cisco.com/en/US/products/hw/routers/ps274/prod_installation_guides_list.html</a>
Cisco AS5400 Series Universal Gateways	<a href="http://www.cisco.com/en/US/products/hw/univgate/ps505/prod_release_notes_list.html">http://www.cisco.com/en/US/products/hw/univgate/ps505/prod_release_notes_list.html</a>	<a href="http://www.cisco.com/en/US/products/hw/univgate/ps505/prod_installation_guides_list.html">http://www.cisco.com/en/US/products/hw/univgate/ps505/prod_installation_guides_list.html</a>
Cisco AS5850 Series Universal Gateways	—	<a href="http://www.cisco.com/en/US/products/hw/univgate/ps509/prod_installation_guides_list.html">http://www.cisco.com/en/US/products/hw/univgate/ps509/prod_installation_guides_list.html</a>
Cisco 3700 Series Voice Gateways/Gatekeepers	<a href="http://www.cisco.com/en/US/products/hw/routers/ps282/prod_release_notes_list.html">http://www.cisco.com/en/US/products/hw/routers/ps282/prod_release_notes_list.html</a>	<a href="http://www.cisco.com/en/US/products/hw/routers/ps282/prod_installation_guides_list.html">http://www.cisco.com/en/US/products/hw/routers/ps282/prod_installation_guides_list.html</a>

**Table 3-3** *Component-Specific Release Notes and Installation and Upgrade Documents*

<b>Components</b>	<b>Release Notes</b>	<b>Installation and Upgrade Documents</b>
Cisco 3800 Series Voice Gateways	<a href="http://www.cisco.com/en/US/products/ps5855/prod_release_notes_list.html">http://www.cisco.com/en/US/products/ps5855/prod_release_notes_list.html</a>	<a href="http://www.cisco.com/en/US/products/ps5855/prod_installation_guides_list.html">http://www.cisco.com/en/US/products/ps5855/prod_installation_guides_list.html</a>
Cisco Catalyst 3550 Series Access Switches	<a href="http://www.cisco.com/en/US/products/hw/switches/ps646/prod_release_notes_list.html">http://www.cisco.com/en/US/products/hw/switches/ps646/prod_release_notes_list.html</a>	<a href="http://www.cisco.com/en/US/products/hw/switches/ps646/prod_installation_guides_list.html">http://www.cisco.com/en/US/products/hw/switches/ps646/prod_installation_guides_list.html</a>
Cisco Catalyst 6500 Series Switches	<a href="http://www.cisco.com/en/US/products/hw/switches/ps708/prod_release_notes_list.html">http://www.cisco.com/en/US/products/hw/switches/ps708/prod_release_notes_list.html</a>	<a href="http://www.cisco.com/en/US/products/hw/switches/ps708/prod_installation_guides_list.html">http://www.cisco.com/en/US/products/hw/switches/ps708/prod_installation_guides_list.html</a>
Cisco Unified IP Phone 7900 Series	<a href="http://www.cisco.com/en/US/products/hw/phones/ps379/prod_release_notes_list.html">http://www.cisco.com/en/US/products/hw/phones/ps379/prod_release_notes_list.html</a>	<a href="http://www.cisco.com/en/US/products/hw/switches/ps646/prod_installation_guides_list.html">http://www.cisco.com/en/US/products/hw/switches/ps646/prod_installation_guides_list.html</a>
Cisco Aironet Access Point 1240AG	<a href="http://www.cisco.com/en/US/products/ps6521/prod_release_notes_list.html">http://www.cisco.com/en/US/products/ps6521/prod_release_notes_list.html</a>	<a href="http://www.cisco.com/en/US/products/ps6521/prod_installation_guides_list.html">http://www.cisco.com/en/US/products/ps6521/prod_installation_guides_list.html</a>
Cisco IOS Software Release 12.4 T	<a href="http://www.cisco.com/en/US/products/ps6441/prod_release_notes_list.html">http://www.cisco.com/en/US/products/ps6441/prod_release_notes_list.html</a>	—



## **PART 2**

# **System Upgrade for Contact Center**







## CHAPTER 4

# Planning Your System Upgrade

---

This topic provides an overview of the upgrade process for contact center components, the software releases that are involved in the upgrade process, and the different upgrade strategies that can be used based on the size of the customer network.

This topic contains the following sections:

- [Cisco Unified Communications System Overview](#)
- [Release Sets](#)
- [Upgrade Roadmap](#)
- [Upgrade Overview](#)
- [System Upgrade Paths](#)
- [System Upgrade Strategies](#)



### Note

---

Many of the contact center component names have changed as part of Cisco Unified Communications System releases. Only the latest product names are used in this document, even when referencing products from previous releases.

---

## Cisco Unified Communications System Overview

The Cisco Unified Communications System is a full-featured business communications system built into an intelligent IP network. It enables voice, data, and video communications for businesses of all sizes. The Cisco Unified Communications System is defined around commonly deployed enterprise topology models in North America and European & Emerging Markets (EUEM).

Cisco Systems provides an integrated system to meet customer needs. The system contains a number of communications products that are designed, developed, tested, documented, sold, and supported as one entity. This system is built upon individual IP telephony and contact center products including, but not limited, to the Cisco Unified Communications Manager (formerly known as Cisco Unified CallManager), Cisco Unified Intelligent Contact Management (Unified ICM), Cisco Unified Customer Voice Portal (Unified CVP), Cisco Unified Contact Center Enterprise (Unified CCE), Cisco Customer Response Solutions (CRS), and voice-capable gateways and routers.

Cisco Unified Contact Center solutions allow you to move beyond today's contact center to a customer interaction network by creating a better customer experience, making customer-service agents more efficient and productive, improving contact center reporting, and extending the workforce with expert, mobile, and remote agents.

Cisco Unified Communications System testing is a process for specifying (designing) and validating the interoperability of enterprise voice products to ensure that they work together as an integrated system.

## Scope of this Upgrade Documentation

The upgrade process discussed for this Cisco Unified Communications System release addresses different upgrade paths and strategies, preparation for the upgrade operation, order of operations such as the sequence in which the contact center components should be upgraded, and other dependencies such as backward compatibility of software.

This topic only provides information related to upgrading components that are present in the base release set that is to be upgraded. See [Release Sets](#) for more information.

This topic does not provide installation, upgrade or backup procedures for:

- Components that are not part of the existing production network and are being newly added as a part of the target release. This information is available in the individual component documents.
- Individual standalone components such as Unified Communications Manager, Unified CCE, and Unified CVP. It only addresses the upgrade procedures of Cisco Unified Communications System components from a system-level perspective.

See Table 6-3 in [Chapter 6, “Performing Your System Upgrade”](#) for a list of URLs to component-specific release notes and installation and upgrade documents. When performing the actual component upgrades, see the product-specific upgrade documents for detailed information.

- Third-party co-resident applications (although they can be used during the upgrade and backup process) such as:
  - Antivirus
  - Security
  - Server management
  - Remote access
- Additional third-party off-board applications such as:
  - Operator console
  - VoIP recording
  - Billing and accounting
- Server replacement (hardware upgrade) for components. See the documentation for the individual components for this information.

## Release Sets

A release set is defined as the combination of products, components, and software versions that were tested to work together as an integrated Cisco Unified Communications system. A particular system release is also referred to as a release set.

A *base* release or release set is defined as the starting release set that is being upgraded. A *target* release or release set is defined as the ending release set to which the base release set is being upgraded.

The systems that are involved in the upgrade and discussed in this document include:

- Base release:
  - Cisco Unified Communications System Release 6.0(1)—Based on your specific environment, this release set may be the deployed software release that is being upgraded. For detailed information about the deployment models and topologies developed to test this release set, see [Review Tested Deployment Models for Contact Center](#).
- Target release:
  - Cisco Unified Communications System Release 6.1(1)—The new software release set that is the goal of the upgrade process, regardless of your base release set. For detailed information about the deployment models and topologies developed to test this release set, see [Review Tested Deployment Models for Contact Center](#).

For detailed information about the software versions of the components in the base and target release sets, see [Chapter 5, “Preparing for Your System Upgrade.”](#)

## Upgrade Roadmap

This section provides a roadmap of the high-level upgrade tasks:

- 
- Step 1** Review your hardware and software requirements. For instance, verify that the deployed hardware configurations and operating system support the target release and are ready for an upgrade.
- For a list of supported MCS servers for Unified Communications Manager 6.0, see the Cisco Unified Communications Manager Server Upgrade Program at:
- [http://www.cisco.com/en/US/products/hw/voiceapp/ps378/prod\\_brochure0900aecd8062a4f9.html](http://www.cisco.com/en/US/products/hw/voiceapp/ps378/prod_brochure0900aecd8062a4f9.html)
- Step 2** Perform all required hardware equipment checks. For instance, verify that the DVD ROM drive in the server where you plan to perform the upgrade tasks is operational before you start the upgrade process.
- Step 3** Upgrade the *existing* network components from the base release set to the target release set. For a list of existing components, see [Table 4-1](#).



---

**Note** The existing network should include components that are already supported by the base release set.

---

Use the recommended upgrade paths defined in [System Upgrade Paths](#) and the upgrade strategies described in [System Upgrade Strategies](#) to perform the upgrade. The upgrade paths and strategies you select should depend on a number of factors, such as:

- Base release set currently deployed in your network
  - Size of the network and number of sites
  - Topology of the network
  - Presence or absence of shared components among sites, for instance, a Unified ICM system that spans multiple clusters
- Step 4** Install any *new* components supported by the target release in the network and configure them. For a list of new components and their installation and configuration documents, see [New Components and Features in Target Release Set](#).

- Step 5** Remove and/or replace any components from your network that are not part of the target release or have reached EOL (end-of-life) and/or EOS (end-of-sale). Follow proper procedures to uninstall these components. For a list of components that should be removed/replaced, see [Components Not in Target Release Set](#).

**Note**

See the EOS and EOL website for a list of recommended replacements at: [http://www.cisco.com/en/US/products/prod\\_end\\_of\\_life.html](http://www.cisco.com/en/US/products/prod_end_of_life.html). For Cisco EOS and EOL policy, see the information at: [http://www.cisco.com/en/US/products/products\\_end-of-life\\_policy.html](http://www.cisco.com/en/US/products/products_end-of-life_policy.html).

## Upgrade Overview

This section lists the components included in the base release set involved in the upgrade process, the components that have to be newly installed for the target release set, and components that must be uninstalled because they are not part of the target release set.

This section includes:

- [Existing Components in Base Release Set](#)
- [New Components and Features in Target Release Set](#)
- [Components Not in Target Release Set](#)

## Existing Components in Base Release Set

[Table 4-1](#) contains a listing of components that are part of the base release set that is being upgraded to Cisco Unified Communications System Release 6.1(1),

**Table 4-1 Existing Contact Center Components in Base Release Set**

Component	Cisco Unified Communications System Release 6.0(1)
Cisco Unified Communications Manager	X
Cisco Customer Response Solutions (Unified IP IVR)	X
Cisco Unified Intelligent Contact Management and Cisco Unified Contact Center Enterprise	X
Cisco Unified Customer Voice Portal	X
Computer Telephony Integration Object Server (CTI OS)	X
Cisco Agent Desktop (CAD)	X
Nuance (Scansoft) Open Speech Recognizer (OSR)	X
Nuance (Scansoft) Open Speech Media Server (OSMS)	X
Nuance (Scansoft) Speechify	X
Cisco CSS 11501 Content Services Switch	X
Cisco Unity Connection	X

**Table 4-1 Existing Contact Center Components in Base Release Set (continued)**

Component	Cisco Unified Communications System Release 6.0(1)
Cisco IP Communicator	X
Cisco 3725, 3745 (Unified CVP VXML, voice/data, H.323, SIP and MGCP gateways)	X
Cisco 3825, 3845 (Unified CVP VXML, voice/data, H.323, SIP and MGCP gateways)	X
Cisco AS5400HPX, AS5400XM (Unified CVP VXML, voice, H.323 and PSTN gateways)	X
Cisco AS5850 (PSTN and voice gateways)	X
Cisco 3745 (gatekeeper)	X
RSVP Agent (on 37xx and 38xx platforms)	X
Cisco 7206 (core/WAN router)	X
Cisco 871 router	X
Cisco Catalyst 3750 (access switch)	X
Cisco Catalyst 6506, 6509 (core switch, Supervisor 2)	X
Cisco Catalyst 6506, 6509 (MSFC, Supervisor 2)	X
Cisco Catalyst 6506, 6509 (Supervisor 720)	X
Cisco Communication Media Module (CMM)	X
CiscoWorks Management Center for Cisco Security Agents	X
Cisco Security Agent	X
Cisco Unified Operations Manager	X
Cisco SCCP Unified IP Phones	X
Cisco SIP Unified IP Phones	X

## New Components and Features in Target Release Set

No new components were added to the Cisco Unified Communications System Release 6.1(1) release set.

## Components Not in Target Release Set

No components were removed from the Cisco Unified Communications System Release 6.1(1) release set in relation to the base release set.



### Note

For a list of recommended replacements (if any) for components that are no longer supported or sold, see the EOS and EOL website at: [http://www.cisco.com/en/US/products/prod\\_end\\_of\\_life.html](http://www.cisco.com/en/US/products/prod_end_of_life.html). For Cisco EOS and EOL policy, see the information at: [http://www.cisco.com/en/US/products/products\\_end-of-life\\_policy.html](http://www.cisco.com/en/US/products/products_end-of-life_policy.html).

## System Upgrade Paths

This section provides the general information required to migrate from a common starting point leading up to the latest Cisco Unified Communications System releases. System releases include the following types of releases:

- Major release—Marks the beginning of a major new release version. This release type typically is based on a major release of at least one of these components: Cisco Unified Call Manager, Cisco Unified Customer Voice Portal, Cisco Customer Response Solutions.
- Minor release—Adds features and fixes to an existing major release. This release type can consist of revisions to existing components and new versions of components.
- Maintenance release—Contains bug fixes for one or more of the components. This release type is based on an existing major or minor release.

## Upgrading from IPC Systems Test Release Sets

If you plan to upgrade from an IPC Systems Test release set to the Cisco Unified Communications System release set, be aware of the following possible upgrade paths.



### Note

You can access a complete listing of all the IPC Systems Test releases at:

[http://www.cisco.com/univercd/cc/td/doc/product/voice/ip\\_tele/gblink/ipcmatrix.htm](http://www.cisco.com/univercd/cc/td/doc/product/voice/ip_tele/gblink/ipcmatrix.htm)

- Major IPC System Test to Major IPC System Test. For example, System Test 3.0 to 4.0 (not indicated in graphic).
- Major IPC System Test to Minor IPC System Test. For example, System Test 4.0 to 4.1 (indicated by horizontal arrow in [Figure 4-1](#)).
- Minor IPC System Test to Minor IPC System Test. For example, System Test 4.1 to 4.2.
- Minor IPC Systems Test to Major Cisco Unified Communications System. For example, from System Test 4.1 to Unified Communications 5.0.
- Minor IPC Systems Test to Minor Cisco Unified Communications System. For example, from System Test 4.2 to Unified Communications 5.1(1).

Refer to [Figure 4-1](#) for a visual representation of the upgrade paths.



### Note

The horizontal arrows represent the upgrade paths within an individual release, The vertical arrows indicate the upgrade paths from one release to the next.

## Upgrading from Cisco Unified Communications System Release Sets

If you plan to upgrade from an Cisco Unified Communications System release set, be aware of the following possible upgrade paths.

- Major Cisco Unified Communications System to minor Cisco Unified Communications System. For example, Cisco Unified Communications System Release 6.0(1) to Release 6.1(1).
- Major Cisco Unified Communications System or minor Cisco Unified Communications System to Cisco Unified Communications System maintenance release. For example, Cisco Unified Communications System Release 5.0(1) to Release 5.0(2) and Release 5.1(1) to Release 5.1(2).
- Minor Cisco Unified Communications System to major Cisco Unified Communications System. For example, Cisco Unified Communications System Release 5.1(1) to Release 6.0(1).
- Cisco Unified Communications System maintenance release to major Cisco Unified Communications System. For example, Cisco Unified Communications System Release 5.0(2) to Release 6.0(1).

See [Figure 4-1](#) for a visual representation of some of the upgrade paths.

**Figure 4-1 Upgrade Paths for IPC Systems Test and Cisco Unified Communications System Releases**

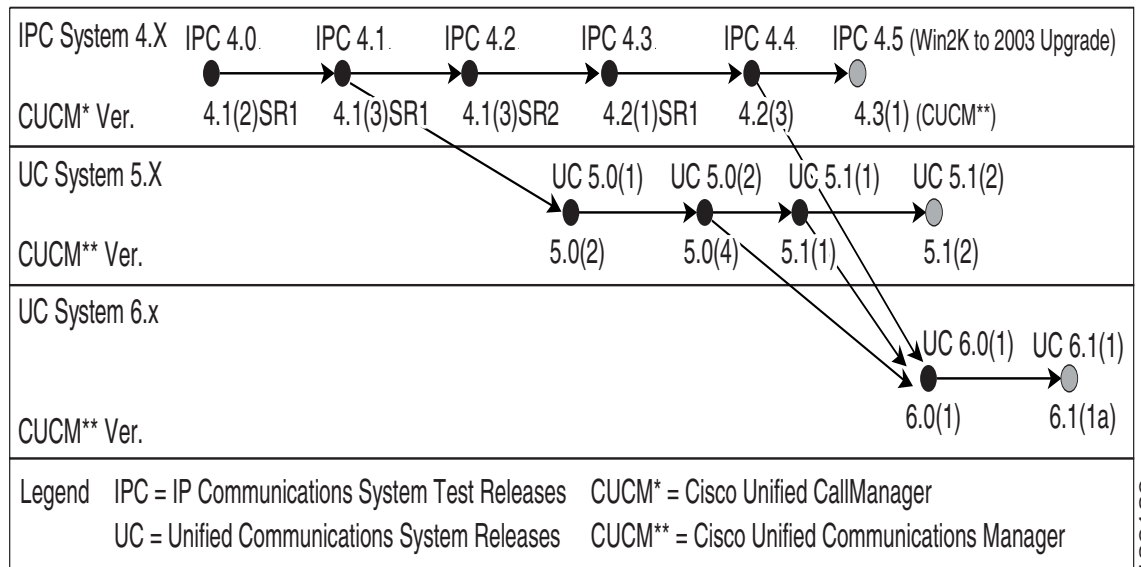

T86180

## Upgrade Paths to Cisco Unified Communications System Release 6.1(1)

[Figure 4-1](#) illustrates the upgrade path available for Cisco Unified Communications System Release 6.1(1) in contact center environments:

- Major release Cisco Unified Communications System Release 6.0(1) to minor Cisco Unified Communications System Release 6.1(1)

# System Upgrade Strategies

This section discusses the upgrade strategies for all components in the target release deployment scenarios. Details of individual components upgrades are not described unless additional information or clarification is required.

The following upgrade strategies are available for use when upgrading to the target release:

- Single-stage upgrade using existing hardware (*flash-cut*)—All components in the network start at the base release set and all components can be upgraded to the target release set within a single maintenance window.
- Single-stage upgrade using new hardware (either *flash-cut* or *shrink-and-grow*)—A parallel network should be built using new hardware and prestaged with configuration to support the existing production network.

All users can then be moved from the existing production network to the new network in one of two ways:

- In a single maintenance window using a flash-cut upgrade process
- In several maintenance windows using a shrink-and-grow upgrade process (where a single maintenance window is used to implement the new release versions on the new hardware, but multiple windows are used to migrate the users)



## Note

We recommend that you do not use backup and restore procedures to perform the prestaged configuration on the parallel network. In many applications, you are required to use the same hostname and IP address for the backup as well as the restore process. This can prevent you from creating a truly parallel network, as two systems cannot exist on the same network with identical hostnames and IP addresses.

The above upgrade strategies involving the single-stage upgrade approach are appropriate for small sites (fewer than 300 seats) with a smaller number of components in the network.

- Multistage system upgrade using existing hardware (hybrid system)—The components in individual sites can be upgraded from the base release set software to the target release set software in stages, during separate maintenance windows.

At the completion of each intermediate stage, the network within each site exists as a *hybrid system* with a mix of the following:

- Some components are operating on the base release set
- Other upgraded components are operating on the target release set



## Note

*Hybrid system* refers only to interproduct versions, not to intraproduct versions. For instance, all Unified Communications Manager servers in the same cluster, or all servers that are part of the same Unified ICM system, will remain at the same software version.

The multistage system upgrade approach is recommended for medium-to-large sites (ranging from 301 to 1,499 seats for medium and 1,500 to 4,999 seats for large) with a greater number of components in the network.

- Multisite migration (via hybrid network with release set interworking)—Components are upgraded from the base release set software to the target release set software on a site-by-site basis, during separate maintenance windows.



At the completion of each maintenance window, a *hybrid network* exists within the multiple sites with a mix of the following:

- Sites whose components are operating on the base release set
- Sites whose components are operating on the target release set
- Sites whose components are a hybrid system as described in [Multistage System Upgrade Using Existing Hardware \(Hybrid System\)](#)

This model assumes that sites may be upgraded independently. However, with the multisite migration strategy, you must account for distributed applications with shared components among sites. For example, if you have deployed a distributed Unified ICM system or a Unified Communications Manager cluster using Clustering over the WAN (CoW), then these sites must be upgraded concurrently.

Users can be moved in stages from the existing production network to the new network operating on the target release set software.

The multisite migration strategy is recommended for large multisite environments (more than 5,000 seats) with a large number of components in the network.

## Single-Stage Upgrade Using Existing Hardware

All components in the network start at the base release set and all components are upgraded to the target release set software within a single maintenance window. Because all components are upgraded within a single maintenance window, interoperability is not required between the base and target release sets.

The single-stage upgrade on existing hardware approach is typically not recommended for large customer sites and networks, because it has to be performed within a single maintenance window.

[Figure 4-2](#) shows an example of the single maintenance window that is involved in the single-stage upgrade on existing hardware approach.

**Figure 4-2** Single-Stage Upgrade Using Existing Hardware

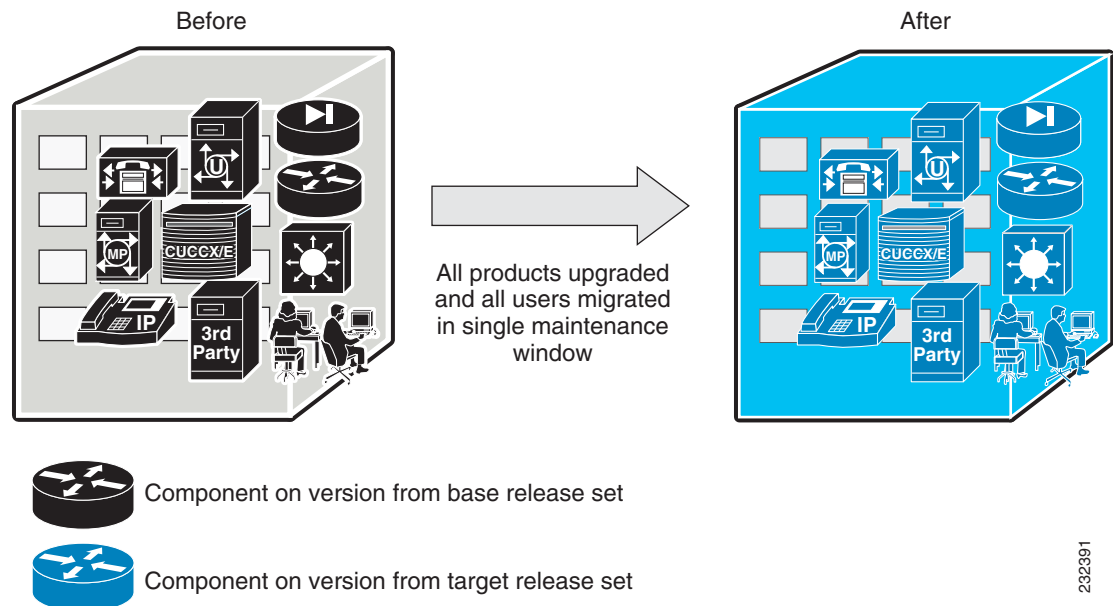

232391

## Single-Stage Upgrade Using New Hardware

A parallel Cisco Unified Communications System network should be built using new hardware and prestaged with configuration to support the existing production network. All users can be then moved from the existing production network to the new network operating with the target release set software either in a single maintenance window (using flash-cut) or in several maintenance windows (using shrink-and-grow).

The single-stage upgrade on new hardware approach is not recommended for large customer sites and networks for the following reasons:

- The upgrade cannot be performed within a single maintenance window.
- The expense of a complete new parallel network is significant.

Figure 4-3 shows an example of the maintenance windows that are involved in the single-stage upgrade on new hardware approach.

**Figure 4-3** Single-Stage Upgrade Using New Hardware

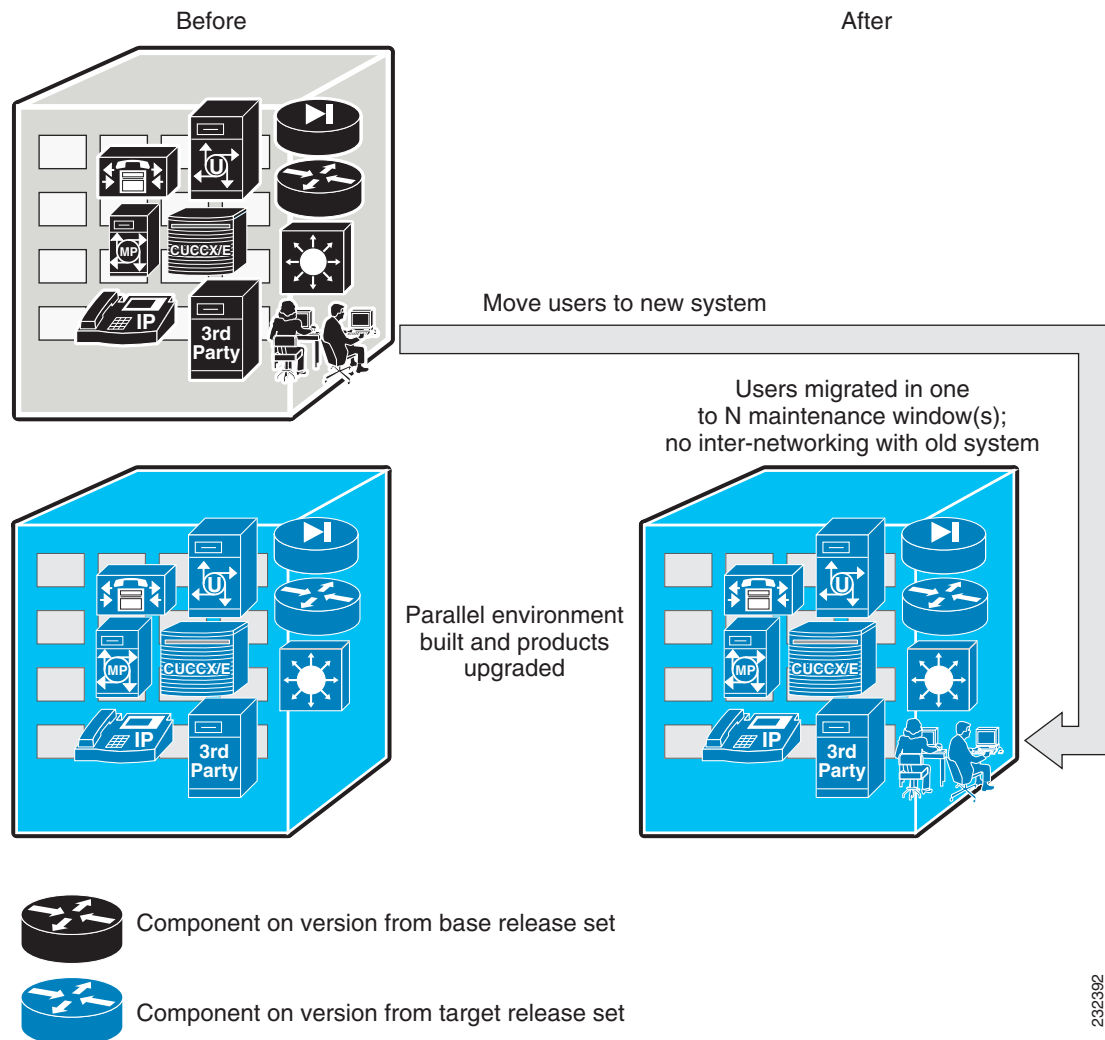

232392

## Multistage System Upgrade Using Existing Hardware (Hybrid System)

Individual components and/or sites can be upgraded in stages, from the base release set software to the target release set software, during separate maintenance windows. At the completion of each intermediate stage, the individual site exists as a *hybrid system* with a mix of the following:

- Some components operating on the base release set software
- Other upgraded components operating on the target release set software

The multistage system upgrade on existing hardware is the recommended approach for medium-to-large networks. In this case, individual components within a single site and/or individual sites in a multisite environment are progressively upgraded over the span of several days or weekends.

This type of staging is required because:

- Sufficient time may not be available (maintenance window) to take the system out of service for the complete upgrade of all the components involved.
- You must test existing functionality following the upgrade.
- You must test new functionality following the upgrade.

You can view a staged upgrade as a series of maintenance windows separated by intermaintenance window intervals. During each maintenance window, one or more components of the system or a subset of the components is upgraded.

Customers typically have a maintenance window during which service disruptions are likely to have minimal impact and affect only a limited number of users, for example, during the night or during a weekend.

Before the staged upgrade is completed, the whole network exists in a partially upgraded state where some components have been upgraded to the target release set software and the remaining components are operating with the base release set software.

Backward compatibility of the components is critical during the staged upgrade, so that target release set components are able to interoperate with the base release set components. If any component is not backward compatible, this can potentially result in prolonged periods of service outage spanning several maintenance windows (possibly several weeks).

Therefore, during multistage upgrades, it is mandatory to have interoperability between the base and target release set software versions. For more information about software and backward compatibility considerations, see [Chapter 5, “Preparing for Your System Upgrade.”](#)

Figure 4-4 shows an example of the maintenance windows that are involved in the multistage system upgrade on existing hardware approach.

**Figure 4-4 Multistage System Upgrade Using Existing Hardware (Hybrid System)**

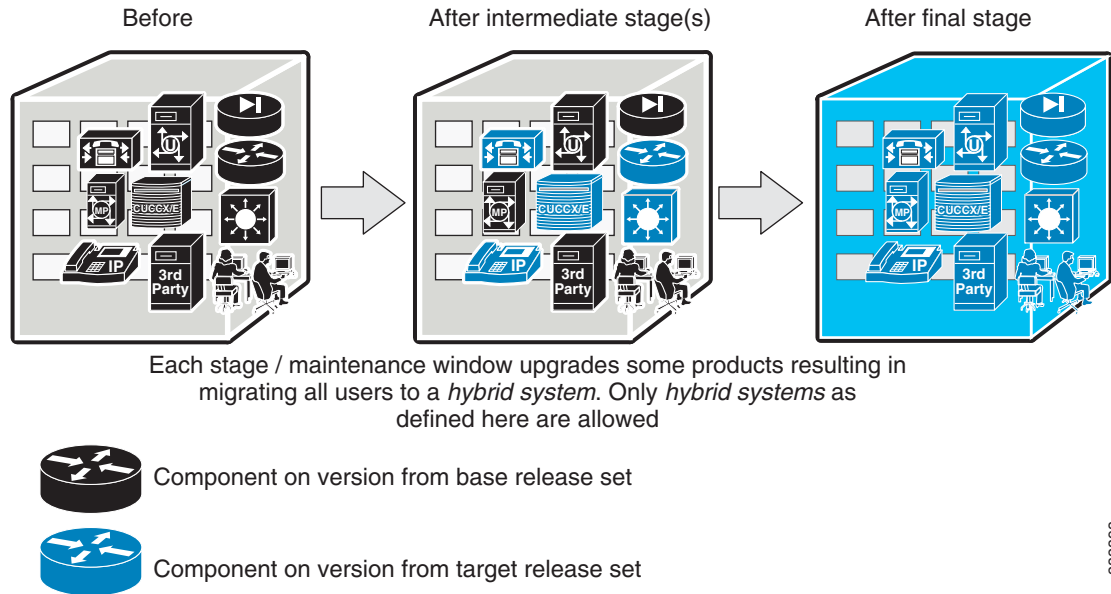

232393

## Multisite Migration (Hybrid Network)

Components are upgraded from the base release set to the target release set on a site-by-site basis during separate maintenance windows.

At the completion of each maintenance window, a *hybrid network* will exist across multiple sites. Within each site, either a single-stage or multistage system upgrade strategy can be used to upgrade that particular site's components from the base to the target release set.

Interworking can be expected among sites with *pure* base release set versions and sites with *pure* target release set versions as shown in Figure 4-5. However, interworking will not be possible between these *pure* sites and *hybrid system* sites. For more information about software and backward compatibility considerations, see Chapter 5, "Preparing for Your System Upgrade."



### Note

A component that is common to multiple sites, such as a shared Unified ICM system, may impact the interoperability itself, the order in which sites may be upgraded, or which sites must be upgraded concurrently.

Users can be moved in stages from the existing production network to the new network operating with the target release set software. The number of users on the existing base network will shrink while the number on the target network will grow correspondingly.

This migration process can span several weeks and, sometime months, if necessary. During this upgrade approach, it is essential that the two networks, existing and new, are able to communicate with each other.

Figure 4-5 shows an example of the maintenance windows that are involved in the multisite migration approach.

Figure 4-5 Multisite Migration

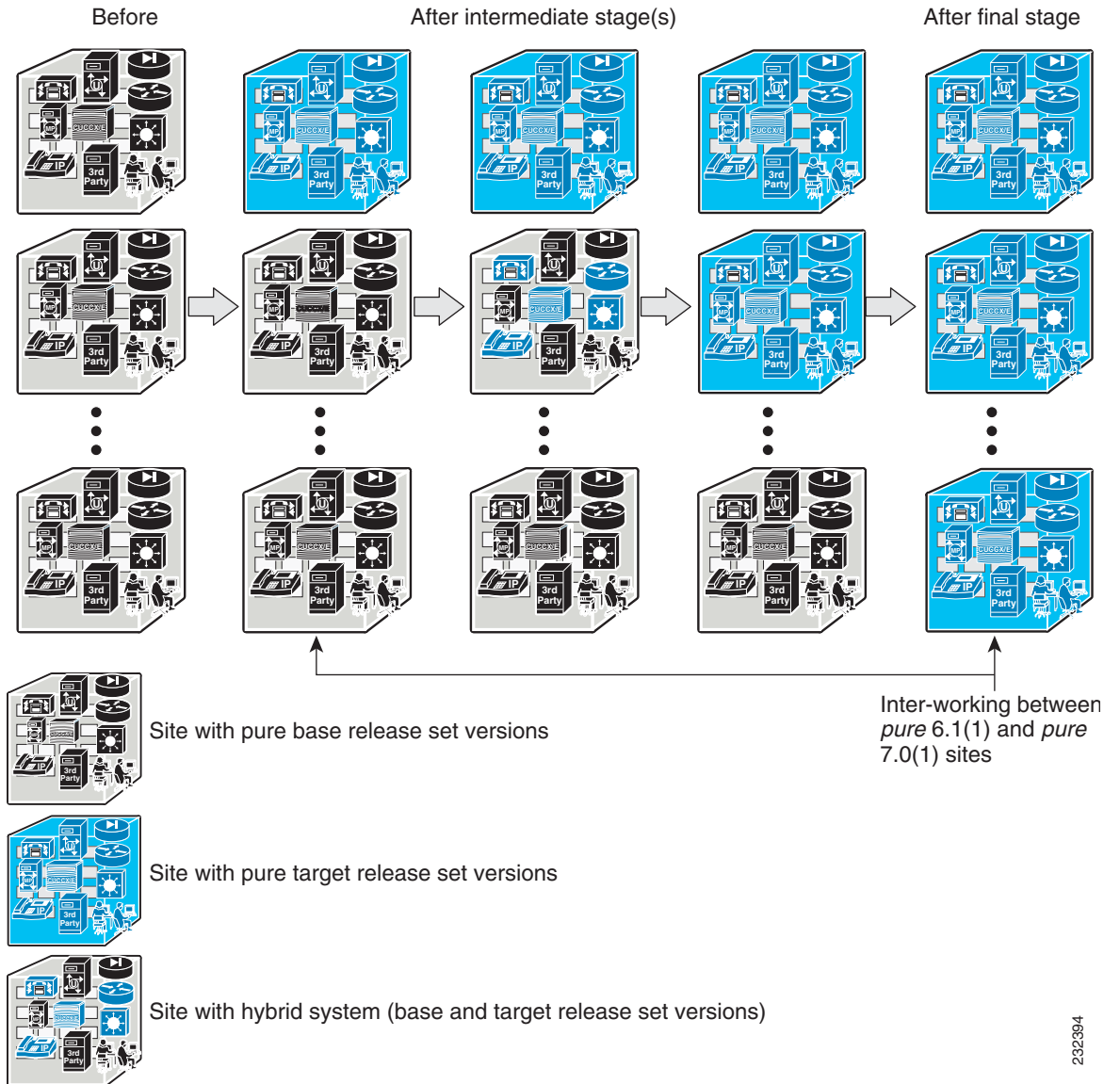

232394

Table 4-2 provides a summary of the preceding upgrade strategies.

**Table 4-2 Summary of Upgrade Strategies**

	<b>Single-Stage Upgrade</b>	<b>Multistage System Upgrade</b>	<b>Multisite Migration</b>
<b>Recommended for type of deployment</b>	<ul style="list-style-type: none"> <li>• Small single-site</li> <li>• Small multisite (fewer than 300 seats)</li> </ul>	<ul style="list-style-type: none"> <li>• Medium single-site</li> <li>• Medium multisite (301 to 1,499 seats)</li> <li>• Large single-site (1,500 to 4,999 seats)</li> </ul>	<ul style="list-style-type: none"> <li>• Large multisite (5,000 seats and more)</li> </ul>
<b>Maintenance Window</b>	1	Multiple	Multiple
<b>Interoperability between releases at component level</b>	Not Required	Required	Required
<b>Interoperability between releases at site level</b>	Not Required	Not Required for medium single-site and large single-site Required for medium multisite	Required
<b>User migration</b>	Complete in one stage	Partial until final stage	Partial until final stage
<b>Upgrade time period</b>	One time slot, for example, during a weekend maintenance window	Several days to weeks	Several weeks to months



## CHAPTER 5

# Preparing for Your System Upgrade

---

This topic discusses information to be aware of before the actual upgrade process such as the general upgrade approach for the different contact center components, upgrade release versions of components involved in the upgrade, and release version compatibility.

This topic contains the following sections:

- [System Upgrade Approach](#)
- [System Upgrade Dependencies](#)
- [Upgrade Release Versions](#)



### Note

---

Many of the contact center component names have changed as part of Cisco Unified Communications System releases. Only the latest product names are used in this document, even when referencing products from previous releases.

---

## System Upgrade Approach

The general approach is to upgrade each Cisco Unified Communications Manager (formerly known as Cisco Unified Communications Manager) cluster and its associated contact center components at one time, before upgrading the next cluster.

For each cluster, upgrade the components in the Cisco Unified Communications family of contact center components in the following order:

1. Infrastructure components, including core and access switches, routers, and security components. These components should be upgraded first to ensure that the infrastructure is able to support the services required by Cisco Unified Communications System components.
2. Contact center components
3. Application clients including Cisco Unified Contact Center Enterprise (Unified CCE) Agent and Supervisor Desktop clients, and others
4. Call processing components such as Unified Communications Manager clusters
5. Cisco voice gateways
6. Cisco gatekeepers
7. Application servers including Cisco Unified ICM Support Tool servers (Security applications are not included)

See [Chapter 6, “Performing Your System Upgrade”](#) for detailed information about the order in which the above components have to be upgraded.

The upgrade sequence of the contact center components should also be dictated by the following considerations:

- The criticality of the service that these components provide. For example, basic phone service is considered to be of greater importance than supplementary services or voice messaging services.
- Backward compatibility of the software releases of these components.

See [Upgrade Release Versions](#) for tables on each base release set, which indicates which components need to be upgraded before or after upgrading Unified Communications Manager, or if the upgrade order does not matter.

## System Upgrade Dependencies

Components within each release set should be compatible with each other and will interoperate correctly. For example, components in a specific base release set are compatible with each other and will interoperate, as also the components in the target release set.

The order of operations also needs to take into account the impact of backward compatibility or incompatibility as described later in this section, especially for multistage system and multisite migration upgrades, where each stage (or maintenance window) only upgrades some of the components in the release set.

However, as you upgrade individual components of the integrated system, the overall system may operate in a state of degraded service where one or more components have been upgraded to the next release level and may not interoperate with components that are still at the previous release level.

Components that are upgraded first should interoperate with other components that are still at the previous release level. For example, Unified Communications Manager is upgraded before the gateways. Therefore, Unified Communications Manager, which is now at the next release level, must interoperate with the gateways that have not been upgraded and are still at the previous release level. For additional compatibility information, see the release set software version tables in [Upgrade Release Versions](#).

## Cisco Unified Communications Manager Upgrade and Compatibility Considerations

Because Unified Communications Manager is upgraded early in the upgrade sequence, it has to be compatible with other components running Cisco Unified Communications software release versions.

### Upgrading from Cisco Unified Communications Manager 6.0(1) to Release 6.1(1a)

Be aware of the following constraints regarding Cisco Unified Communications Manager when upgrading from Cisco Unified Communications System Release 6.0(1) to Release 6.1(1):

- For Unified Communications Manager, you must perform all software installations and upgrades using the Software Upgrade Menu Options. Only software approved by Cisco Systems can be uploaded and processed by the system installer.
- Before you perform an upgrade, we recommend that you back up the Unified Communications Manager and CDR Analysis and Reporting (CAR) database to an external network directory using the Disaster Recovery Framework. This practice will prevent any loss of data if the upgrade fails.



- If Unified Communications Manager clusters are set up in a 1:1 redundancy model, downtime during upgrade can be kept to a minimum. You can do this by load-balancing device registrations across the first node (primary) and backup subsequent nodes (subscribers). This way if either the subsequent node server fails or is taken down for maintenance, only half of the devices will have to failover to the remaining subsequent nodes, but will ensure that all devices can remain in service.
- When upgrading Unified Communications Manager clusters, the first node should always be upgraded first. Before rebooting the first node after its upgrade, you can upgrade all the subsequent nodes simultaneously without rebooting them.

After all the nodes in the cluster are upgraded, make sure that you do the following in the listed order:

1. Reboot and switch versions to Unified Communications Manager 6.1(1a) on the first node and wait until the first node is initialized and fully operational.
2. Install the upgrade license and any other licenses that are required.
3. Reboot and switch versions to Unified Communications Manager 6.1(1a). Perform this procedure on the TFTP and Music-On-Hold (MoH) servers first.
4. Wait until the TFTP servers fully build their configuration files.
5. Reboot and switch versions to Unified Communications Manager 6.1(1a) on the backup and call processing subsequent nodes and wait until these servers are fully initialized.
6. Complete the upgrade by rebooting and switching versions to Unified Communications Manager 6.1(1a) on the remaining active call processing subsequent nodes in the cluster.



**Note** For further details about recommended upgrade procedures, see Chapter 8 of the *Cisco Unified Communications SRND based on Cisco Unified Communications Manager 6.x*:  
[http://www.cisco.com/en/US/products/sw/voicesw/ps556/products\\_implementation\\_design\\_guide\\_book09186a008085eb0d.html](http://www.cisco.com/en/US/products/sw/voicesw/ps556/products_implementation_design_guide_book09186a008085eb0d.html)

- When you upgrade the Unified Communications Manager servers, note that the Unified IP Phone software is also automatically upgraded to the version bundled with Unified Communications Manager.

## Cisco Unified IP Phone

When you upgrade your Unified Communications Manager servers, note that the Unified IP Phone firmware is also automatically upgraded to the version bundled with the Unified Communications Manager.

For more detailed information about SIP Unified IP Phones and the differences between features on the SCCP and SIP phones, see the documentation at:

- Cisco 7900 Series IP Phones Maintain and Operate Guides:  
[http://www.cisco.com/en/US/products/hw/phones/ps379/prod\\_maintenance\\_guides\\_list.html](http://www.cisco.com/en/US/products/hw/phones/ps379/prod_maintenance_guides_list.html)
- Cisco 7900 Series IP Phones End-User Guides:  
[http://www.cisco.com/en/US/products/hw/phones/ps379/products\\_user\\_guide\\_list.html](http://www.cisco.com/en/US/products/hw/phones/ps379/products_user_guide_list.html)
- “IP Telephony Endpoints” chapter in the *Cisco Unified Communications SRND based on Cisco Unified Communications Manager 6.x*:  
[http://www.cisco.com/en/US/products/sw/voicesw/ps556/products\\_implementation\\_design\\_guide\\_book09186a008085eb0d.html](http://www.cisco.com/en/US/products/sw/voicesw/ps556/products_implementation_design_guide_book09186a008085eb0d.html)

## Backward Compatibility Issues

In multistage system upgrade scenarios, you may have to consider additional issues such as backward compatibility across components.

A version of one component is backward compatible with a previous version of another component when service functionality and behavior are maintained between the two component versions. Backward compatibility between two components or applications may limit the order of upgrade of the components and cause service outage during upgrades.

If two components are upgraded during separate maintenance windows, as in the multistage system or multisite migration upgrade scenarios, the whole system exists in a partially upgraded state in the interval between the two maintenance windows.

The service capability during the period between maintenance windows depends on backward compatibility between the two components as discussed in this section. If the two components are not backward compatible, then service outages occur in the interval between the two maintenance windows.

Some backward compatibility situations described in [Backward Compatibility Scenarios](#) may occur during the upgrade process. For more information, see the component compatibility matrices listed in [Chapter 6, “Related Documentation”](#).

## Backward Compatibility Scenarios

### Both New Versions Are Backward Compatible

Both new versions of the two components are backward compatible with the previous version of the other component,

In this case, there is no restriction in the order of upgrades relating to backward compatibility. Either component may be upgraded first and be able to interoperate with the other component as shown in [Figure 5-1](#).

You can perform the upgrade for these components across multiple maintenance windows. This type of upgrade is described in the multistage system and multisite migration upgrade approaches in [Chapter 4, “Planning Your System Upgrade.”](#)

**Figure 5-1 Both New Release Versions Are Backward Compatible**

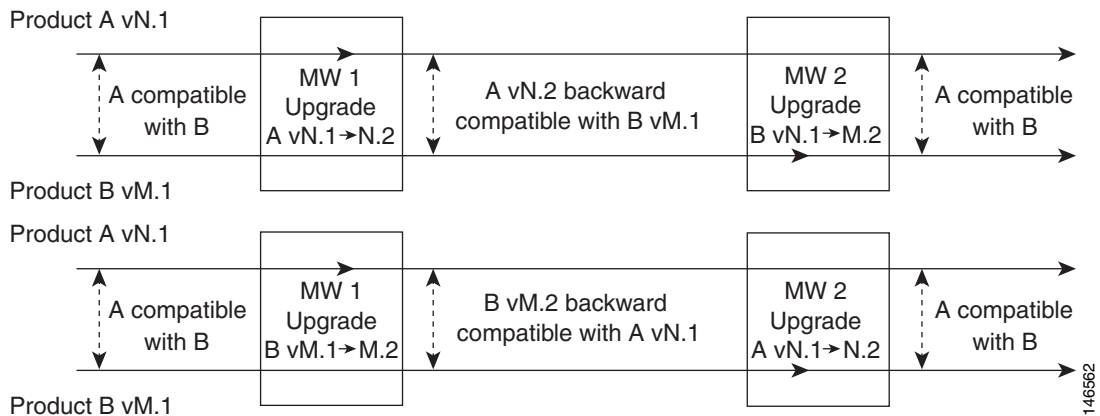

### Only One New Version is Backward Compatible

Only one of the new versions is backward compatible with the previous version of the other component.

In this case, the component that is backward compatible should be upgraded first to avoid a service outage during the upgrade as shown in Figure 5-2.

You should perform the upgrade for these components across two separate maintenance windows. This type of upgrade is described in the Multistage System and Multisite Migration upgrade approaches in Chapter 4, “Planning Your System Upgrade.”

**Figure 5-2 One New Release Version Is Backward Compatible**

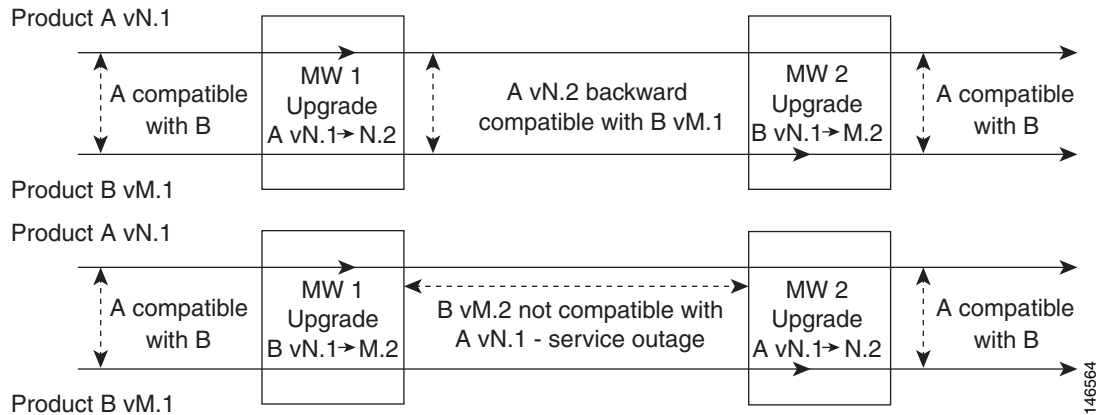

### Neither New Version is Backward Compatible

Neither of the new versions is backward compatible with the previous version of the other component.

A service outage exists from the time the first product is upgraded until the second component has completed its upgrade as shown in Figure 5-3.

Because neither component is backward compatible with the other, both components have to be upgraded in the same maintenance window to avoid service outage. This upgrade is described in the Single-Stage upgrade approach in Chapter 5, “Preparing for Your System Upgrade.”

**Figure 5-3 Neither New Release Version is Backward Compatible**

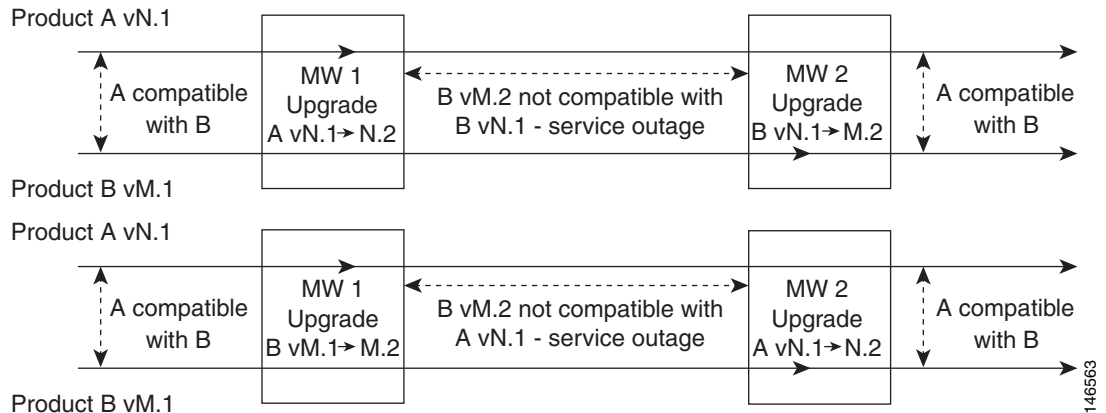

# Upgrade Release Versions

The tables in this section list the component release versions of the base and target release sets and provide additional compatibility and upgrade sequence information in relation to Unified Communications Manager 6.1(1a).

The tables have the following elements:

- Column 1—Contact center components involved in the upgrade process.
- Column 2—Release versions of contact center components in the base release set.
- Column 3—Release versions of contact center components in the target release set.
- Column 4—Whether the contact center component in the base release set is compatible with the version of Unified Communications Manager in the target release.
- Column 5—Upgrade order for the contact center component in relation to Unified Communications Manager, where “Any” means that the component can be upgraded either before or after upgrading Unified Communications Manager.

## Release 6.0(1) and Release 6.1(1) Software Release Sets

Table 5-1 lists the software versions for the contact center components in the Cisco Unified Communications System Release 6.0(1) and Release 6.1(1) release sets.

**Table 5-1** Contact Center Components in IP Communications System Test Release 6.0(1) and Cisco Unified Communications System Release 6.1(1) Release Sets

Component	Release 6.0(1) Release Set	Release 6.1(1) Release Set	Compatible with Unified Communications Manager 6.1(1a)?	Upgrade Order (in relation to Unified Communications Manager)
Cisco Unified Communications Manager	6.0(1)	6.1(1a) <sup>1</sup>	Yes <sup>2</sup>	—
Cisco Unified Presence	6.0(1)	6.0(2) <sup>1</sup>	Yes	Any
Cisco Unified Intelligent Contact Management	7.2(1)	7.2(2)	Yes	Before
Cisco Unified Intelligent Contact Management Operating System	Win2003 SP2/ Win2003 R2 SP2	Win2003 SP2/ Win2003 R2 SP2	—	—
Cisco Unified ICM Support Tools (Server and Agent)	2.1	2.2(1)	Yes	Upgraded with Unified ICM
Cisco Customer Response Solutions (Unified IP IVR)	5.0(1) SR1	5.0(2)	Yes	Any
Cisco Customer Response Solutions (Unified IP IVR) Operating System	2003.1.1 SR5	2003.1.2a SR5	—	—
Cisco Unified Customer Voice Portal	4.0(2)	4.0(2) <sup>3</sup>	Yes	Any
Cisco Unified Customer Voice Portal Operating System	Win2003 SP2/ Win2003 R2 SP2	Win2003 SP2/ Win2003 R2 SP2	—	—

**Table 5-1** Contact Center Components in IP Communications System Test Release 6.0(1) and Cisco Unified Communications System Release 6.1(1) Release Sets (continued)

Component	Release 6.0(1) Release Set	Release 6.1(1) Release Set	Compatible with Unified Communications Manager 6.1(1a)?	Upgrade Order (in relation to Unified Communications Manager)
Cisco Unity Connection and Unity TSP	2.0 & 8.1(3)	2.0 & 8.1(3)	Yes	Upgrade Unity TSP in same maintenance window as Unified Communications Manager  Upgrade Unity Connection after Unified Communications Manager
Cisco IP Communicator	2.1(1)	2.1(1)	Yes	Any
Cisco Unified IP Phones (Both SCCP and SIP Phones are included)	Bundled with Unified Communications Manager	Bundled with Unified Communications Manager	—	—
Cisco Unified Operations Manager	2.0.1	2.0.2	Yes	Any
Cisco Catalyst 6500 Series Firewall Service Module (FWSM)	3.1(5)	3.2(2)	—	Any
Cisco Adaptive Security Appliance (ASA) 5540 Services	8.0	8.0(3)	—	Any
Cisco Security Agent Management Center for Cisco Security Agents	5.0.0.216	5.0.0.216	—	—
Cisco Security Agent for Unified Communications Manager	Bundled with Unified Communications Manager	Bundled with Unified Communications Manager	—	—
Cisco Security Agent for Customer Response Solutions	5.0.0.216 /3.0.4	5.0.0.217 /3.0.6	—	—
Cisco Security Agent for Unified Intelligent Contact Management	5.0.0.210 /3.0.1	5.0.0.210 /3.0.1	—	—
Cisco Security Agent for Unified Customer Voice Portal	5.2.0.203 /2.2.1	5.2.0.203 /2.2.1	—	—
Cisco 3725, 3745 (Unified CVP VXML, voice/data, H.323, SIP, and MGCP gateways)	12.4(15)T	12.4(15)T3	Yes	Any
Cisco 3825, 3845 (Unified CVP VXML, voice/data, H.323, SIP, and MGCP gateways)	12.4(15)T	12.4(15)T3	Yes	Any

**Table 5-1 Contact Center Components in IP Communications System Test Release 6.0(1) and Cisco Unified Communications System Release 6.1(1) Release Sets (continued)**

Component	Release 6.0(1) Release Set	Release 6.1(1) Release Set	Compatible with Unified Communications Manager 6.1(1a)?	Upgrade Order (in relation to Unified Communications Manager)
Cisco AS5400HPX, AS5400XM (Unified CVP VXML, voice, H.323, and PSTN gateways)	12.4(15)T	12.4(15)T3	Yes	Any
Cisco AS5850 (PSTN and voice gateway)	12.4(15)T	12.4(15)T3	Yes	Any
Cisco 3745 (gatekeeper)	12.4(15)T	12.4(15)T3	Yes	Any
RSVP Agent (on 37xx and 38xx platforms)	12.4(15)T	12.4(15)T3	Yes	Any
Cisco 7206 (core/WAN router)	12.4(15)T	12.4(15)T3	Yes	Any
Cisco 871 router	12.3(8)Y12	12.3(8)Y12	Yes	Any
Cisco Catalyst 3750 (access switch)	12.2(25)SEC2	12.2(25)SEE2	Yes	Any
Cisco Catalyst 6506, 6509 (core switch, supervisor 2)	CatOS 8.5(8)	CatOS 8.5(8)	Yes	Any
Cisco Catalyst 6506, 6509 (MSFC, supervisor 2)	12.2(18)SXF8	12.2(18)SXF8	Yes	Any
Cisco Catalyst 6506, 6509 (Supervisor 720)	12.2(18)SXF8	12.2(18)SXF8	Yes	Any
Cisco CSS 11501 Content Services Switch	WebNs 7.50.3.3	WebNs 7.50.3.3	Yes	After
Cisco Catalyst Communications Media Module (CMM)	12.4(15)T	12.4(15)T3	Yes	Any
Cisco Aironet Access Point 1240AG	12.3-8.JA2	12.3-8.JA2	Yes	Any
McAfee Antivirus	Enterprise 8.0.0 Patch Version: 11	Enterprise 8.0.0 Patch Version: 11	Yes	Any

1. For important information on servers on which the component software is running, see *System Release Notes for Contact Center: Cisco Unified Communications System Release 6.1(1)* at: <http://www.cisco.com/univercd/cc/td/doc/systems/unified/uc611/relnotes/rnipc611.htm>.
2. Only applies to multisite distributed and only for H.323 Intercluster Trunk (features supported by ICT).
3. For important information on engineering specials associated with Unified CVP Release 4.0(2), see *System Release Notes for Contact Center: Cisco Unified Communications System Release 6.1(1)* at: <http://www.cisco.com/univercd/cc/td/doc/systems/unified/uc611/relnotes/rnipc611.htm>.



# CHAPTER 6

## Performing Your System Upgrade

---

This topic discusses in more detail the upgrade sequence for all the contact center components configured in specific deployment models for Cisco Unified Communications System Release 6.1(1).

Upgrade procedures for individual components are not described in this document, because they are available in individual component upgrade documents. See the [Related Documentation](#) section at the end of this topic for the appropriate upgrade documents and their URLs.

This topic contains the following sections:

- [Deployment Models](#)
- [Upgrading Components](#)
- [Related Documentation](#)



### Note

---

Many of the contact center component names have changed as part of Cisco Unified Communications System releases. Only the latest product names are used in this document, even when referencing products from previous releases.

---

## Deployment Models

Upgrade procedures in this document are specifically tailored for each of the deployment models in the contact center test environment, because each site includes different components.

Detailed information about these contact center deployment models at the different sites is available at: [http://www.cisco.com/cisco/web/docs/iam/unified/ipcc611/Review\\_Tested\\_Deployment\\_Models.html](http://www.cisco.com/cisco/web/docs/iam/unified/ipcc611/Review_Tested_Deployment_Models.html)

Listed in this section are the various deployment models tested in the Cisco Unified Communications contact center test environment:

- [Single-Site Model](#)
- [Multisite Centralized Model](#)
- [Multisite Distributed Model](#)
- [Clustering over the WAN \(CoW\) Model](#)

Compare these deployments to your specific deployment to best understand the upgrade process that is applicable in your environment. The following section provides the general upgrade sequence for the various contact center components in the different deployment models.

After you determine the general upgrade sequence, depending on the base release set in your network, use one of the upgrade strategies discussed in [Upgrading Components](#) to upgrade your components. More detailed upgrade procedures for contact center components and Cisco Unified Communications Manager (formerly known as Cisco Unified CallManager) clusters are discussed in [Upgrading Contact Center Test Beds](#).

## Single-Site Model

In the single-site model, upgrade the components in the following order:

1. Infrastructure components including core and access switches, routers, and security components
2. Contact center components:
  - Cisco Unified ICM system (CallRouter, Logger, Peripheral Gateway)
  - Real-time Administration Workstation (at least one)
  - CTI OS and Cisco Agent Desktop (CAD) servers
  - Cisco Unified Outbound Dialer
  - CTI OS Agent and Supervisor Desktop
  - Cisco Agent Desktop (CAD) and Cisco Supervisor Desktop (CSD)
  - VoIP Monitor
3. Cisco Unified Communications Manager (Cisco Unified IP Phones are upgraded at the same time)
4. Cisco Unified Customer Voice Portal Voice Browser/Application Server/HTTP Media Server
5. CRS (Cisco Unified IP IVR)
6. Cisco Unified Operations Manager
7. Voice and data gateways



---

**Note** In a Unified CVP implementation, upgrade the voice and data gateways in the same maintenance window as Unified CVP.

---

8. Cisco applications coresident on MCS servers (such as Cisco Security Agent, JTAPI software)
9. Third-party on-board agents on MCS servers (such as antivirus, backup agent, management agent (SNMP))



---

**Note** For Unified Communications Manager Release 6.1(1a), third-party on-board agents must be installed on a separate MCS server.

---

10. Cisco and third-party adjunct applications or endpoints on other servers



## Multisite Centralized Model

In the multisite centralized model, upgrade the components in the following order:

1. Infrastructure components including core and access switches, routers, and security components
2. Contact center components:
  - Cisco Unified ICM system (CallRouter, Logger, Peripheral Gateway)
  - Real-time Administration Workstation (at least one)
  - Cisco Unified System Contact Center Gateway (Unified SCCG), and Cisco Unified Contact Center Gateway Enterprise (Unified CCGE)
  - CTI OS and Cisco Agent Desktop (CAD) servers
  - Cisco Unified Outbound Dialer
  - Unity Connection
  - CTI OS Agent and Supervisor Desktop
  - Cisco Agent Desktop (CAD) and Cisco Supervisor Desktop (CSD)
  - VoIP Monitor
3. Cisco Unified Communications Manager servers (Cisco Unified IP Phones are upgraded at the same time)
4. Cisco Unified Customer Voice Portal Voice Browser/Application Server/HTTP Media Server
5. CRS (Cisco Unified IP IVR)
6. Cisco Unified Operations Manager
7. Voice and data gateways



---

**Note** In a Unified CVP implementation, upgrade the voice and data gateways in the same maintenance window as Unified CVP.

---

8. Cisco applications coresident on MCS servers (such as Cisco Security Agents, JTAPI software)
9. Third-party on-board agents on MCS servers (such as antivirus, backup agent, management agent (SNMP))



---

**Note** For Unified Communications Manager Release 6.1(1a), third-party on-board agents must be installed on a separate MCS server.

---

10. Cisco and third-party adjunct applications or endpoints on other servers

## Multisite Distributed Model

In the multisite distributed model, upgrade the components in the following order:

1. Infrastructure components including core and access switches, routers, and security components
2. Contact center components:
  - Cisco Unified ICM system (CallRouter, Logger, Peripheral Gateway)

- Real-time Administration Workstation (at least one)
  - Cisco Unified System Contact Center Gateway (Unified SCCG), and Cisco Unified Contact Center Gateway Enterprise (Unified CCGE)
  - CTI OS and Cisco Agent Desktop (CAD) servers
  - Cisco Unified Outbound Dialer
  - Unity Connection
  - CTI OS Agent and Supervisor Desktop
  - Cisco Agent Desktop (CAD) and Cisco Supervisor Desktop (CSD)
  - VoIP Monitor
3. Cisco Unified Communications Manager servers (Cisco Unified IP Phones are upgraded at the same time)
  4. Cisco Unified Customer Voice Portal Voice Browser/Application Server/HTTP Media Server
  5. CRS (Cisco Unified IP IVR)
  6. Cisco Unified Operations Manager
  7. Voice and data gateways



---

**Note** In a Unified CVP implementation, upgrade the voice and data gateways in the same maintenance window as Unified CVP.

---

8. Cisco applications coresident on MCS servers (such as Cisco Security Agent, JTAPI software)
9. Third-party on-board agents on MCS servers (such as antivirus, backup agent, management agent (SNMP))



---

**Note** For Unified Communications Manager Release 6.1(1a), third-party on-board agents must be installed on a separate MCS server.

---

10. Cisco and third-party adjunct applications or endpoints on other servers

## Clustering over the WAN (CoW) Model

In the Clustering over the WAN (CoW) model, upgrade the components in the following order:

1. Infrastructure components including core and access switches, routers, and security components
2. Contact center components:
  - Cisco Unified ICM system (CallRouter, Logger, Peripheral Gateway)
  - Real-time Administration Workstation (at least one)
  - Cisco Unified System Contact Center Gateway (Unified SCCG), and Cisco Unified Contact Center Gateway Enterprise (Unified CCGE)
  - CTI OS and Cisco Agent Desktop (CAD) servers
  - Cisco Unified Outbound Dialer
  - Unity Connection

- CTI OS Agent and Supervisor Desktop
  - Cisco Agent Desktop (CAD) and Cisco Supervisor Desktop (CSD)
  - VoIP Monitor
3. Cisco Unified Communications Manager servers (Cisco Unified IP Phones are upgraded at the same time)
  4. Cisco Unified Customer Voice Portal Voice Browser/Application Server/HTTP Media Server
  5. CRS (Cisco Unified IP IVR)
  6. Cisco Unified Operations Manager
  7. Voice and data gateways



---

**Note** In a Unified CVP implementation, upgrade the voice and data gateways in the same maintenance window as Unified CVP.

---

8. Cisco applications coresident on MCS servers (such as Cisco Security Agent, JTAPI software)
9. Third-party on-board agents on MCS servers (such as antivirus, backup agent, management agent (SNMP))



---

**Note** For Unified Communications Manager Release 6.1(1a), third-party on-board agents must be installed on a separate MCS server.

---

10. Cisco and third-party adjunct applications or endpoints on other servers

## Upgrading Components

Once you have reviewed the general upgrade sequence for your specific deployment model, perform your upgrades based on the following upgrade strategies:

- **Single-Stage Upgrade**—Recommended for small single-site and multisite installations.
- **Multistage System Upgrade**—Recommended for medium and large single-site and medium multisite installations.
- **Multisite Migration**—To upgrade large, multisite contact center installations to the Cisco Unified Communications release set using the multisite migration upgrade strategy, you can use either the single-stage or multistage system upgrade procedures listed in this section.

See [Chapter 4, “Planning Your System Upgrade”](#) for detailed information about the above upgrade strategies and [Chapter 5, “Preparing for Your System Upgrade”](#) for the software release versions of the components involved in the upgrade. For more information about the number of seats in these various types of sites, see Table 4-2 in [Chapter 4, “Planning Your System Upgrade”](#).

The upgrade paths available for upgrading contact center components are defined in System Upgrade Paths in [Chapter 4, “Planning Your System Upgrade”](#).

See Table 6-3 in [Related Documentation](#) for a list of URLs to component-specific release notes and installation and upgrade documents. When performing the upgrade of each component, see the product-specific upgrade document for detailed information.

## Single-Stage Upgrade

The single-stage upgrade process is recommended for small single-site and multisite installations and can be performed in a single maintenance window. This enables you to upgrade all the components in a brief period of time with no loss of functionality.

See [Chapter 5, “Preparing for Your System Upgrade”](#) for the software release versions of the components involved in the upgrade. Based on your environment and the base release set deployed in your network, upgrade the components in the order listed in [Table 6-1](#).

**Table 6-1** Single-Stage Upgrade Order for Contact Center Components

Upgrade Order	Components Being Upgraded
1	Core switch
2	Access switch
3	Real Time AW/HDS/Webview
4	Cisco Unified ICM Rogger/Progger
5	Peripheral Gateway, Unified SCCG, Unified CCGE
6	CTI OS Server
7	CAD Server
8	Cisco Unified Outbound Dialer
9	Cisco Unity Connection
10	CTI OS Agent & Supervisor Desktop
11	CAD Agent & Supervisor Desktop
12	Cisco Unified Communications Manager cluster (Cisco Unified IP Phones and are upgraded with the cluster)
13	Cisco Unified Customer Voice Portal Voice Browser/Application Server/HTTP Media Server
14	CRS (Cisco Unified IP IVR)
15	Cisco Unified Operations Manager
16	Voice and data gateways <sup>1</sup>
17	Cisco applications coresident on MCS servers
18	Third-party on-board agents on MCS servers <sup>2</sup>
19	Cisco and third-party applications on other servers

1. In a Unified CVP implementation, upgrade the voice and data gateways in the same maintenance window as Unified CVP.
2. For Unified Communications Manager Release 6.1(1a), third-party on-board agents must be installed on a separate MCS server.

## Multistage System Upgrade

A multistage system upgrade is the recommended approach for medium and large single-site and medium multisite installations. In this upgrade process, components are grouped together for upgrading in several stages or maintenance windows. Within each maintenance window, there is a recommended order for upgrading each component.

The grouping of the components into the stages may vary depending on the size of the networks being upgraded. For smaller networks, several separate maintenance windows may be collapsed into a single maintenance window. Additional stages may be necessary for larger sites.

After each maintenance window, we recommend that you verify that the operation of all basic and critical call types remains unaffected before you initiate the next upgrade stage listed in the table. We also recommend that you maintain a list to track the components that have been upgraded and the ones yet to be upgraded.

See [Chapter 5, “Preparing for Your System Upgrade”](#) for the software release versions of the components involved in the upgrade. Based on your environment and the base release set deployed in your network, upgrade the components in the stages and in the sequence within each stage as listed in [Table 6-2](#).

**Table 6-2** *Multistage System Upgrade Order for Contact Center Components*

Stage	Upgrade Order for Contact Center Components within Stages
1	<ol style="list-style-type: none"> <li>1. Core Switch</li> <li>2. Access Switch</li> </ol>
2	<ol style="list-style-type: none"> <li>1. Real Time AW/HDS/Webview</li> <li>2. Cisco Unified ICM Rogger</li> </ol>
3	<ol style="list-style-type: none"> <li>1. Peripheral Gateway, Unified SCCG, Unified CCGE</li> <li>2. CTI OS Server</li> <li>3. CAD Server</li> <li>4. Cisco Unified Outbound Dialer</li> <li>5. Cisco Unity Connection</li> </ol>
4	<ol style="list-style-type: none"> <li>1. CTI OS Agent/Supervisor Desktop</li> <li>2. CAD Agent/Supervisor Desktop</li> </ol>
5	<ol style="list-style-type: none"> <li>1. Cisco Unified Communications Manager cluster (Cisco Unified IP Phones are upgraded along with cluster)</li> </ol>
6	<ol style="list-style-type: none"> <li>1. Cisco Unified Customer Voice Portal Voice Browser/Application Server/HTTP Media Server</li> </ol>
7	<ol style="list-style-type: none"> <li>1. CRS (Unified IP IVR)</li> </ol>
8	<ol style="list-style-type: none"> <li>1. Cisco Unified Operations Manager</li> </ol>
9	<ol style="list-style-type: none"> <li>1. IOS Gateways (MGCP)</li> <li>2. IOS Gateways (H.323)</li> <li>3. Cisco Unified Customer Voice Portal VXML Gateways</li> <li>4. Cisco Gatekeepers</li> </ol>
10	<ol style="list-style-type: none"> <li>1. Cisco applications coresident on MCS servers</li> </ol>
11	<ol style="list-style-type: none"> <li>1. Third-party on-board agents on MCS servers</li> </ol>
12	<ol style="list-style-type: none"> <li>1. Cisco and third-party applications on other servers</li> </ol>

## Upgrading Contact Center Test Beds

The contact center test sites are set up as three separate test beds:

- Test Bed 1—Cisco Unified Communications Manager Call Flows— Unified IP IVR test bed with Unified Communications Manager Post-Routed call flows. Use normal upgrade procedures based on the single-stage or multistage upgrade approaches discussed in [Chapter 4, “Planning Your System Upgrade”](#).
- Test Bed 2—Parent and Child Call Flows—The parent and child model has been deployed in this test bed and calls are routed from parent to child systems and child to child systems.

Upgrade all the parent systems at the data centers *before* upgrading the child systems at the data centers and remote sites. The child systems have to be compatible with the parent systems that are running the new software versions.

For detailed information about the deployment options and limitations for the Unified Communications Manager Post-Routed and Parent and Child call flows, see the Cisco Unified Contact Center Gateway feature at:

<http://www.cisco.com/univercd/cc/td/doc/systems/unified/uc611/starmipc/ch2model.htm>

- Test Bed 3—Cisco Unified CVP Post-Routed Call Flows—Cisco Unified Customer Voice Portal (Unified CVP) test bed with Unified CVP Post-Routed call flows. Use normal upgrade procedures based on the single-stage or multistage upgrade approaches discussed in [Chapter 4, “Planning Your System Upgrade”](#).



### Note

To verify the interoperability between clusters running different release set versions, some of the Unified Communications Manager clusters in Test Bed 3 have not been upgraded.

## Related Documentation

The following sections list compatibility guides and installation documentation for Cisco Unified Communications System components:

- [Compatibility Guides](#)
- [Component Release Notes and Installation and Upgrade Documents](#)

For information about support for legacy products and third-party product interoperability with Cisco Unified Communications contact center products, see the Cisco Interoperability Portal at:

[www.cisco.com/go/interoperability](http://www.cisco.com/go/interoperability)

## Compatibility Guides

For compatibility and interoperability information about Unified Communications Manager, Unified Contact Center Enterprise, CRS and other Cisco Unified Communications contact center products, see the following sites:

- Cisco Unified Communications Compatibility Tool:  
<http://tools.cisco.com/ITDIT/vtgsc>
- *IPCC Enterprise Software Compatibility Guide*:  
[http://www.cisco.com/application/pdf/en/us/guest/products/ps1844/c1609/ccmigration\\_09186a008031a0a7.pdf](http://www.cisco.com/application/pdf/en/us/guest/products/ps1844/c1609/ccmigration_09186a008031a0a7.pdf)

- *Cisco Response Solutions (CRS) Software and Hardware Compatibility Guide:*  
[http://www.cisco.com/univercd/cc/td/doc/product/voice/sw\\_ap\\_to/crscomtx.pdf](http://www.cisco.com/univercd/cc/td/doc/product/voice/sw_ap_to/crscomtx.pdf)
- Cisco Computer Telephony Integration Option: CTI Compatibility Matrix:  
[http://www.cisco.com/en/US/products/sw/custcosw/ps14/prod\\_technical\\_reference\\_list.html](http://www.cisco.com/en/US/products/sw/custcosw/ps14/prod_technical_reference_list.html)
- Cisco Unified Communications System Release Summary Matrix for Contact Center:  
<http://www.cisco.com/univercd/cc/td/doc/systems/unified/ccmtrix.htm>
- IP Communications System Test Release Matrix:  
[http://www.cisco.com/univercd/cc/td/doc/product/voice/ip\\_tele/gblink/ipcmtrix.htm](http://www.cisco.com/univercd/cc/td/doc/product/voice/ip_tele/gblink/ipcmtrix.htm)

## Component Release Notes and Installation and Upgrade Documents

Table 6-3 provides a listing of contact center components and URLs for related component release notes and installation and upgrade documents. These URLs link to webpages that list various release versions of these documents. Review the appropriate documents based on the release versions of the components in your base and target release sets.

**Table 6-3** *Component-Specific Release Notes and Installation and Upgrade Documents*

Components	Release Notes	Installation and Upgrade Documents
Cisco Unified Communications Manager	<a href="http://www.cisco.com/en/US/products/sw/voicew/ps556/prod_release_notes_list.html">http://www.cisco.com/en/US/products/sw/voicew/ps556/prod_release_notes_list.html</a>	<a href="http://www.cisco.com/en/US/products/sw/voicew/ps556/prod_installation_guides_list.html">http://www.cisco.com/en/US/products/sw/voicew/ps556/prod_installation_guides_list.html</a>
Cisco Unified Intelligent Contact Management	<a href="http://www.cisco.com/en/US/products/sw/custcosw/ps1001/prod_release_notes_list.html">http://www.cisco.com/en/US/products/sw/custcosw/ps1001/prod_release_notes_list.html</a>	<a href="http://www.cisco.com/en/US/products/sw/custcosw/ps1001/prod_installation_guides_list.html">http://www.cisco.com/en/US/products/sw/custcosw/ps1001/prod_installation_guides_list.html</a>
Cisco Unified Contact Center Enterprise	<a href="http://www.cisco.com/en/US/products/sw/custcosw/ps1844/prod_release_notes_list.html">http://www.cisco.com/en/US/products/sw/custcosw/ps1844/prod_release_notes_list.html</a>	<a href="http://www.cisco.com/en/US/products/sw/custcosw/ps1844/prod_installation_guides_list.html">http://www.cisco.com/en/US/products/sw/custcosw/ps1844/prod_installation_guides_list.html</a>
CRS (Cisco Unified IP IVR)	<a href="http://www.cisco.com/en/US/products/sw/custcosw/ps1846/prod_release_notes_list.html">http://www.cisco.com/en/US/products/sw/custcosw/ps1846/prod_release_notes_list.html</a>	<a href="http://www.cisco.com/en/US/products/sw/custcosw/ps1846/prod_installation_guides_list.html">http://www.cisco.com/en/US/products/sw/custcosw/ps1846/prod_installation_guides_list.html</a>
Cisco Customer Voice Portal	<a href="http://www.cisco.com/en/US/products/sw/custcosw/ps1006/prod_release_notes_list.html">http://www.cisco.com/en/US/products/sw/custcosw/ps1006/prod_release_notes_list.html</a>	<a href="http://www.cisco.com/en/US/products/sw/custcosw/ps1006/prod_installation_guides_list.html">http://www.cisco.com/en/US/products/sw/custcosw/ps1006/prod_installation_guides_list.html</a>
Cisco Unified Outbound Dialer	<a href="http://www.cisco.com/en/US/products/sw/custcosw/ps1001/prod_release_notes_list.html">http://www.cisco.com/en/US/products/sw/custcosw/ps1001/prod_release_notes_list.html</a>	<a href="http://www.cisco.com/en/US/products/sw/custcosw/ps524/prod_installation_guides_list.html">http://www.cisco.com/en/US/products/sw/custcosw/ps524/prod_installation_guides_list.html</a>
Cisco Telephony Integration Object Server (CTI OS)	<a href="http://www.cisco.com/en/US/products/sw/custcosw/ps14/prod_release_notes_list.html">http://www.cisco.com/en/US/products/sw/custcosw/ps14/prod_release_notes_list.html</a>	<a href="http://www.cisco.com/en/US/products/sw/custcosw/ps14/prod_installation_guides_list.html">http://www.cisco.com/en/US/products/sw/custcosw/ps14/prod_installation_guides_list.html</a>
Cisco Agent Desktop (CAD)	<a href="http://www.cisco.com/en/US/products/sw/custcosw/ps427/prod_release_notes_list.html">http://www.cisco.com/en/US/products/sw/custcosw/ps427/prod_release_notes_list.html</a>	<a href="http://www.cisco.com/en/US/products/sw/custcosw/ps427/prod_installation_guides_list.html">http://www.cisco.com/en/US/products/sw/custcosw/ps427/prod_installation_guides_list.html</a>
Cisco Unity Connection	<a href="http://www.cisco.com/en/US/products/ps6509/prod_release_notes_list.html">http://www.cisco.com/en/US/products/ps6509/prod_release_notes_list.html</a>	<a href="http://www.cisco.com/en/US/products/ps6509/prod_installation_guides_list.html">http://www.cisco.com/en/US/products/ps6509/prod_installation_guides_list.html</a>

**Table 6-3** Component-Specific Release Notes and Installation and Upgrade Documents (continued)

Components	Release Notes	Installation and Upgrade Documents
Cisco IP Communicator	<a href="http://www.cisco.com/en/US/products/sw/voicesw/ps5475/prod_release_notes_list.html">http://www.cisco.com/en/US/products/sw/voicesw/ps5475/prod_release_notes_list.html</a>	—
Cisco Unified Operations Manager	<a href="http://www.cisco.com/en/US/products/ps6535/prod_release_notes_list.html">http://www.cisco.com/en/US/products/ps6535/prod_release_notes_list.html</a>	<a href="http://www.cisco.com/en/US/products/ps6535/prod_installation_guides_list.html">http://www.cisco.com/en/US/products/ps6535/prod_installation_guides_list.html</a>
Cisco Series 800 Routers	<a href="http://www.cisco.com/en/US/products/hw/routers/ps380/prod_release_notes_list.html">http://www.cisco.com/en/US/products/hw/routers/ps380/prod_release_notes_list.html</a>	<a href="http://www.cisco.com/en/US/products/hw/routers/ps380/prod_installation_guides_list.html">http://www.cisco.com/en/US/products/hw/routers/ps380/prod_installation_guides_list.html</a>
Cisco Series 7200 Routers	<a href="http://www.cisco.com/en/US/products/hw/routers/ps341/prod_release_notes_list.html">http://www.cisco.com/en/US/products/hw/routers/ps341/prod_release_notes_list.html</a>	<a href="http://www.cisco.com/en/US/products/hw/routers/ps341/prod_installation_guides_list.html">http://www.cisco.com/en/US/products/hw/routers/ps341/prod_installation_guides_list.html</a>
Cisco Catalyst 3600 Series MultiService Platforms	—	<a href="http://www.cisco.com/en/US/products/hw/routers/ps274/prod_installation_guides_list.html">http://www.cisco.com/en/US/products/hw/routers/ps274/prod_installation_guides_list.html</a>
Cisco AS5400 Series Universal Gateways	<a href="http://www.cisco.com/en/US/products/hw/univgate/ps505/prod_release_notes_list.html">http://www.cisco.com/en/US/products/hw/univgate/ps505/prod_release_notes_list.html</a>	<a href="http://www.cisco.com/en/US/products/hw/univgate/ps505/prod_installation_guides_list.html">http://www.cisco.com/en/US/products/hw/univgate/ps505/prod_installation_guides_list.html</a>
Cisco AS5850 Series Universal Gateways	—	<a href="http://www.cisco.com/en/US/products/hw/univgate/ps509/prod_installation_guides_list.html">http://www.cisco.com/en/US/products/hw/univgate/ps509/prod_installation_guides_list.html</a>
Cisco 3700 Series Voice Gateways/Gatekeepers	<a href="http://www.cisco.com/en/US/products/hw/routers/ps282/prod_release_notes_list.html">http://www.cisco.com/en/US/products/hw/routers/ps282/prod_release_notes_list.html</a>	<a href="http://www.cisco.com/en/US/products/hw/routers/ps282/prod_installation_guides_list.html">http://www.cisco.com/en/US/products/hw/routers/ps282/prod_installation_guides_list.html</a>
Cisco 3800 Series Voice Gateways	<a href="http://www.cisco.com/en/US/products/ps5855/prod_release_notes_list.html">http://www.cisco.com/en/US/products/ps5855/prod_release_notes_list.html</a>	<a href="http://www.cisco.com/en/US/products/ps5855/prod_installation_guides_list.html">http://www.cisco.com/en/US/products/ps5855/prod_installation_guides_list.html</a>
Cisco Catalyst 3550 Series Access Switches	<a href="http://www.cisco.com/en/US/products/hw/switches/ps646/prod_release_notes_list.html">http://www.cisco.com/en/US/products/hw/switches/ps646/prod_release_notes_list.html</a>	<a href="http://www.cisco.com/en/US/products/hw/switches/ps646/prod_installation_guides_list.html">http://www.cisco.com/en/US/products/hw/switches/ps646/prod_installation_guides_list.html</a>
Cisco Catalyst 6500 Series Switches	<a href="http://www.cisco.com/en/US/products/hw/switches/ps708/prod_release_notes_list.html">http://www.cisco.com/en/US/products/hw/switches/ps708/prod_release_notes_list.html</a>	<a href="http://www.cisco.com/en/US/products/hw/switches/ps708/prod_installation_guides_list.html">http://www.cisco.com/en/US/products/hw/switches/ps708/prod_installation_guides_list.html</a>
Cisco Unified IP Phone 7900 Series	<a href="http://www.cisco.com/en/US/products/hw/phones/ps379/prod_release_notes_list.html">http://www.cisco.com/en/US/products/hw/phones/ps379/prod_release_notes_list.html</a>	<a href="http://www.cisco.com/en/US/products/hw/switches/ps646/prod_installation_guides_list.html">http://www.cisco.com/en/US/products/hw/switches/ps646/prod_installation_guides_list.html</a>
Cisco IOS Software Release 12.4 T	<a href="http://www.cisco.com/en/US/products/ps6441/prod_release_notes_list.html">http://www.cisco.com/en/US/products/ps6441/prod_release_notes_list.html</a>	—





## INDEX

---

### A

#### applications

- agent desktop [5, 6, 8](#)
- coresident [2, 4, 2, 3, 4, 5](#)
- third-party [2, 4, 2, 3, 4, 5](#)
- third-party offboard [2](#)

---

### B

#### backward compatibility

- components [3, 2, 11, 2, 4, 5](#)
- installation sequence [3](#)
- scenarios [4, 5](#)
- upgrade sequence [2](#)

---

### C

#### call flow

- Cisco Unified Communications Manager Post-Routed [8](#)
- Cisco Unified CVP Post-Routed [8](#)
- parent and child [8](#)

#### call types

- basic and critical [7](#)

#### Cisco Unified Communications Manager

- call processing components [4](#)
- upgrade considerations [2](#)

#### Cisco Unified Communications System

- overview [1](#)

#### compatibility

- backward [3, 2, 11, 2, 4, 5](#)
- components [1, 2, 3, 4, 9, 6, 10, 11, 1, 2, 8](#)

guides and matrices [9, 10, 8](#)

software [2](#)

#### components

agent desktop applications [5, 6, 8](#)

application clients [6, 1](#)

application servers [3, 1](#)

backward compatibility [3, 2, 11, 2, 4, 5](#)

call processing [4, 3, 2, 4, 6, 8, 1](#)

call routing and agent management [4, 6, 8](#)

Cisco Unified Communications System 6.0(1) release set [6](#)

Cisco Unified Communications System 6.1(1) release set [6](#)

compatibility [1, 2, 3, 4, 9, 6, 10, 11, 1, 2, 8](#)

contact center [7, 1, 3, 4, 6, 8, 1, 5](#)

directory and network services [2, 4, 6, 7](#)

distributed system [9](#)

firewall and security [5](#)

gateways and gatekeepers [5, 3, 4, 6, 8, 1](#)

infrastructure [5, 2, 3, 5, 6, 7, 1](#)

installation order [1, 6, 7](#)

interoperability [1, 2, 3, 4, 9, 6, 10, 2, 11, 2, 8](#)

interworking [12](#)

IP telephony [1](#)

media resources [2, 4, 6, 8](#)

messaging [2, 4, 6, 8](#)

network management [8, 3, 4, 7, 8](#)

parent and child [5](#)

queuing and self-service [4, 6, 8](#)

release set definition [3, 2](#)

security [6, 7](#)

shared [3, 9](#)

SIP Proxy server [6](#)

upgrade order [1, 6, 7](#)

wireless [5, 6, 7](#)

#### contact center

components [7, 1, 3, 1, 3, 4, 6, 8, 1, 5](#)

components overview [4, 5](#)

installation overview [4, 5](#)

products [7, 1, 3, 4, 6, 8, 1, 5](#)

release sets [3, 6](#)

test bed with Cisco Unified CVP [8](#)

test bed with Cisco Unified IP IVR [8](#)

test bed with parent and child systems [8](#)

upgrade paths [7](#)

#### CRS

Cisco Unified IP IVR [2, 3, 4, 5](#)

## D

#### deployment models

Cisco Unified Contact Center Enterprise multisite centralized model [3](#)

Cisco Unified Contact Center Enterprise multisite distributed model [5, 3](#)

Cisco Unified Contact Center Enterprise single-site model [2](#)

Clustering over the WAN model [5, 4](#)

component installation order [1](#)

component upgrade order [1](#)

installation process [1](#)

parent and child [5](#)

topologies [3](#)

upgrade process [1](#)

#### deployment types

greenfield [2, 3](#)

installation [3](#)

installed base (brownfield) [3](#)

legacy [2, 3](#)

## H

#### hardware

equipment check [3](#)

installation [2](#)

requirements [3](#)

supported [3](#)

upgrade [2](#)

#### installation

before you begin [1](#)

Cisco Unified Contact Center Enterprise multisite centralized model [3](#)

Cisco Unified Contact Center Enterprise multisite distributed model [5](#)

Cisco Unified Contact Center Enterprise single-site model [2](#)

Clustering over the WAN model [5](#)

components [4, 5, 1, 6](#)

components grouping [7](#)

coresident applications [2, 4](#)

deployment models [1](#)

deployment types [3](#)

for large multiple sites [6](#)

for medium-to-large sites [6, 7](#)

for small sites [6](#)

general approach [3](#)

general sequence [3](#)

greenfield deployment [3, 8, 9](#)

hardware [2](#)

high-level tasks [4](#)

legacy deployment [3, 8, 9](#)

multisite phased [9, 6](#)

multistage [6, 7](#)

new network [3, 8](#)

order for components [1, 6, 7](#)

overview [4](#)

performing for systems [1](#)

planning for systems [1](#)

postimplementation phases [9](#)

- postinstallation phases [9](#)
- postinstallation tasks [4,9](#)
- preimplementation phases [1](#)
- preinstallation phases [1](#)
- preinstallation tasks [4,1](#)
- preparing for systems [1](#)
- process [4](#)
- single-stage [6](#)
- standalone components [2](#)
- strategy [8](#)
- system dependencies [6](#)
- system-level components [2](#)
- third-party applications [2,4](#)
- third-party offboard applications [2](#)
- installation strategy
  - for large multiple sites [9,6](#)
  - for medium-to-large sites [8,9,6,7](#)
  - for small sites [8,6](#)
  - multisite migration [9](#)
  - multistage on new hardware [9](#)
  - new network [8](#)
  - single-stage on new hardware [8](#)
  - types of [8](#)
- installation window
  - multiple [9](#)
  - single [8,9](#)
- installed base
  - upgrade [3](#)
- interoperability
  - between releases at component level [14](#)
  - between releases at site level [14](#)
  - legacy products [2,3,4](#)
  - legacy systems [2,3,4](#)
  - system components [1,2,3,4,9,6,10,2,8](#)
- interworking
  - components [12](#)
  - release set [8](#)
- IP telephony
  - components [1](#)

- products [1](#)

---

## M

- maintenance window
  - multiple [8,10,11,6](#)
  - single [8,9,10](#)
- migration
  - from installed base [3](#)
  - from legacy base [3](#)

---

## P

- parent and child
  - call flow [8](#)
  - components [5](#)
- products
  - contact center [7,1,3,4,6,8,1,5](#)
  - IP telephony [1](#)

---

## R

- release set
  - 6.0(1) components [6](#)
  - 6.1(1) components [4,6](#)
  - base release [3](#)
  - Cisco Unified Communications System Release 6.0(1) [3](#)
  - Cisco Unified Communications System Release 6.1(1) [3](#)
  - contact center deployments [3](#)
  - definition [3,2](#)
  - for installation [4](#)
  - for upgrade [3](#)
  - greenfield deployment [3](#)
  - installed base deployment [3](#)
  - interworking [8](#)
  - legacy deployment [3](#)
  - major to major upgrade [6](#)

- major to minor upgrade [6](#)
- minor to minor upgrade [6](#)
- overview [3](#)
- summary matrix [3](#)
- system test to system release [6](#)
- target release [3](#)

---

## S

### service

- impact on [6, 11, 2, 5](#)
- outage [4, 5](#)

### software

- client [6](#)
- compatibility [2](#)
- release sets [3, 4, 3](#)
- system and applications [6](#)

### software versions

- 6.0(1) components [6](#)
- 6.1(1) components [4, 6](#)
- matrix [3, 4, 6](#)

### system

- degraded service [6, 2](#)
- involved in upgrade [3](#)
- service criticality [3, 2](#)
- service disruptions [11](#)
- service outage [4, 5](#)
- upgrade dependencies [2](#)
- validation [4](#)
- verification [4](#)

### system releases

- maintenance release [6](#)
- major release [6](#)
- minor release [6](#)
- summary matrix [3, 9, 10, 8](#)

---

## T

### test bed

- Cisco Unified CVP call flows [8](#)
- Cisco Unified IP IVR call flows [8](#)
- parent and child call flows [8](#)
- upgrade [8](#)

---

## U

### Unified IP Phones

- upgrade considerations [3](#)

### upgrade

- backward compatibility [3](#)
- Cisco Unified Communications Manager considerations [2](#)
- Cisco Unified Contact Center Enterprise multisite centralized model [3](#)
- Cisco Unified Contact Center Enterprise multisite distributed model [3](#)
- Cisco Unified Contact Center Enterprise single-site model [2](#)
- Clustering over the WAN model [4](#)
- components [1, 5](#)
- components grouping [7](#)
- concurrent [9](#)
- coresident applications [2, 3, 4, 5](#)
- deployment models [1](#)
- flash-cut [8, 9](#)
- for large multiple sites [5](#)
- for medium-to-large sites [5, 6](#)
- for small sites [5](#)
- general approach [1](#)
- general sequence [1](#)
- high-level tasks [3](#)
- installed base [3](#)
- inter-sites [12](#)
- intra-site [11](#)
- maintenance releases [6](#)
- major releases [6](#)

- minor releases [6](#)
- multisite [8, 2, 4, 5](#)
- multistage [8, 11, 2, 4, 5, 6](#)
- order for components [1, 6, 7](#)
- partial (hybrid network) [9, 12](#)
- partial (hybrid system) [8, 11, 4](#)
- performing for systems [1](#)
- planning for systems [1](#)
- preparing for systems [1](#)
- process [3, 1](#)
- recommended paths [6](#)
- roadmap [3](#)
- shrink-and-grow [8, 10](#)
- single-site [9, 10](#)
- single-stage [8, 5](#)
- standalone components [2](#)
- strategy [3, 8](#)
- summary of strategies [14](#)
- supported paths [6](#)
- system dependencies [2](#)
- system-level components [2](#)
- test beds [8](#)
- third-party applications [2, 3, 4, 5](#)
- third-party offboard applications [2](#)
- time period [14](#)
- to hybrid network [9, 12](#)
- to hybrid system [8, 11, 4](#)
- Unified IP Phones considerations [3](#)
- upgrade considerations
  - Cisco Unified Communications Manager [2](#)
  - Unified IP Phones [3](#)
- upgrade paths
  - for components [7](#)
- upgrade strategy
  - for large multiple sites [9, 5](#)
  - for medium-to-large sites [8, 5, 6](#)
  - for small sites [8, 5](#)
  - multisite migration [8](#)
  - multistage on existing hardware [8, 11](#)
  - single-stage on existing hardware [8, 9](#)
  - single-stage on new hardware [8, 10](#)
  - summary [14](#)
  - types of [8](#)

